

Operating Dimensions

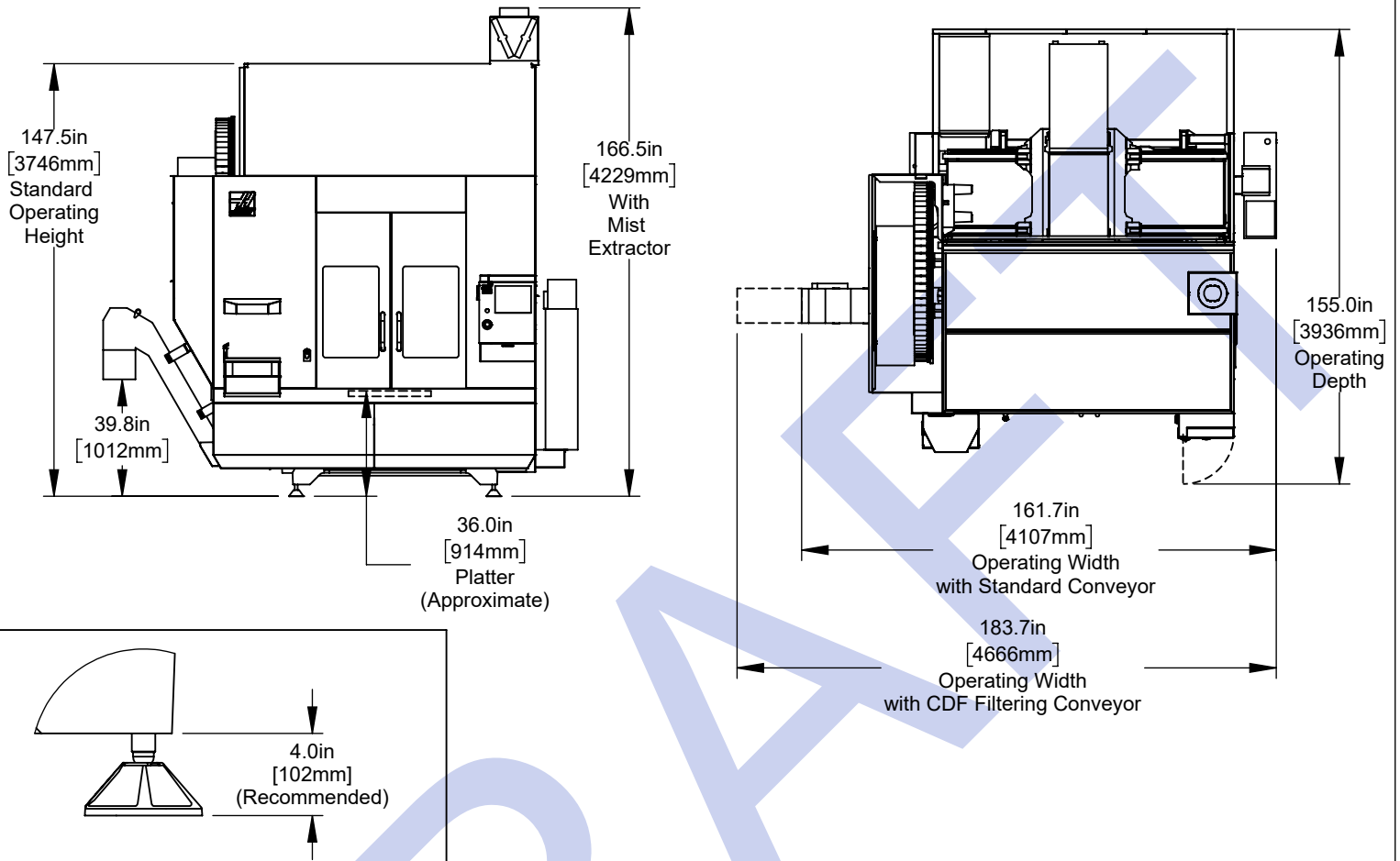

Shipping Dimensions

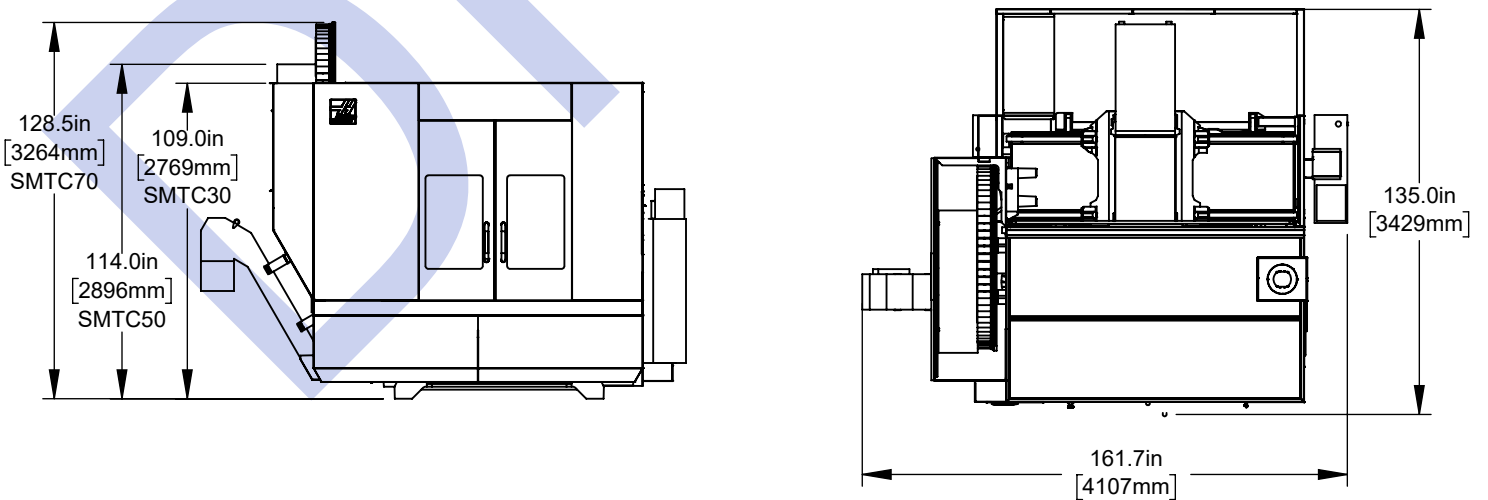

Air & Power

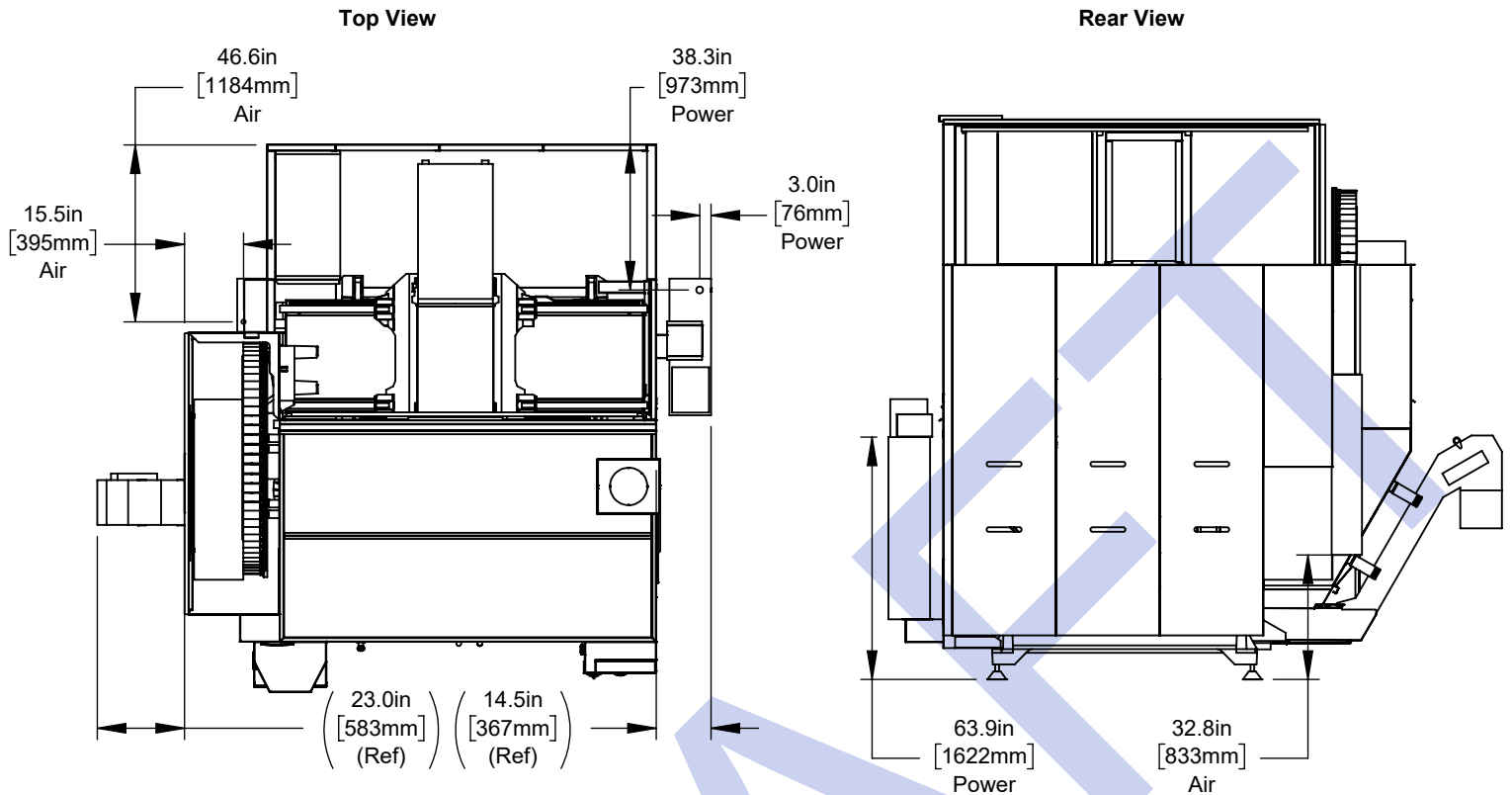

**Note** - Machine must be placed on one continuous concrete slab. Slab should extend 12in [305mm] beyond anchor holes in all directions

Anchor Pattern

**Anchor Hole Detail**

Ø.625in [16mm]  
▽ 3.5in [90mm]

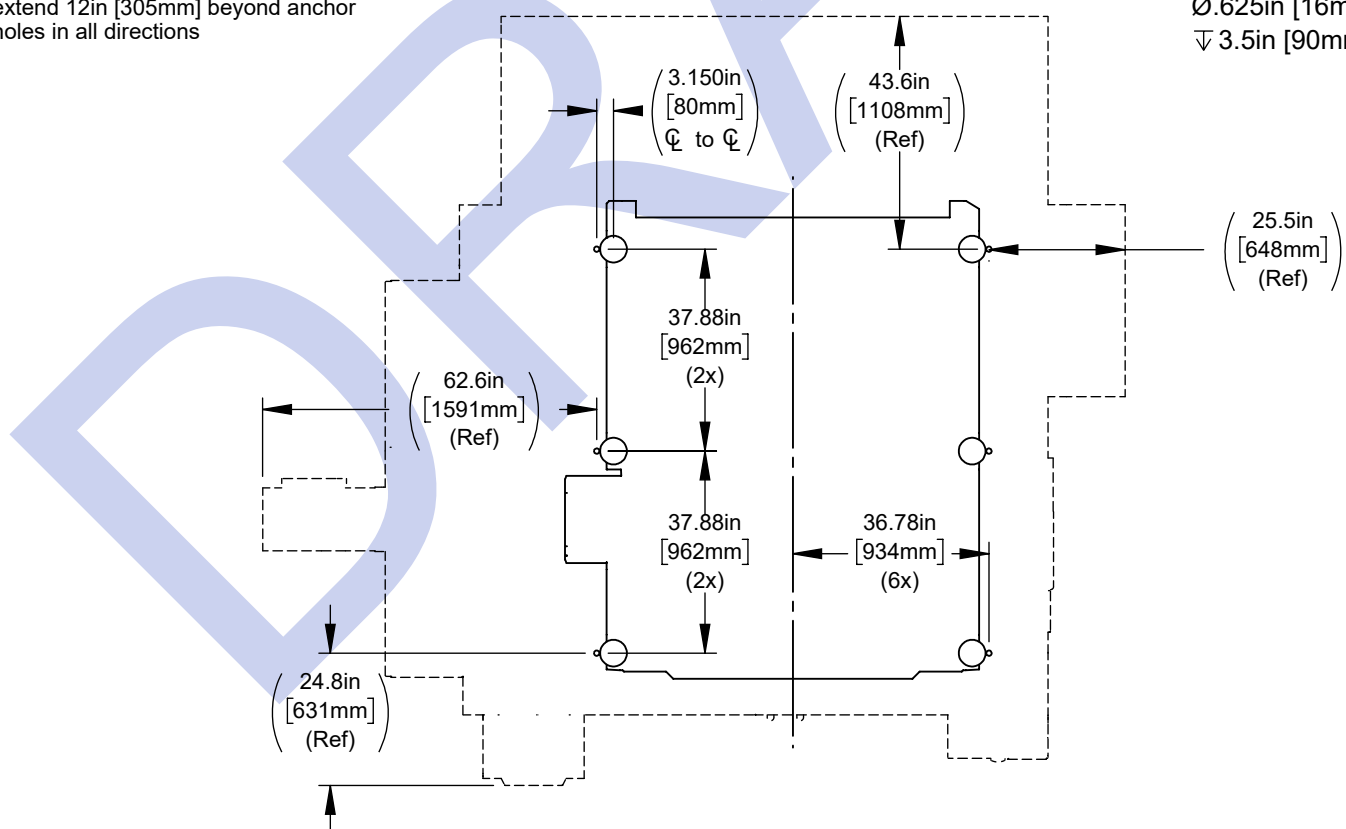

Height Breakdown

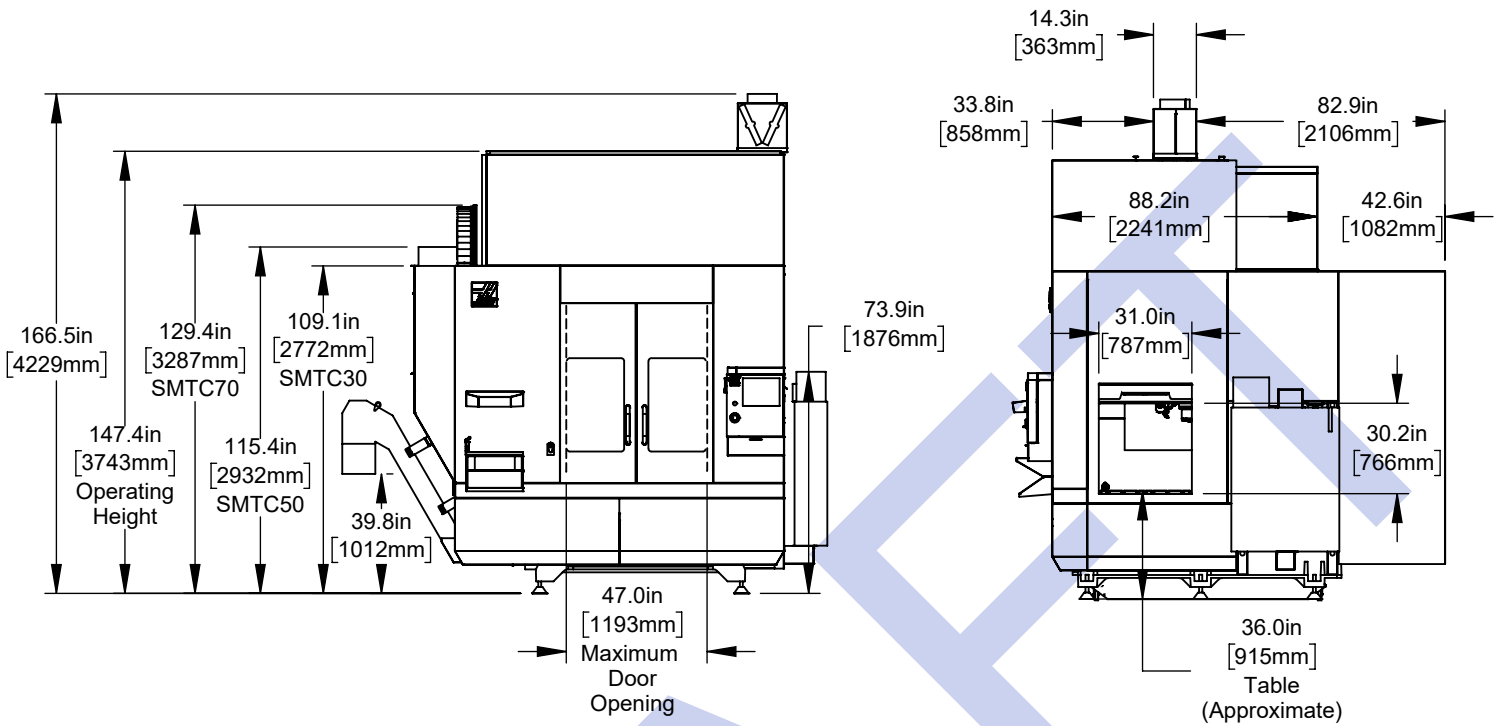

Width Breakdown

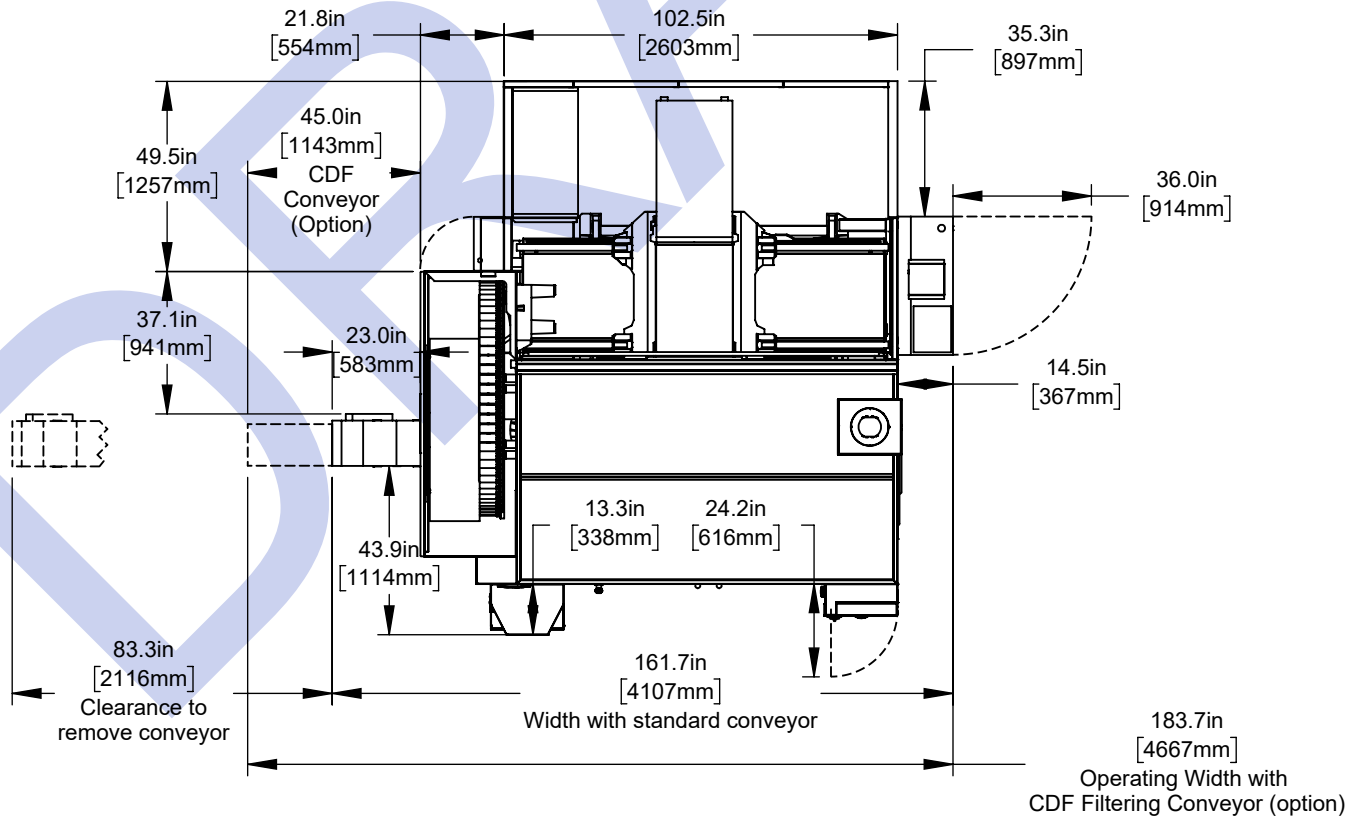

**Standard Table**

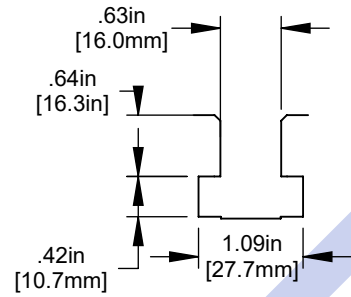
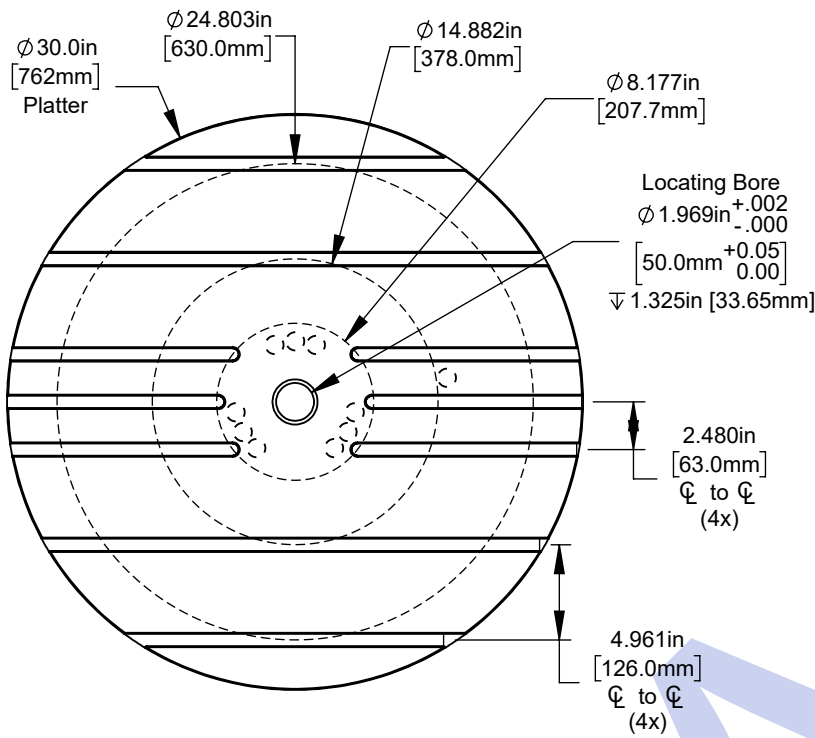

**T-Slot Detail**

**Blank Platter Option**

Drill and tap custom fixturing holes as needed  
 $\nabla 1.500\text{in}$  [38.1mm] maximum hole depth

Do not use existing holes

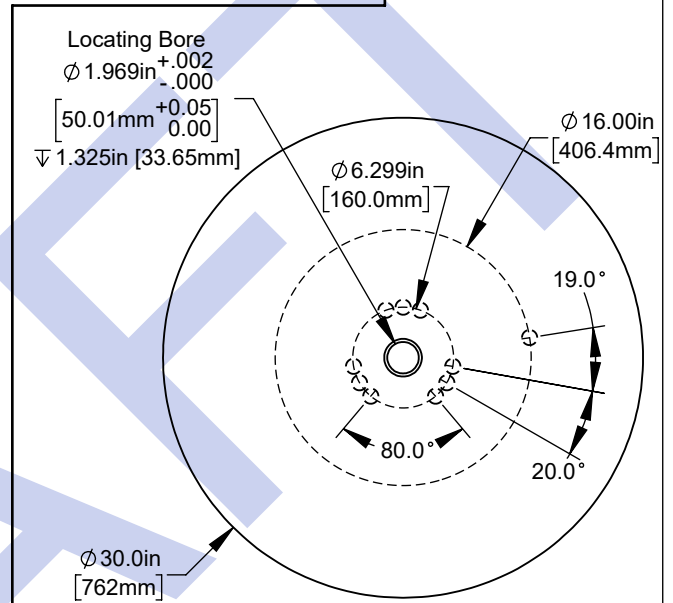

**Note**  
 1. (10x) Phantom holes cannot be used for part fixturing

**Tool Changer**

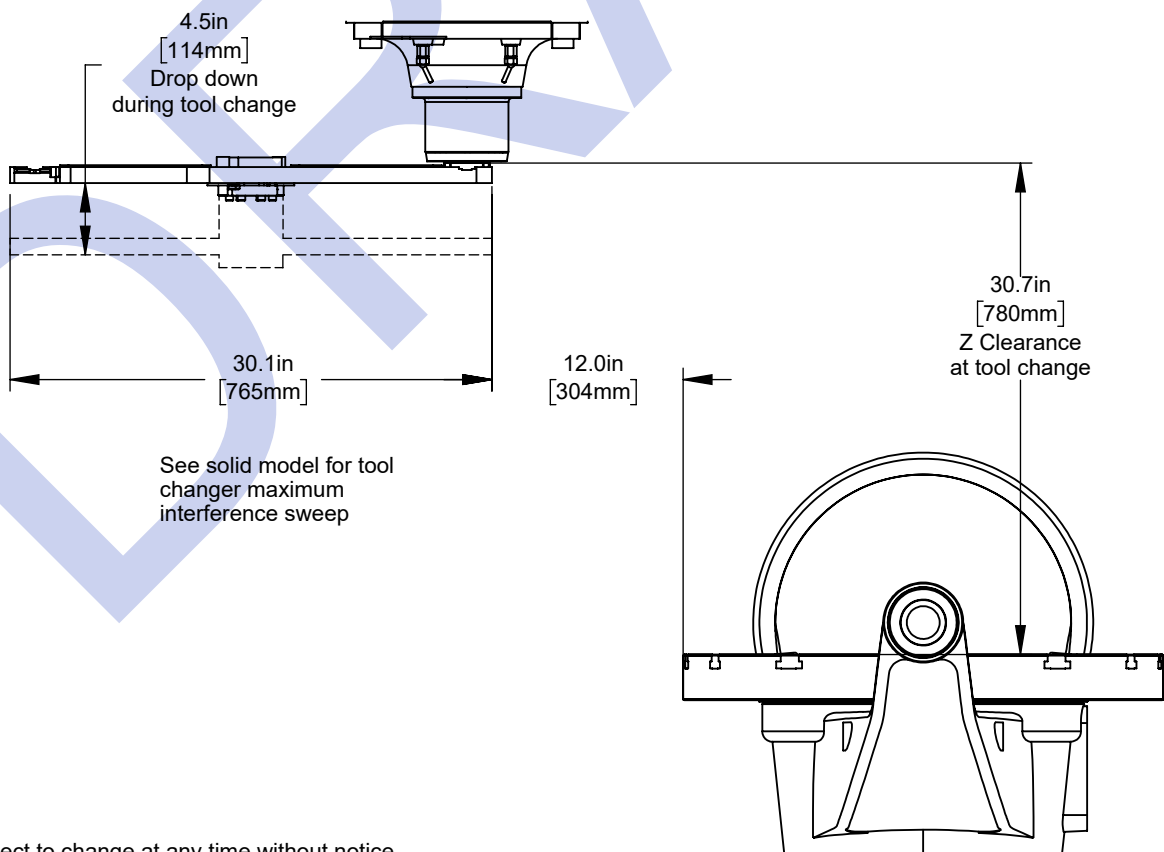

X&Y-Axis Clearance

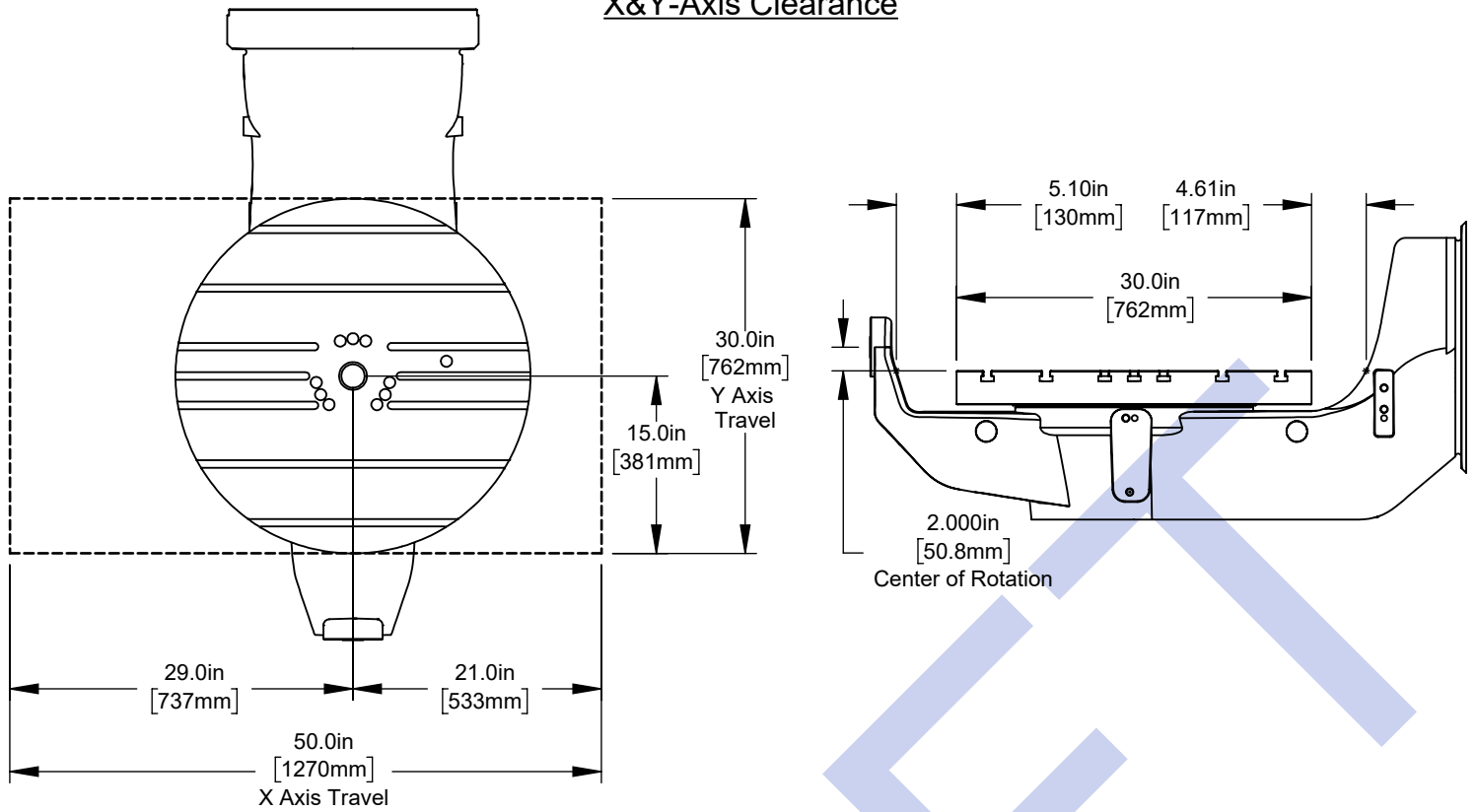

Clearance at B90

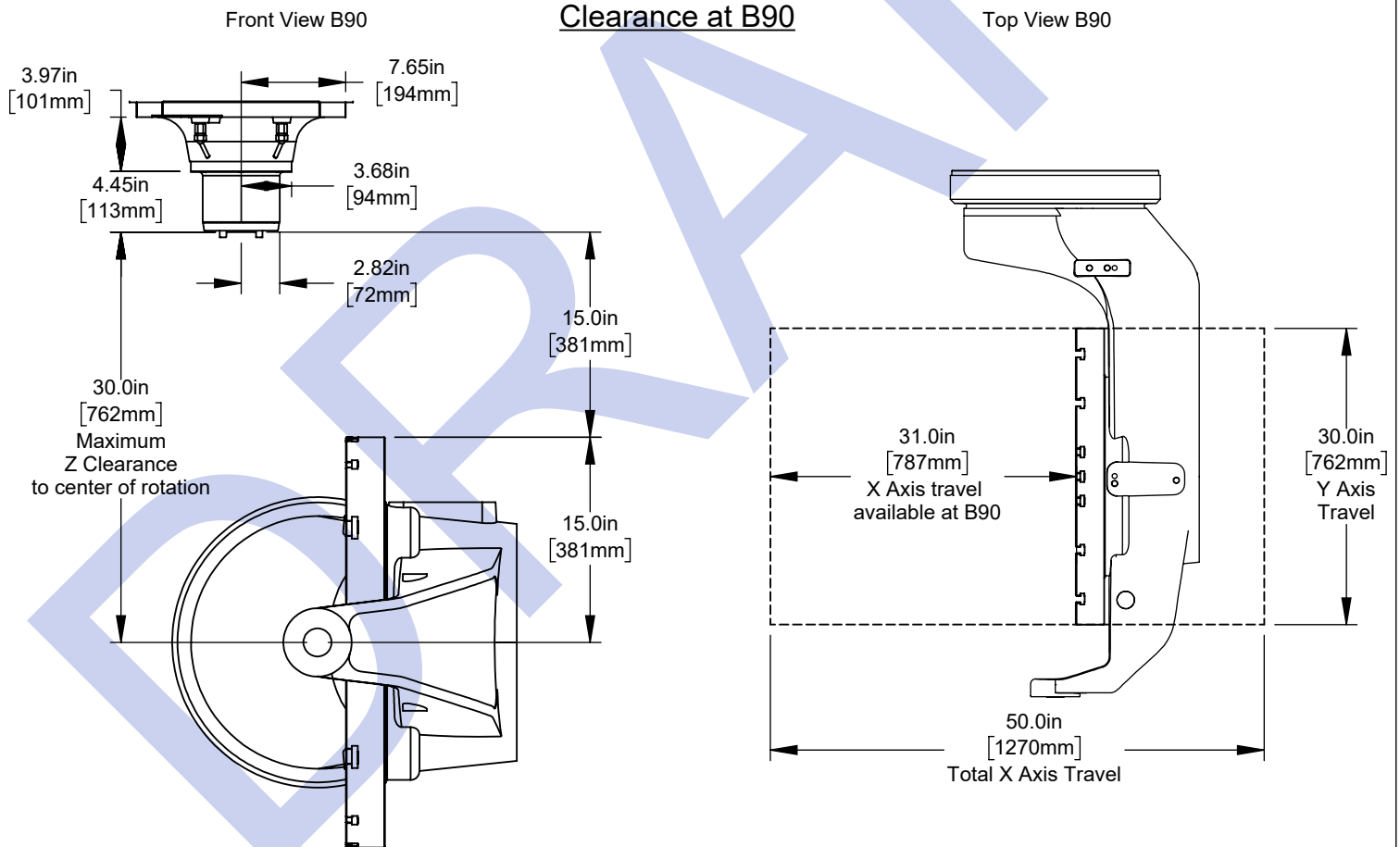

Z-Axis Clearance

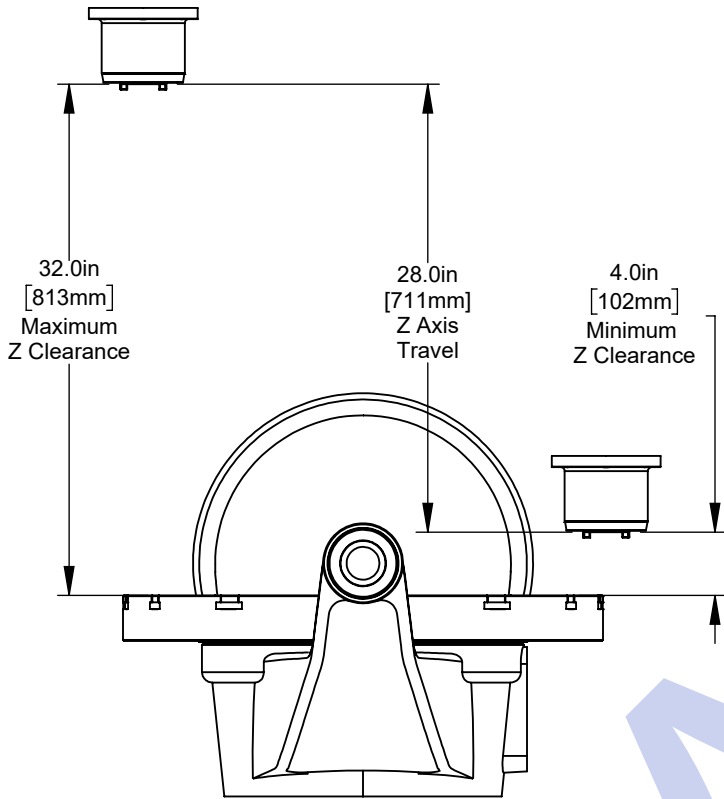
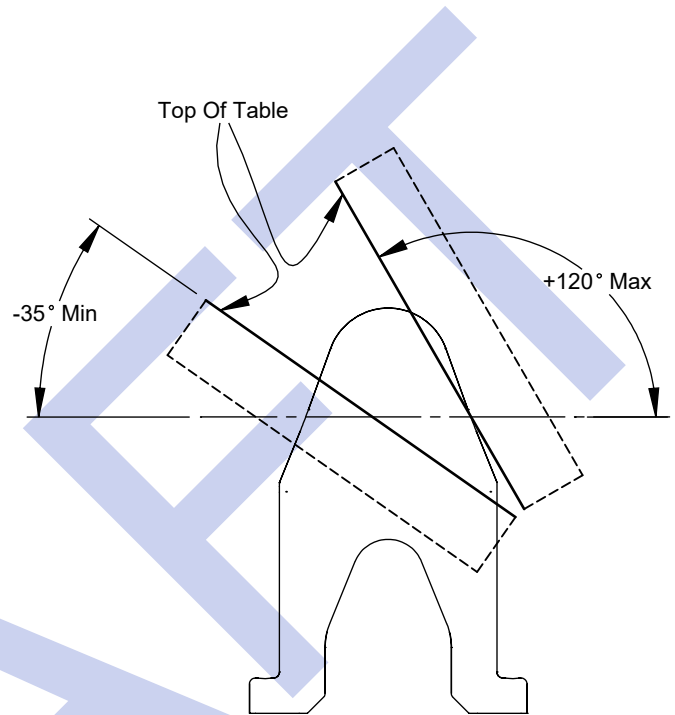
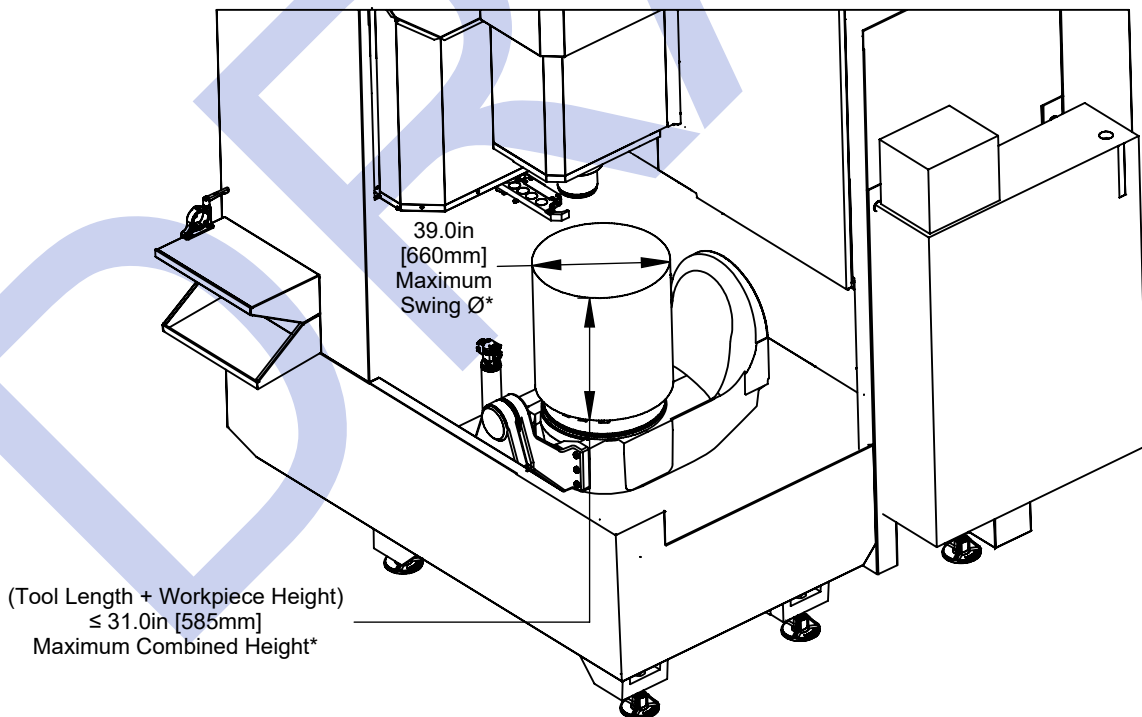

Table Rotation



Work Envelope

*Isometric reference only - not drawn to scale*



**\*Note** - Maximum height and swing apply to B0 orientation only. Large workpieces, including ones within the stated work envelope, may interfere with other machine components as the tilt angle increases. If your part is larger than 30.0in [762mm] diameter or taller than 25in [635mm] it is recommended to review your application's suitability with your local HFO Applications team