

VM-3 Anchor Pattern

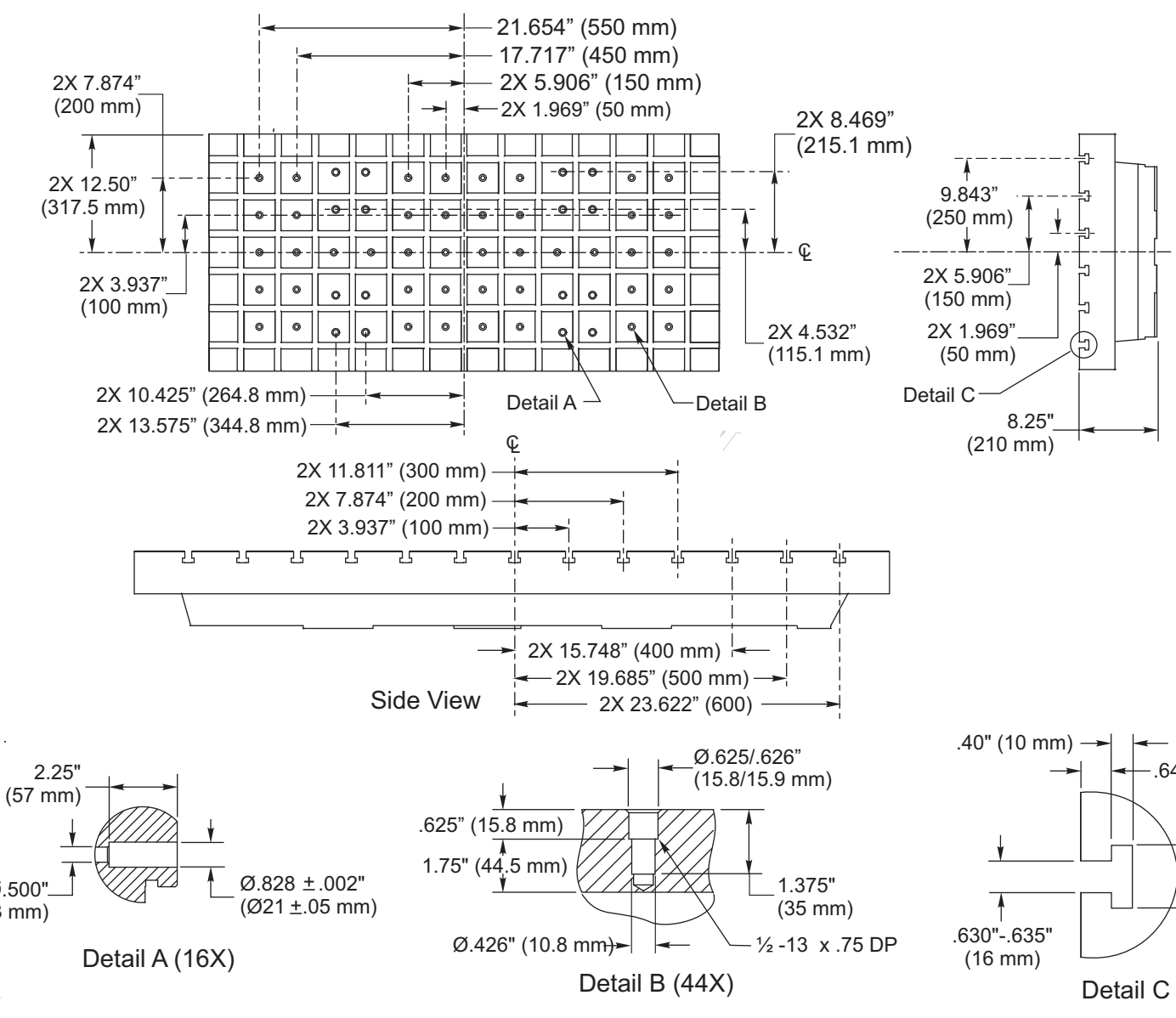

VM-3 Table Dimensions

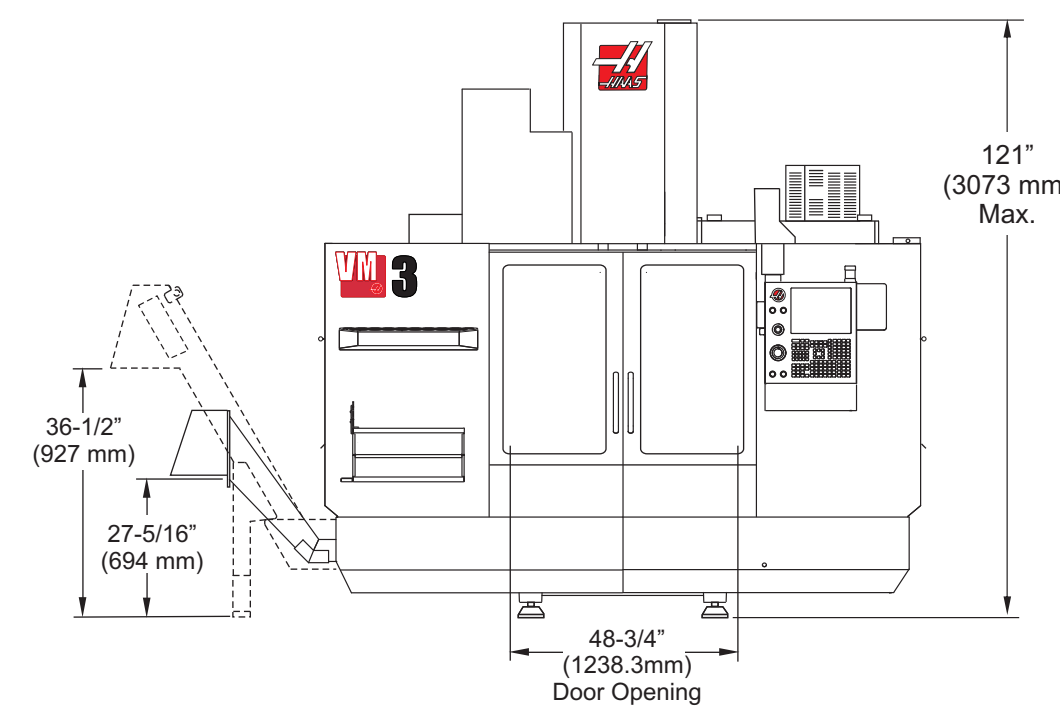
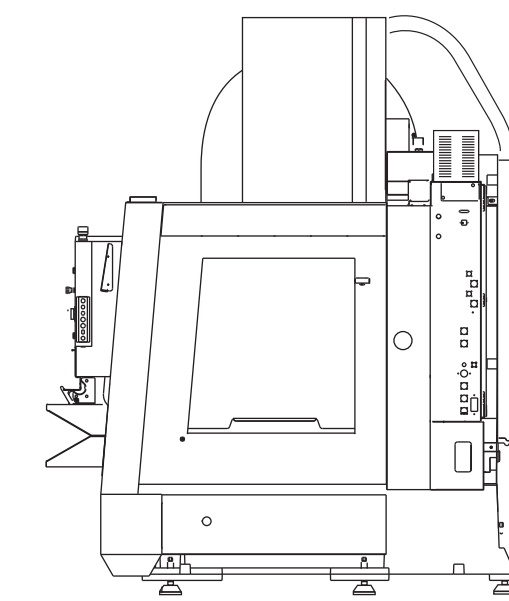
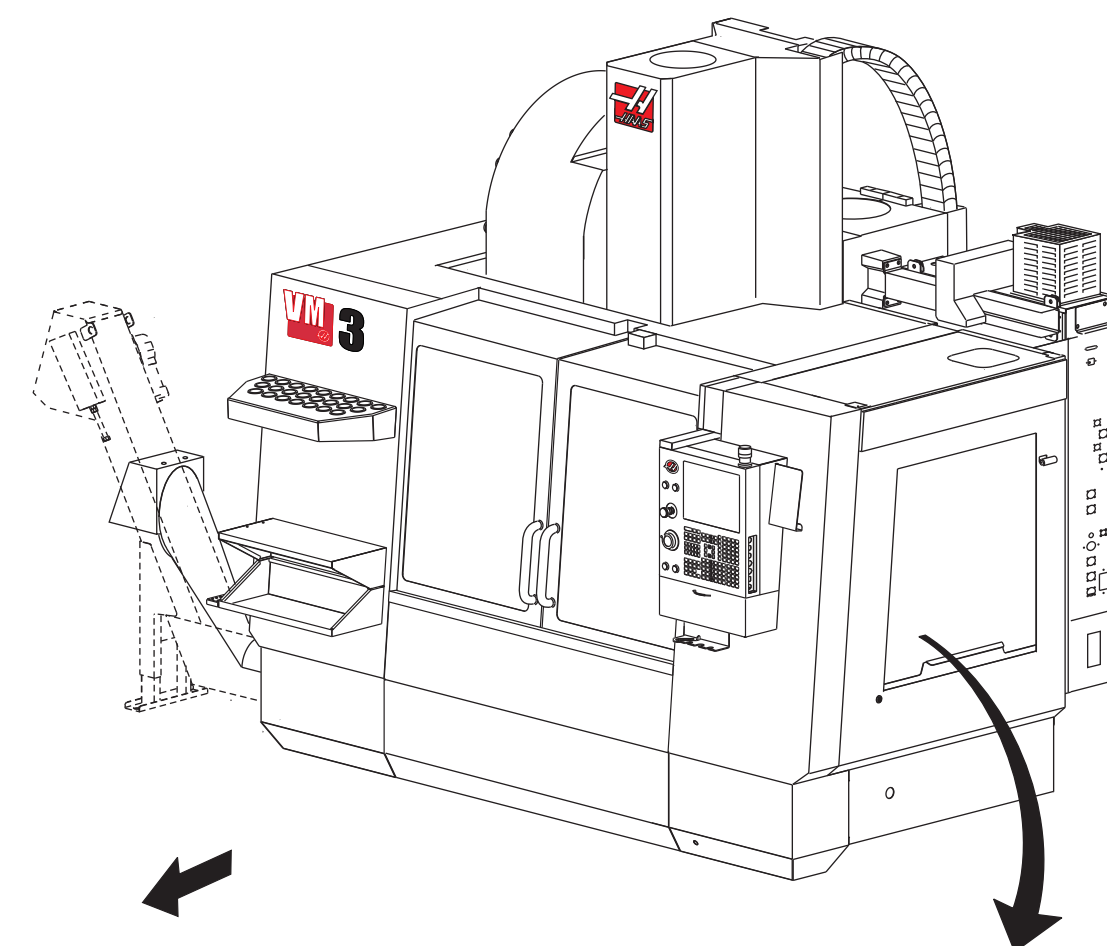
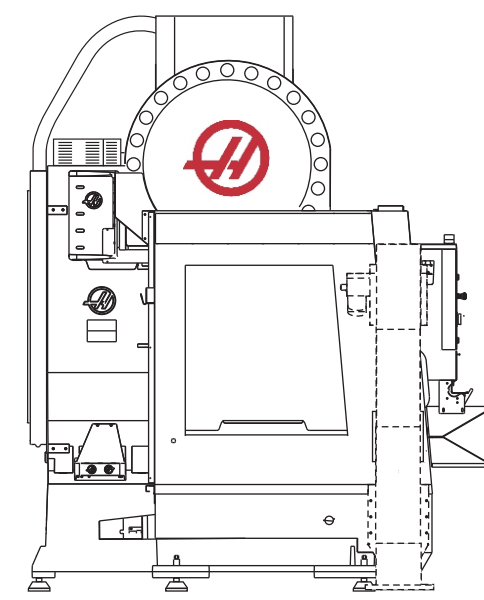
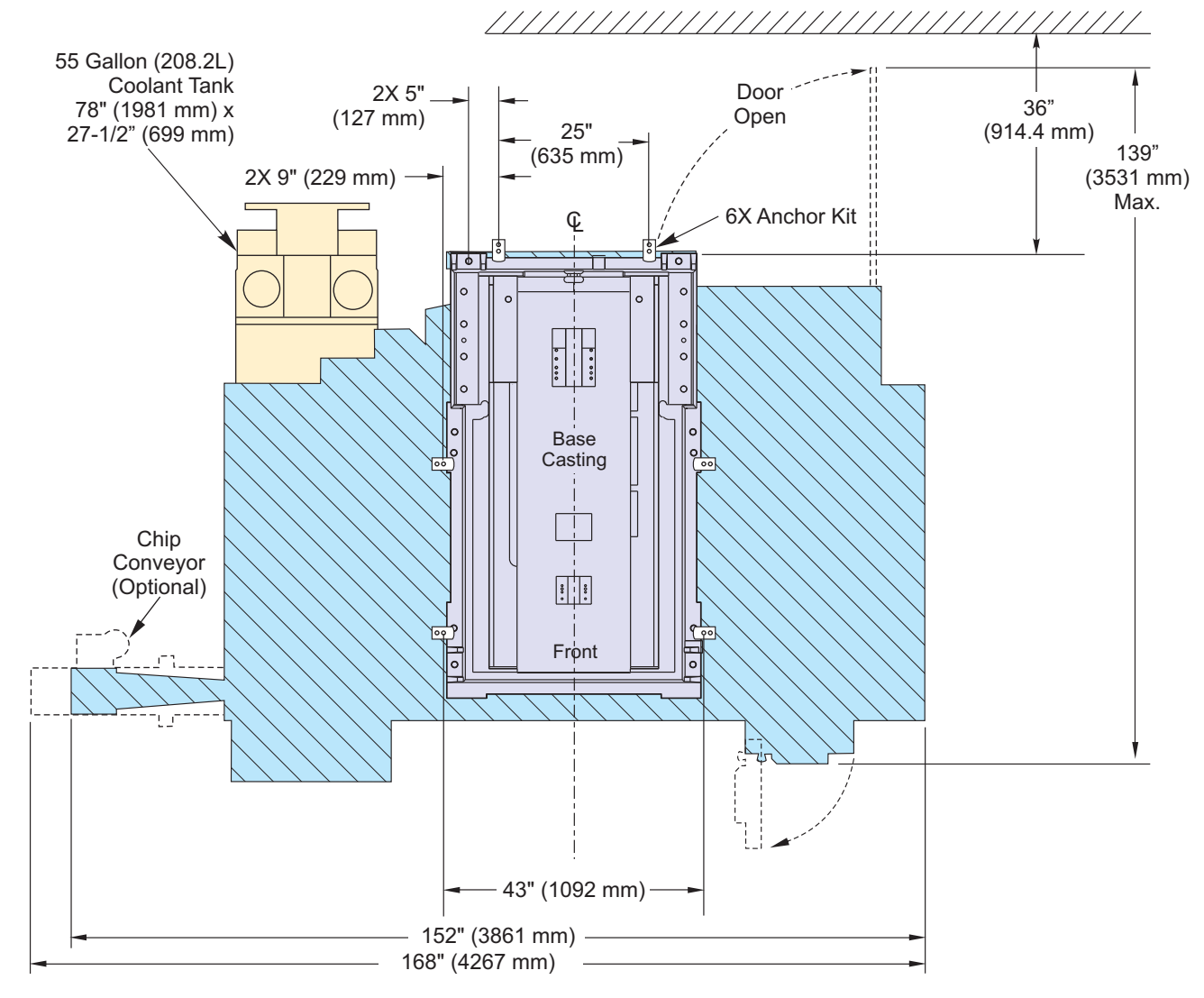
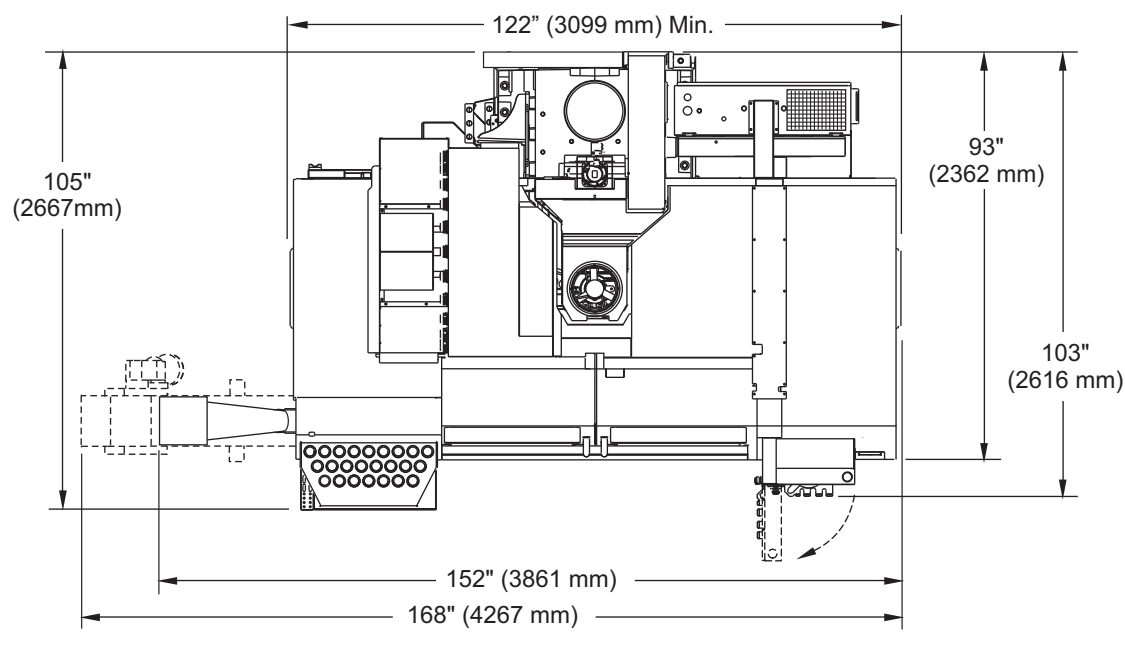
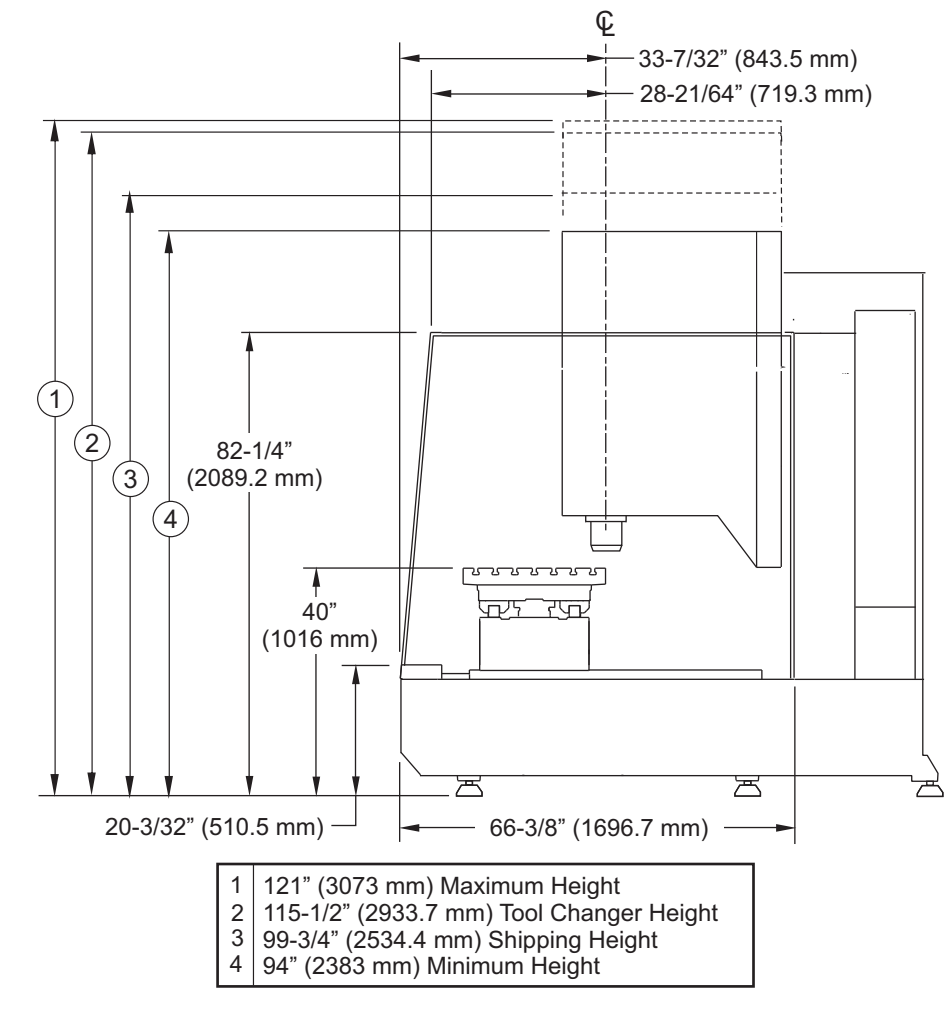

VM-3 Sheet Metal Removed for Clarity

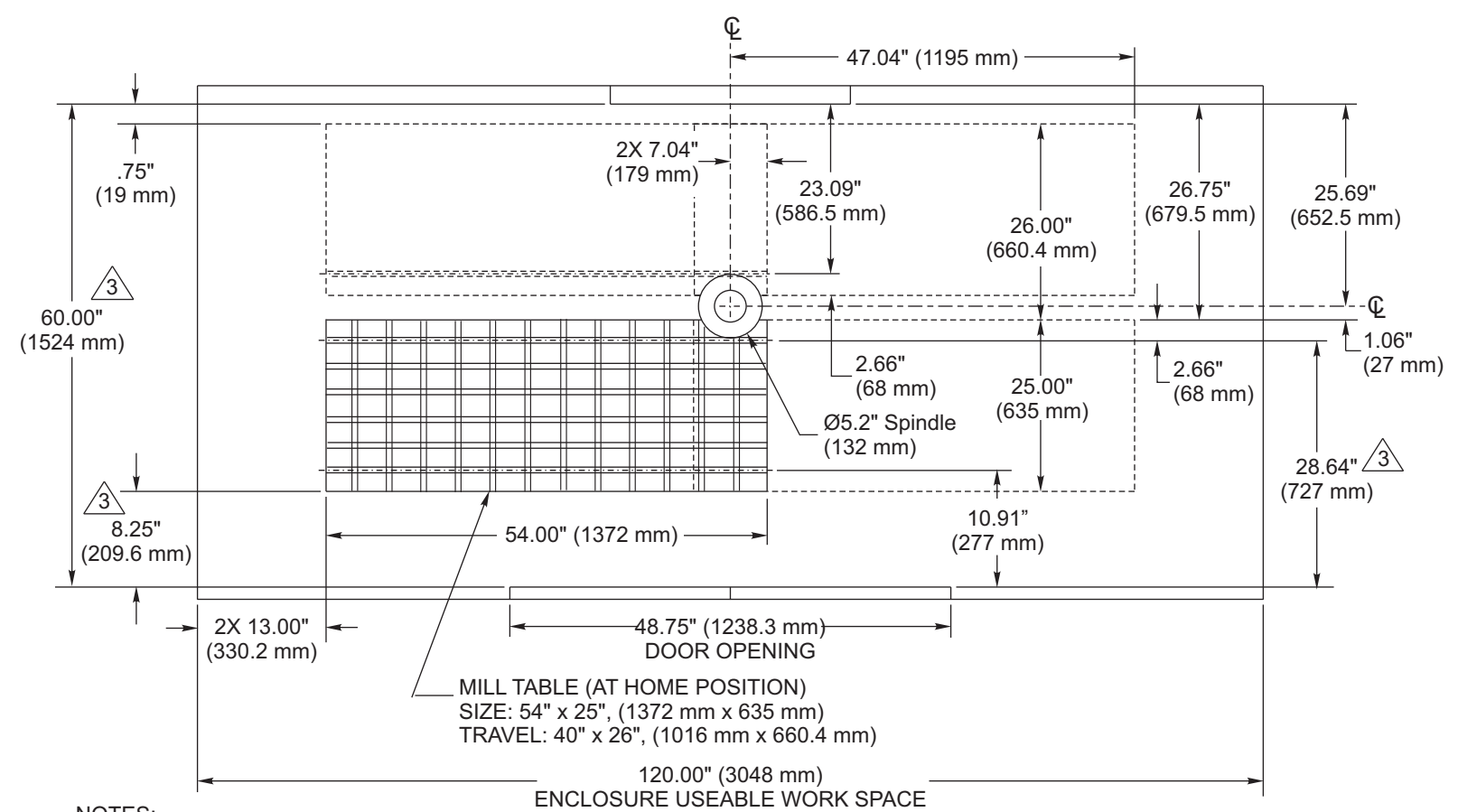

NOTES:
 1. TABLE POSITION(S) AT MAX X & Y TRAVELS.
 2. MEASUREMENTS ARE FROM THE EDGE OF MILL TABLE TO NEAREST OBSTRUCTION (ie. ENCLOSURE, WAY COVER, DOORS, ECT).
 3. DIMENSIONS ARE REDUCED AS HEIGHT ABOVE TABLE INCREASES; ie. FRONT OF ENCLOSURE IS SLOPED 5 INWARD FROM BOTTOM TO TOP. DIMENSIONS SHOWN ARE AT TABLE TOP HEIGHT.

Top View

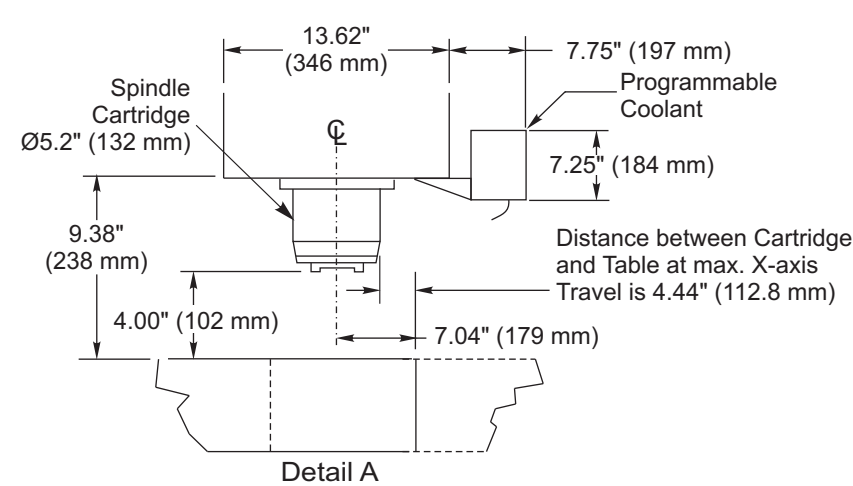

VM-3 Enclosure Usable Work Space

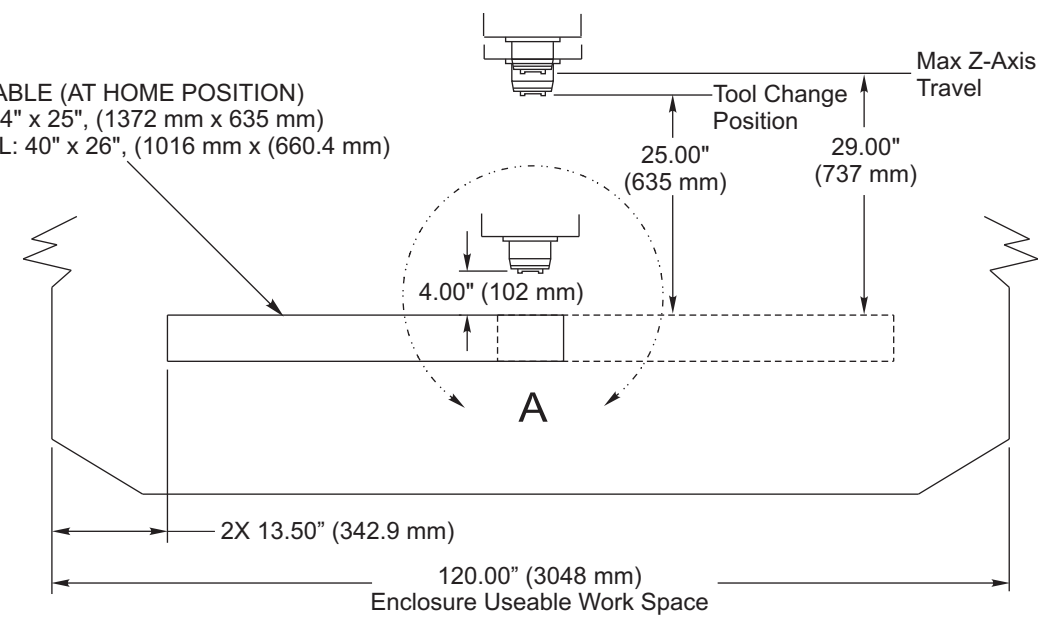

Front View