

VF-9/50 Machine Layout Drawing

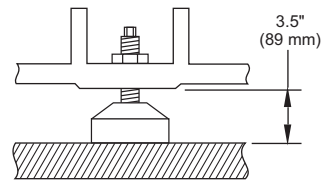

Leveling Pad Pin Dimension

Reference ES0039
Machine Clearance Heights

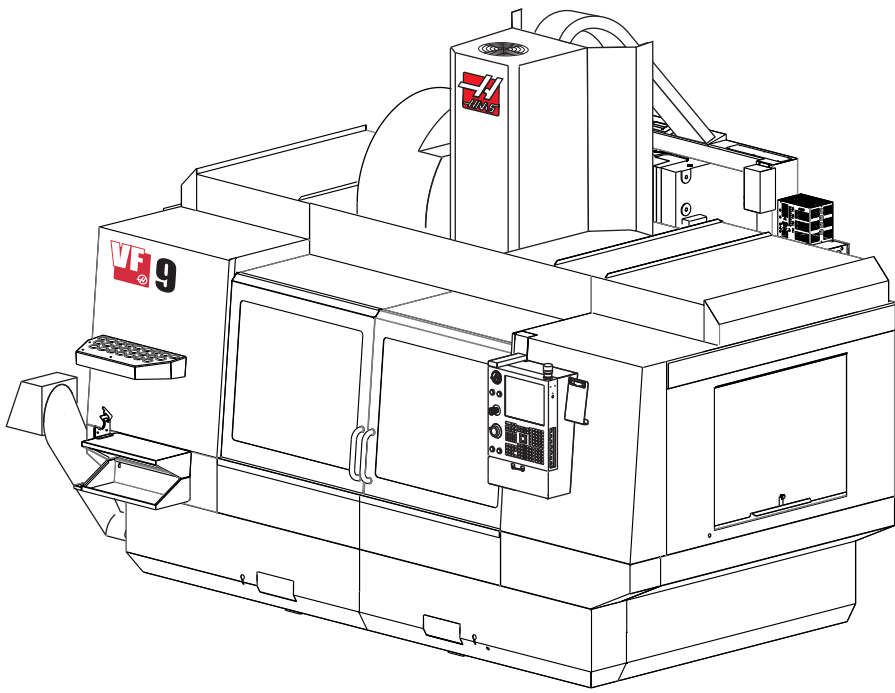
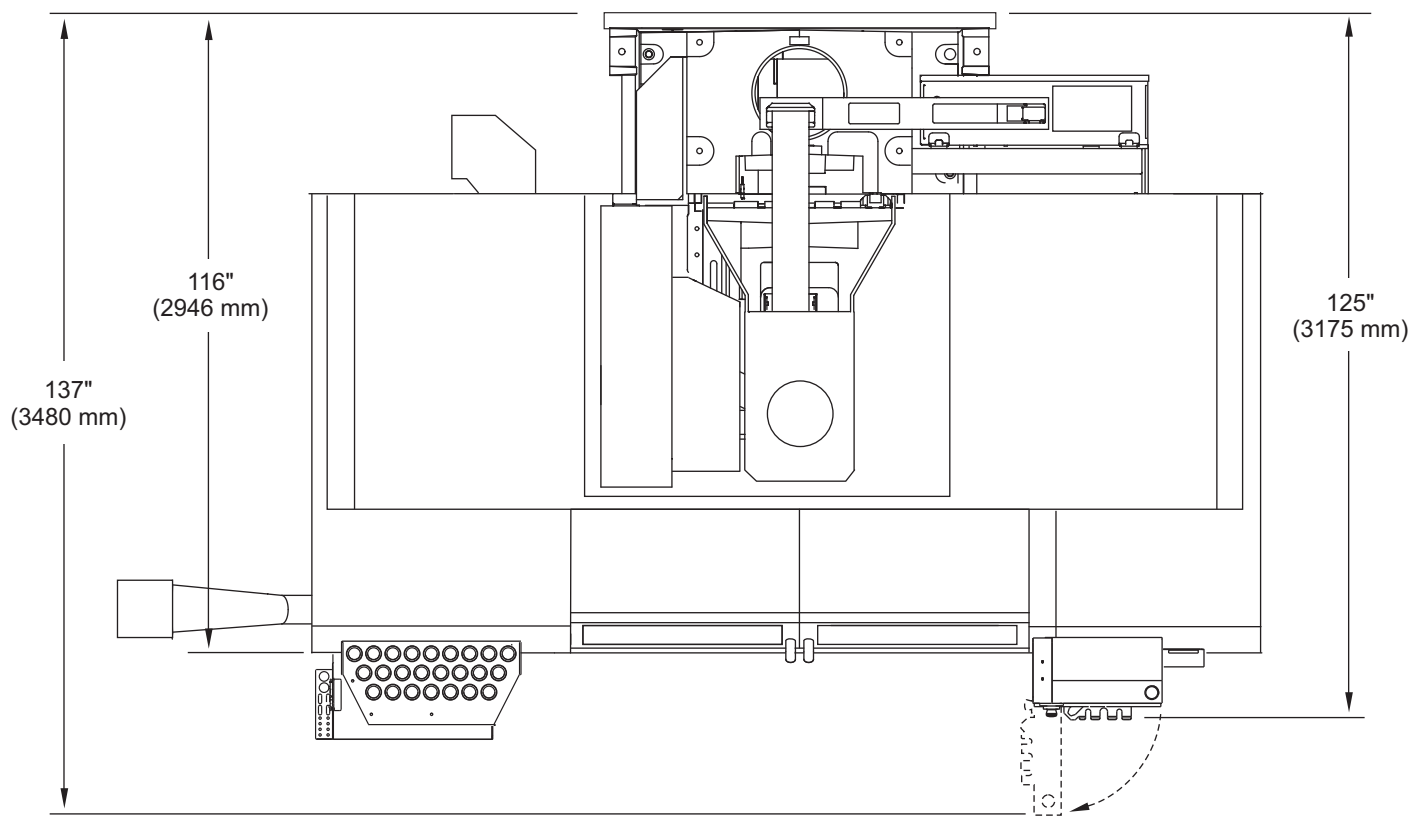
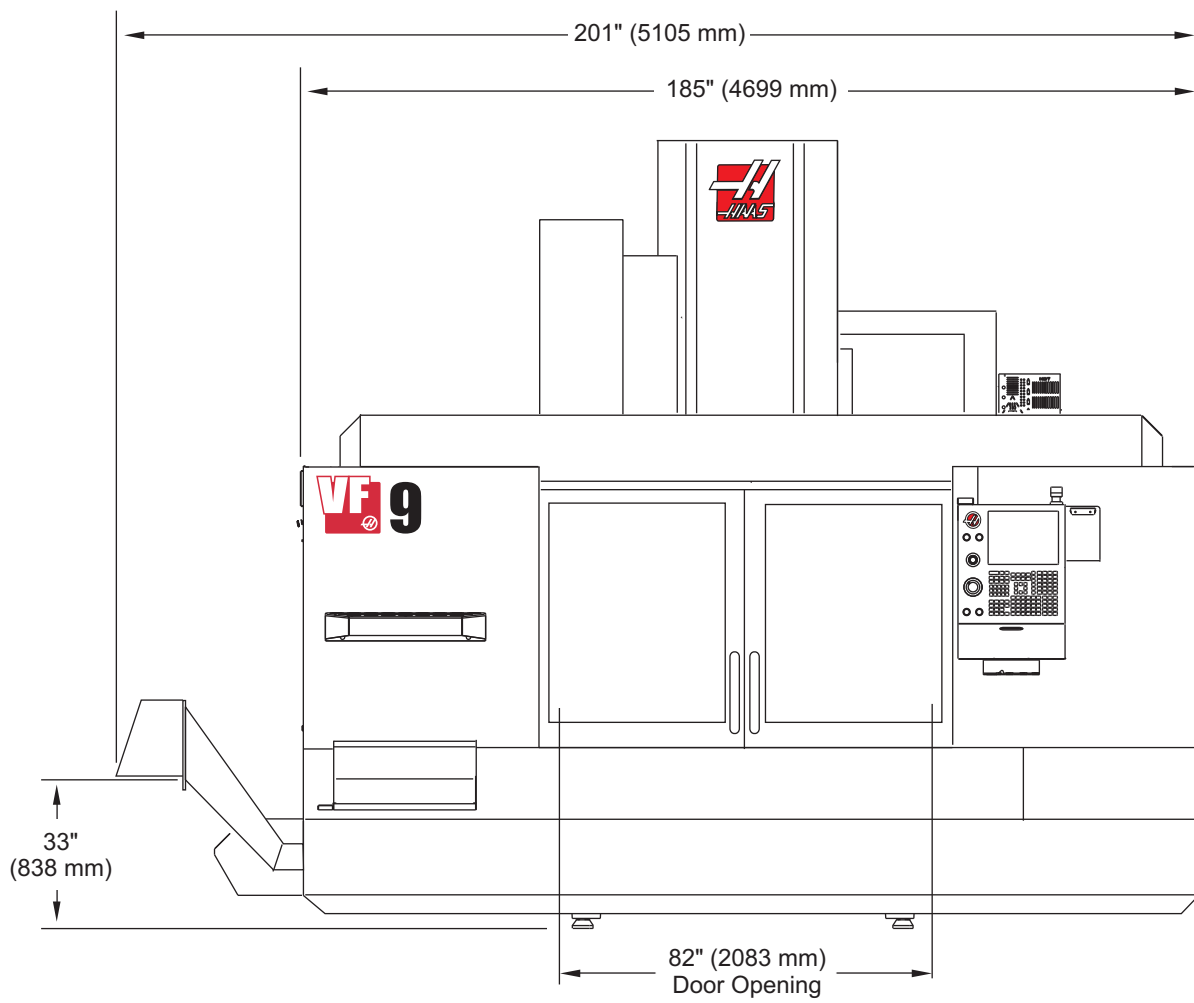

Two-Step Operator Platform included (not shown)

Length: 72.5" (1842 mm)

Width: 23.5" (570 mm)

Height: 12.5" (318 mm)

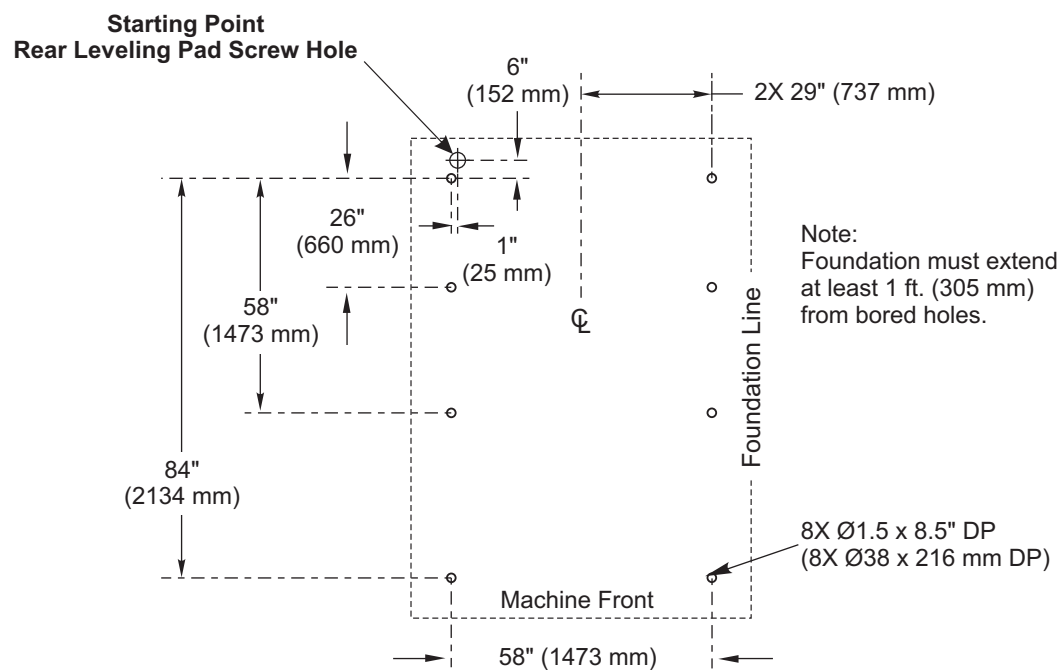
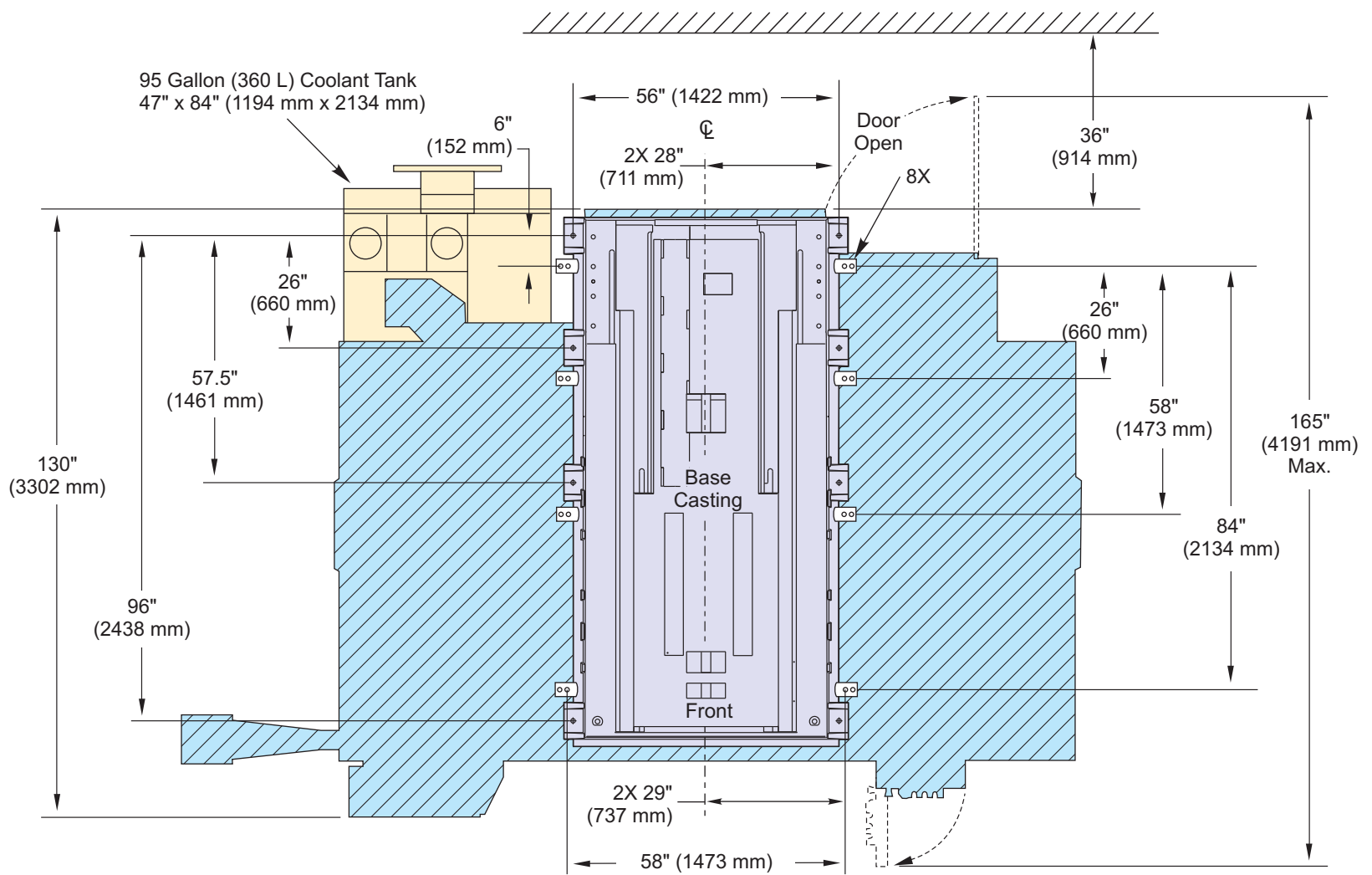
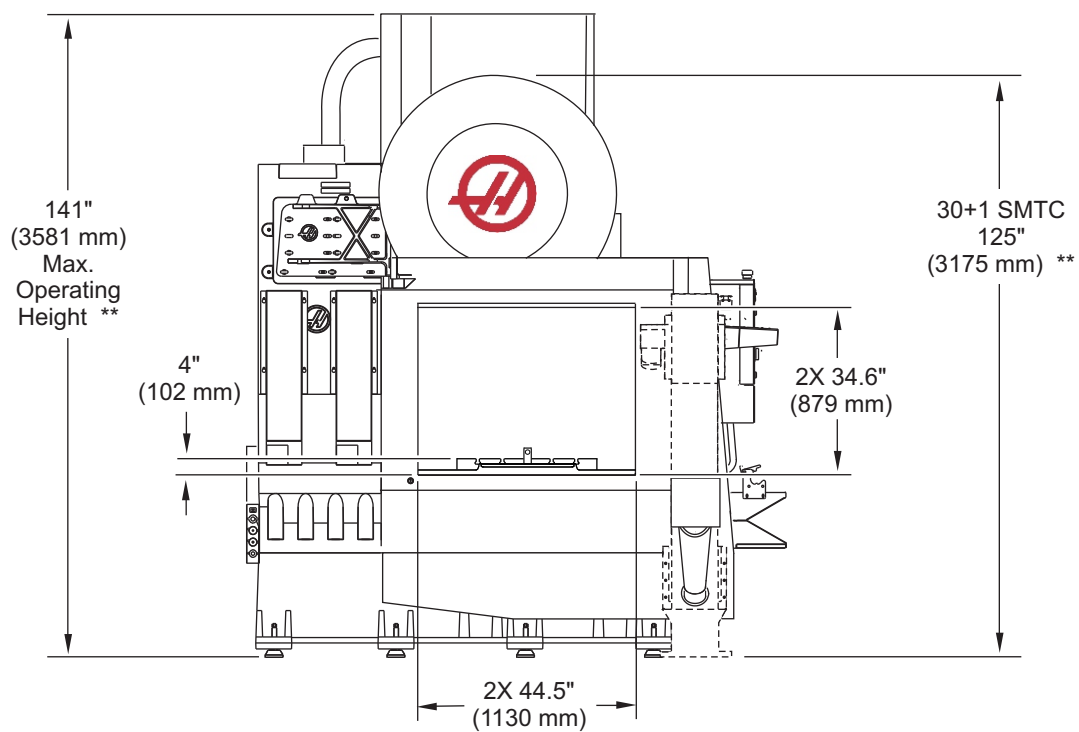

VF-9 Anchor Pattern
 This anchor pattern applies for machines
 built after January 2013.

VF-9/50 Work Space Envelope

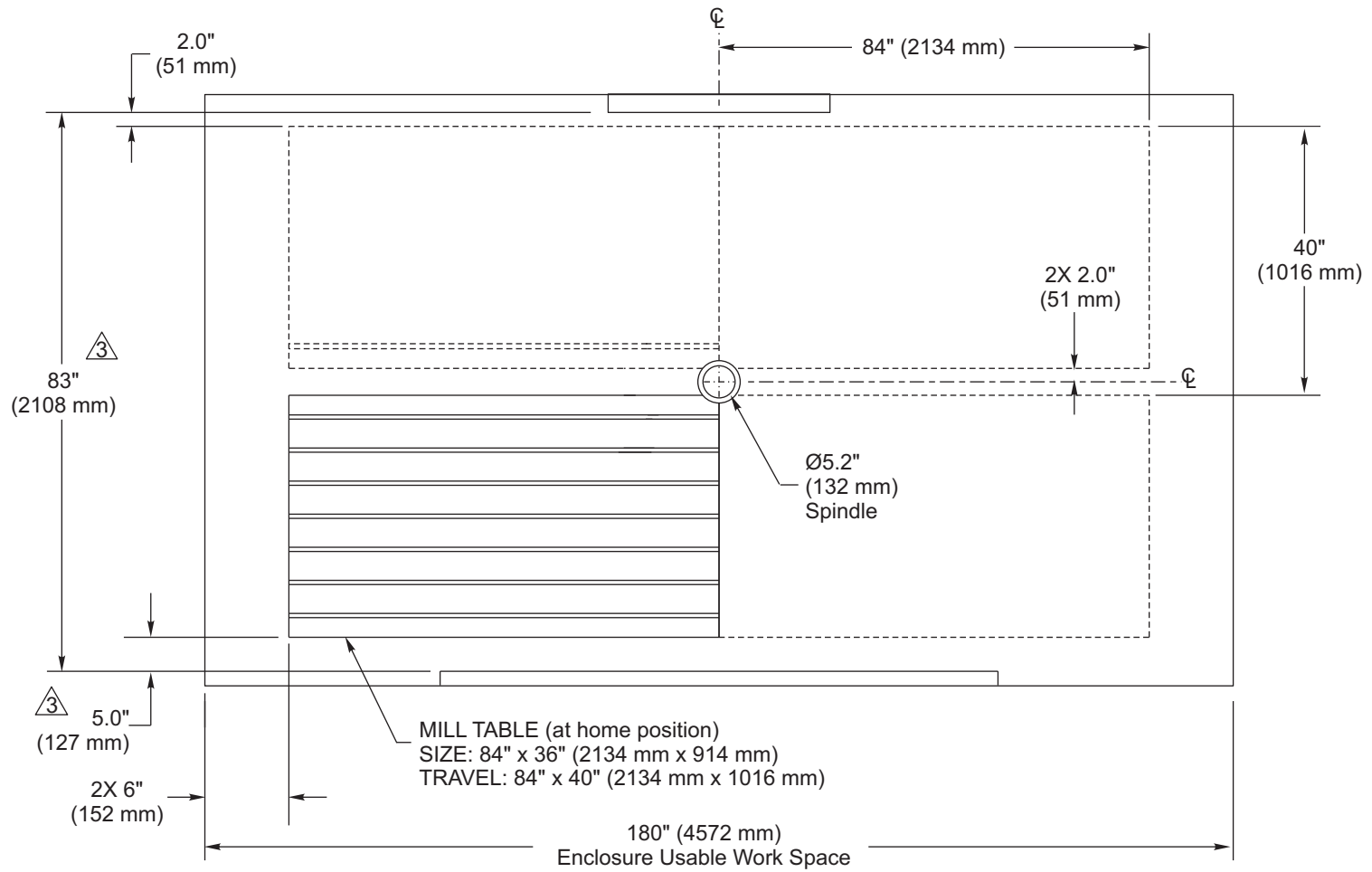

NOTES:

1. TABLE POSITION(S) AT MAX X & Y TRAVELS.
2. MEASUREMENTS ARE FROM THE EDGE OF MILL TABLE TO NEAREST OBSTRUCTION (ie. ENCLOSURE, WAY COVER, DOORS, ETC.).
3. DIMENSIONS ARE REDUCED AS HEIGHT ABOVE TABLE INCREASES; ie. FRONT OF ENCLOSURE IS SLOPED 5° INWARD FROM BOTTOM TO TOP. DIMENSIONS SHOWN ARE AT TABLE TOP HEIGHT.

Top View

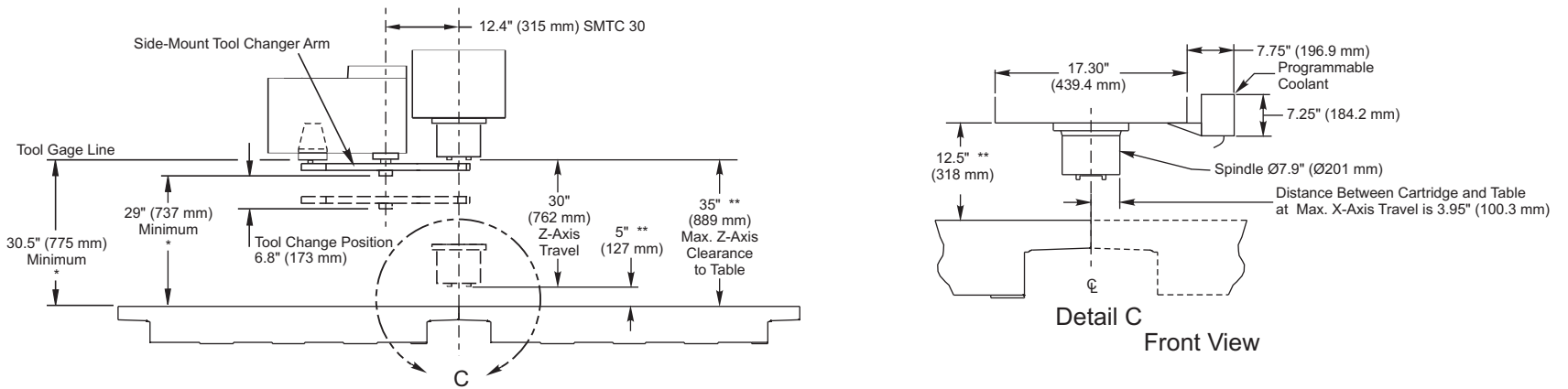

Front View

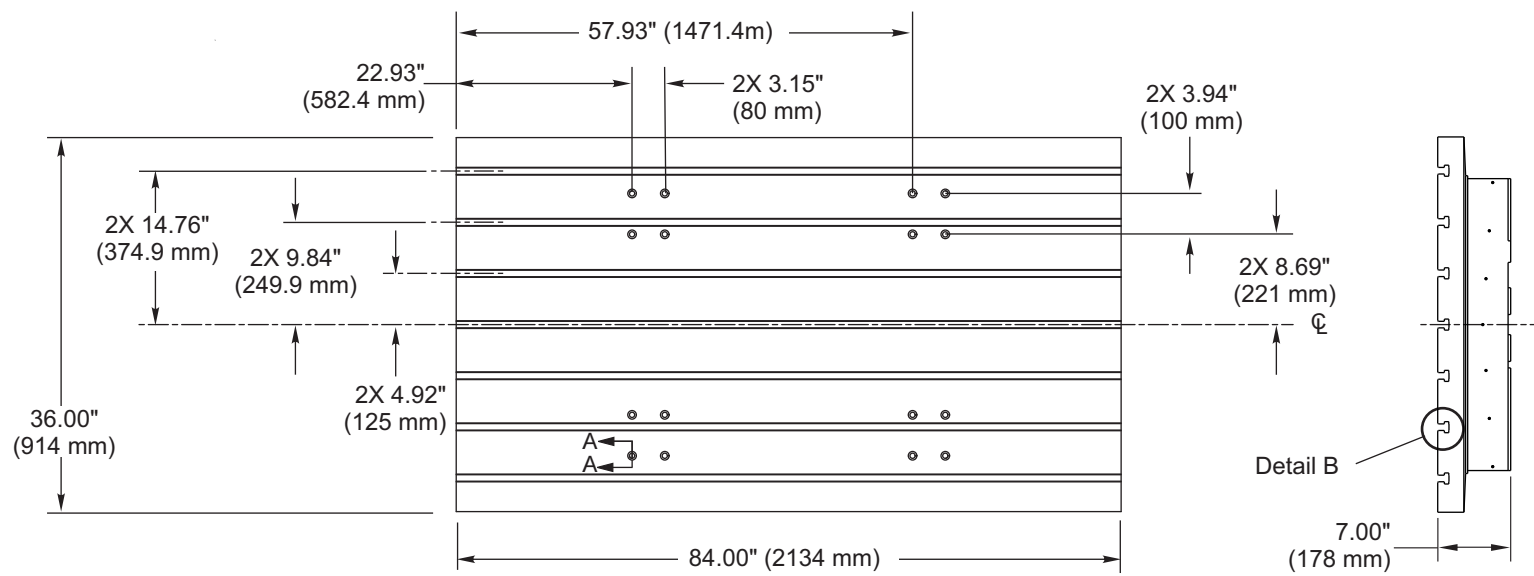

VF-9 Table Dimensions

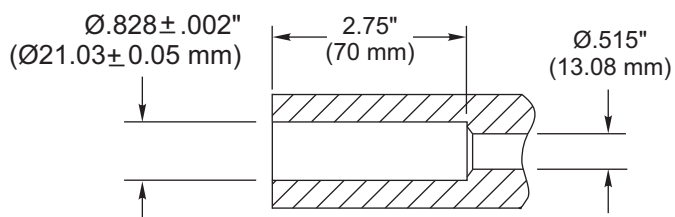

Section A-A (16X)

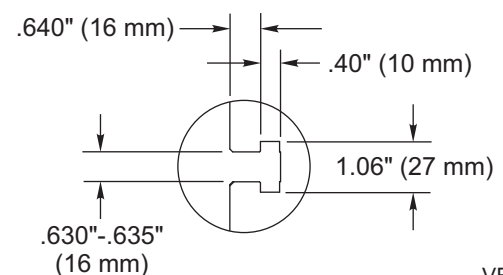

Detail B (7X)