

Leveling Pad Pin Dimension

- ① Electrical Connection
- ② Air Connection

VF-8 Anchor Pattern
This anchor pattern applies for machines built after January 2013.

Two-Step Operator Platform included (not shown)
Length: 72.5" (1842 mm)
Width: 23.5" (570 mm)
Height: 12.5" (318 mm)

** Extended Z-Axis Clearance Option add 8" (203 mm)

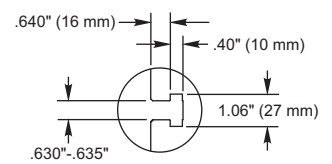
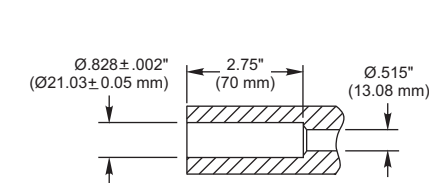
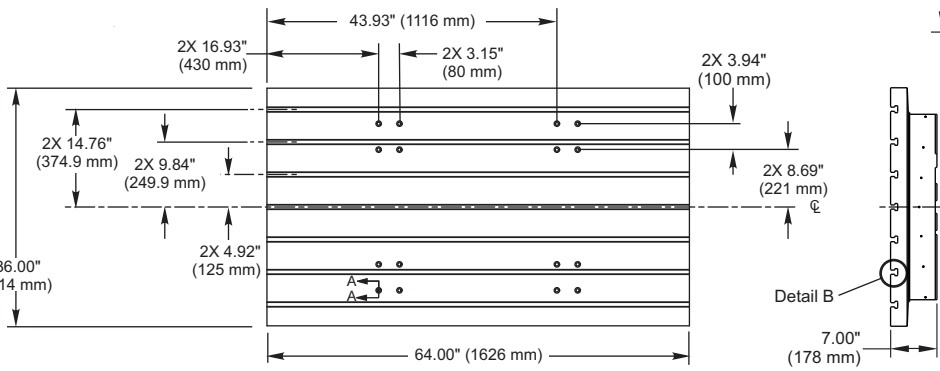
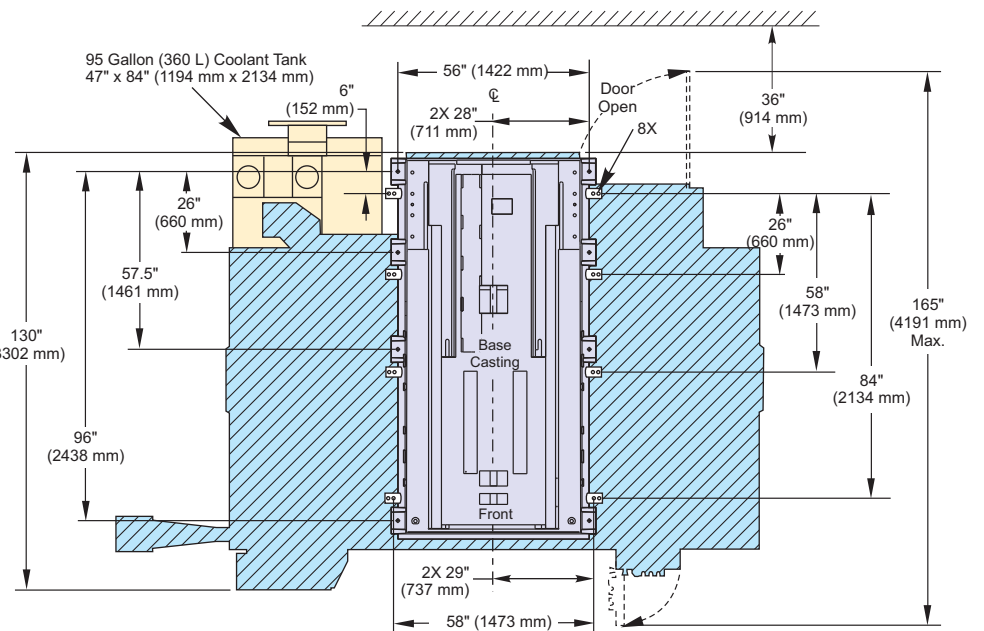
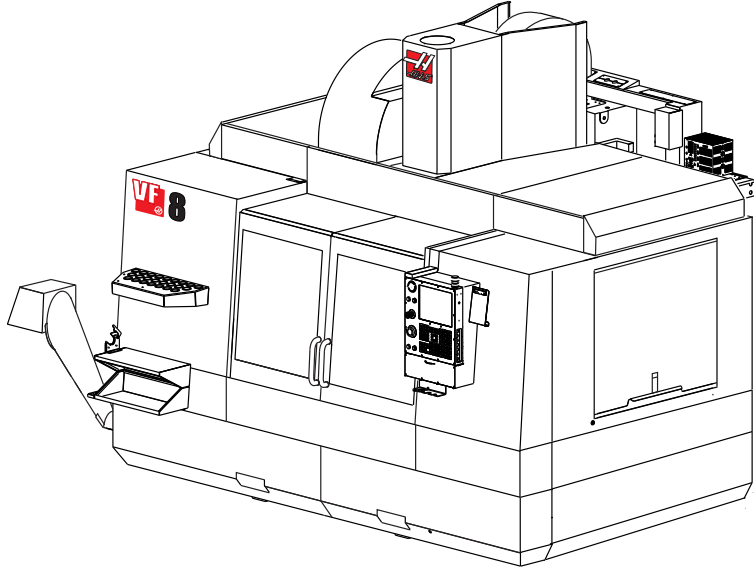
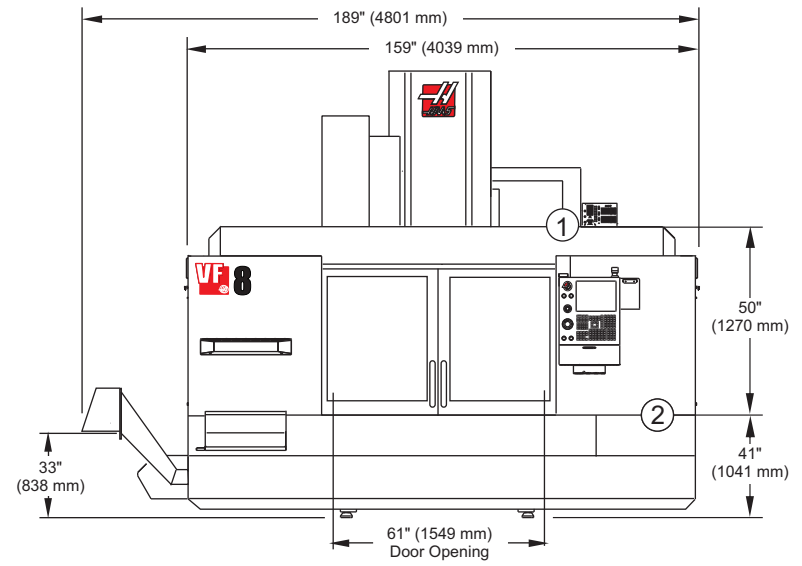
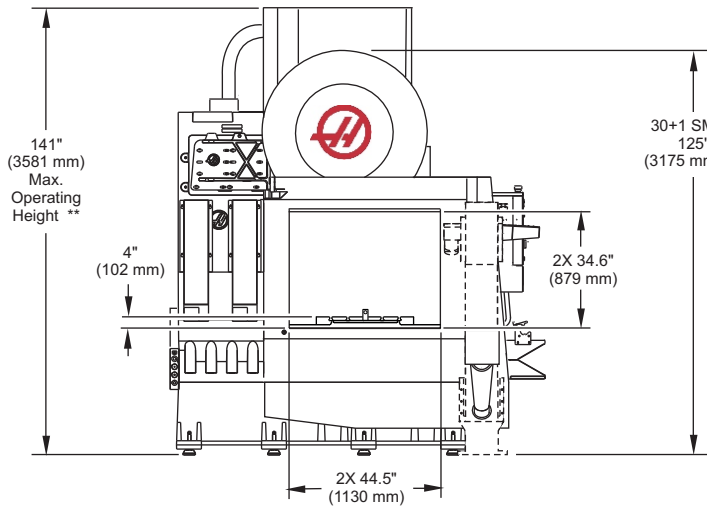
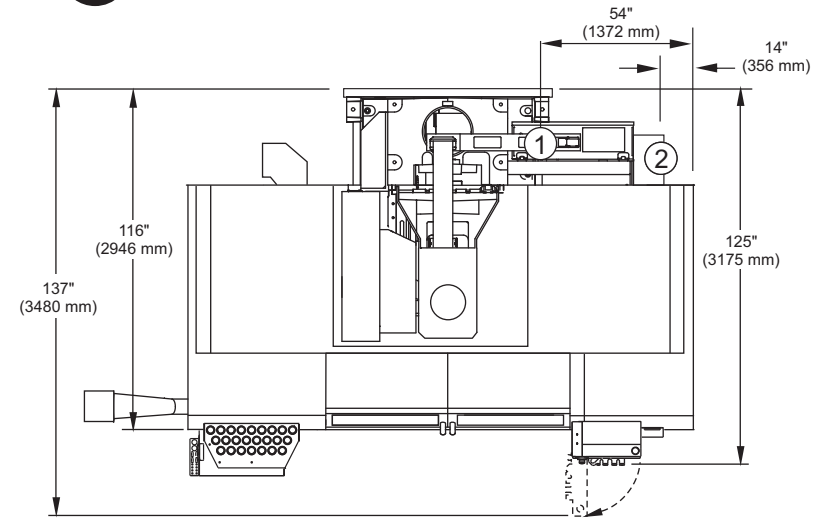

Section A-A (16X)

Detail B (7X)

VF-8 Table Dimensions

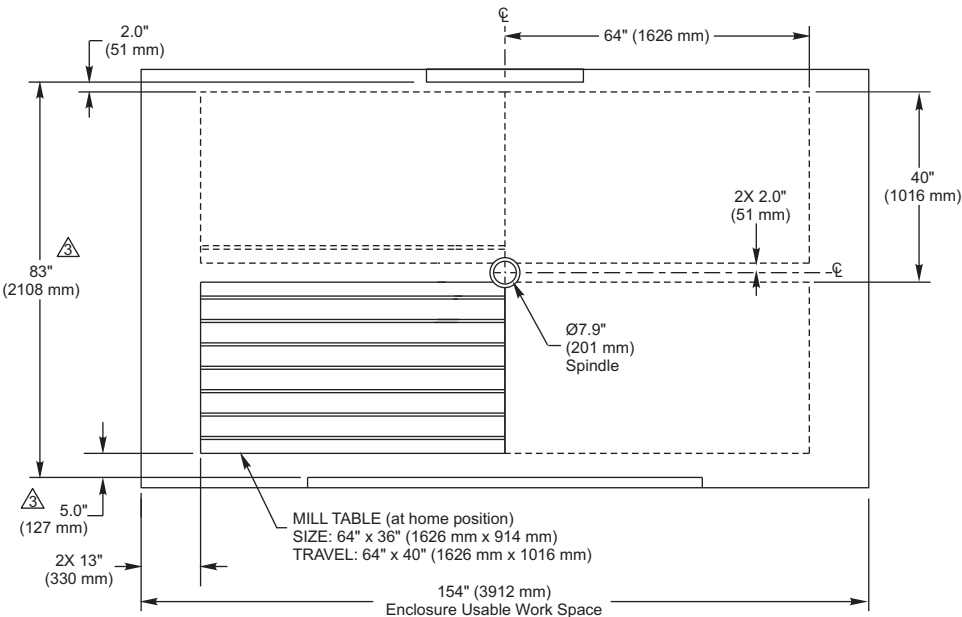

- NOTES:
1. TABLE POSITION(S) AT MAX X & Y TRAVELS.
 2. MEASUREMENTS ARE FROM THE EDGE OF MILL TABLE TO NEAREST OBSTRUCTION (ie. ENCLOSURE, WAY COVER, DOORS, ETC.).
 3. DIMENSIONS ARE REDUCED AS HEIGHT ABOVE TABLE INCREASES; ie. FRONT OF ENCLOSURE IS SLOPED 5° INWARD FROM BOTTOM TO TOP. DIMENSIONS SHOWN ARE AT TABLE TOP HEIGHT.

Top View

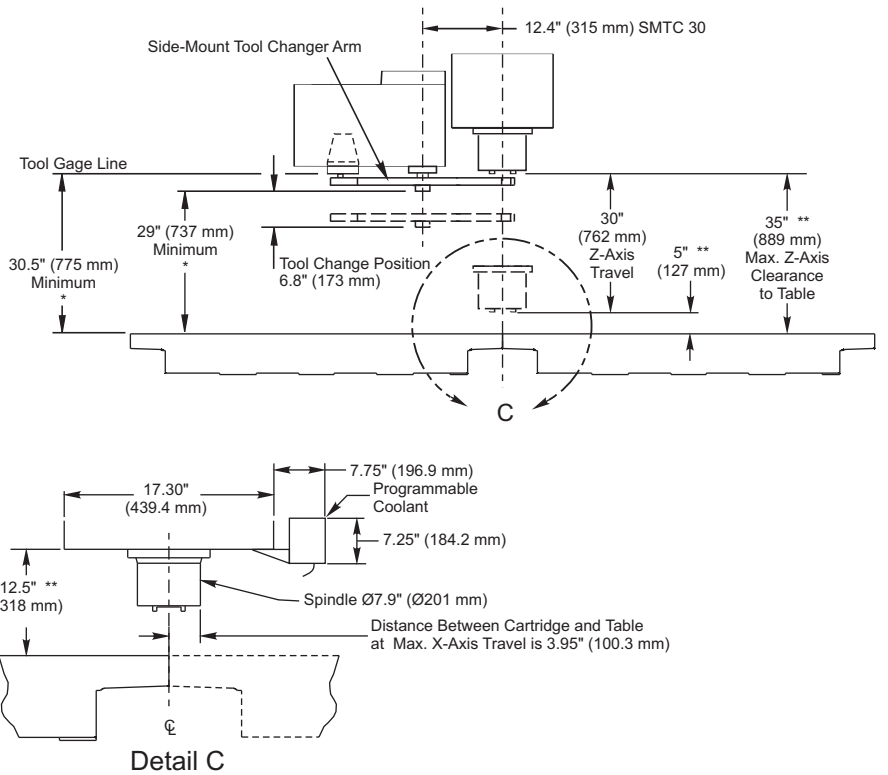

Detail C

Front View

VF-8/50 Enclosure Usable Work Space