

VF-7 Anchor Pattern

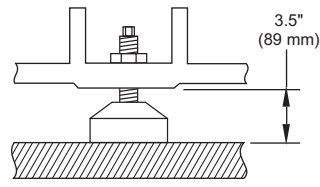

Leveling Pad Pin Dimension

Reference ES0039
Machine Clearance Heights

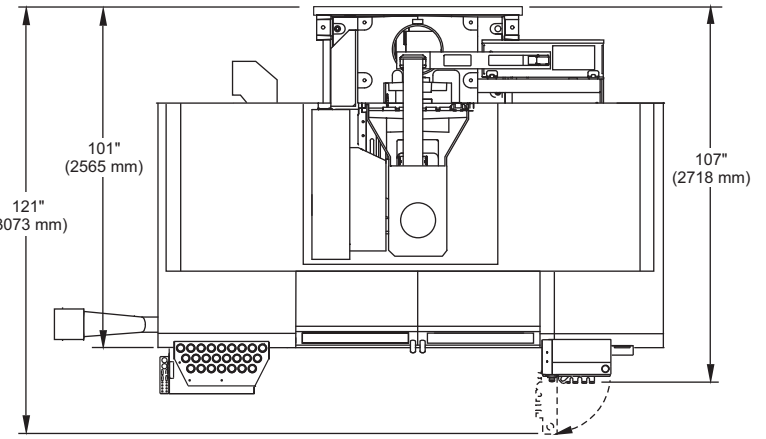

** Extended Z-Axis Clearance Option
add 8" (203 mm)

Two-Step Operator Platform included (not shown)
Length: 72.5" (1842 mm)
Width: 23.5" (570 mm)
Height: 12.5" (318 mm)

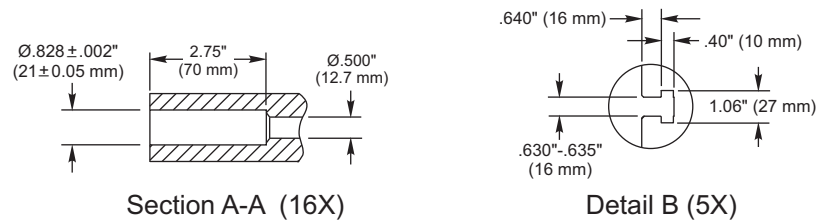
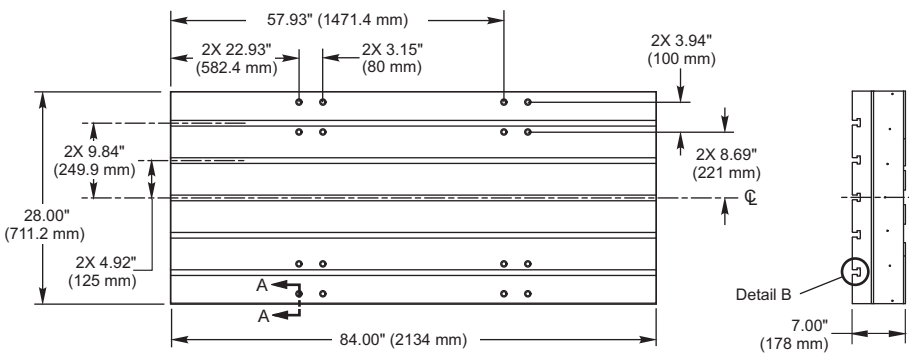
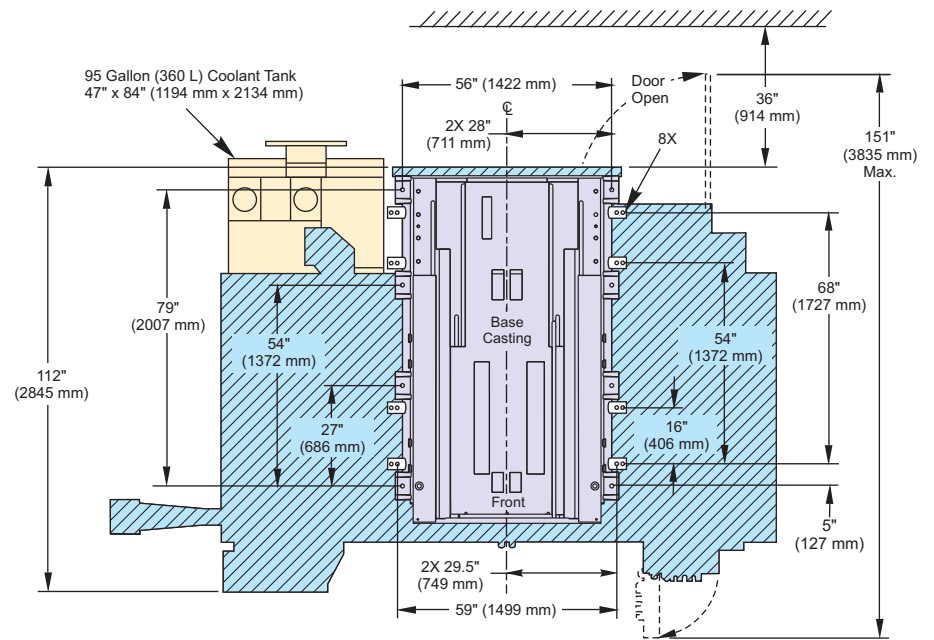
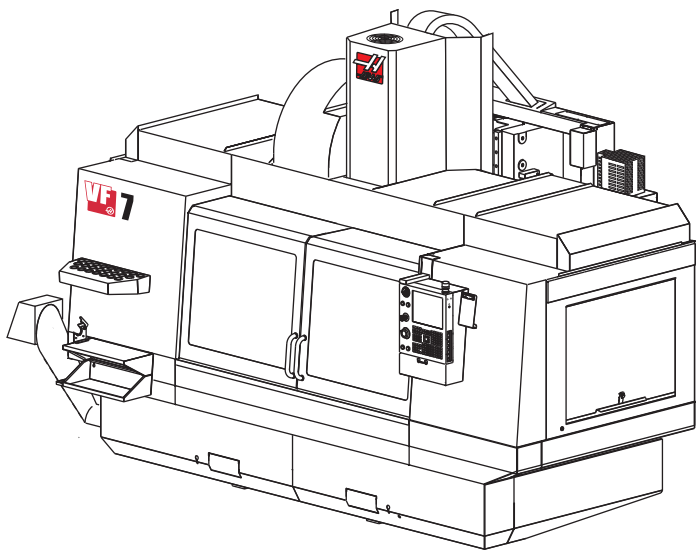
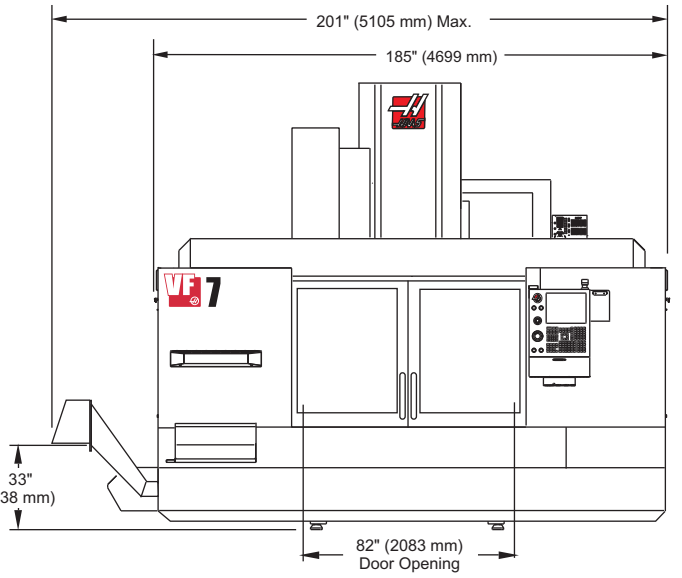
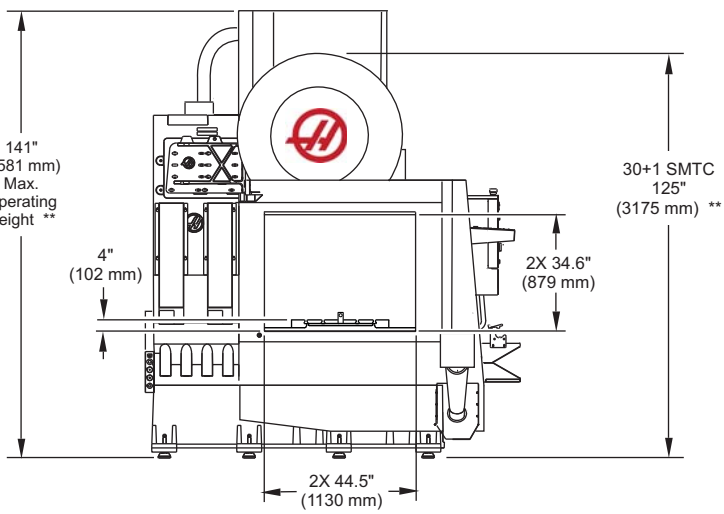

VF-7 Table Dimensions

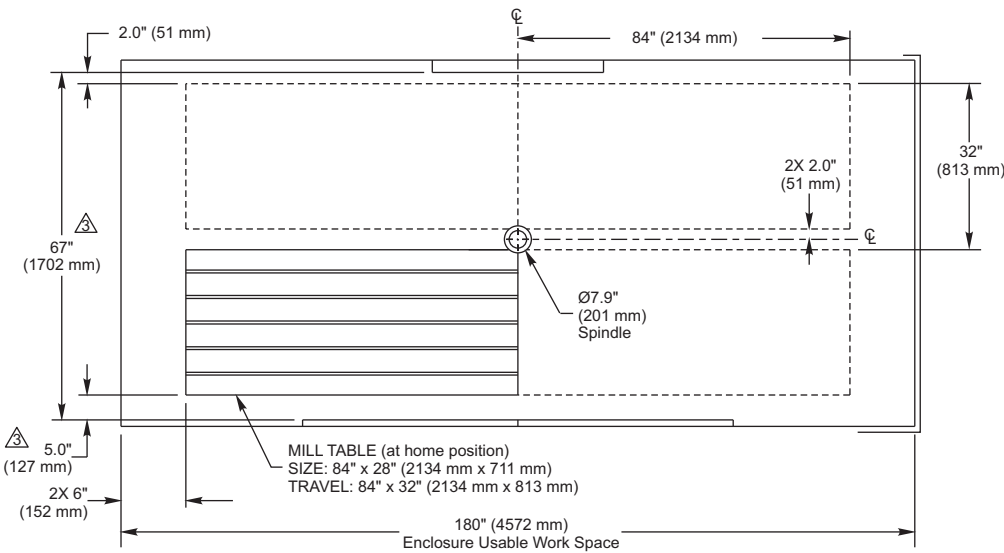

Top View

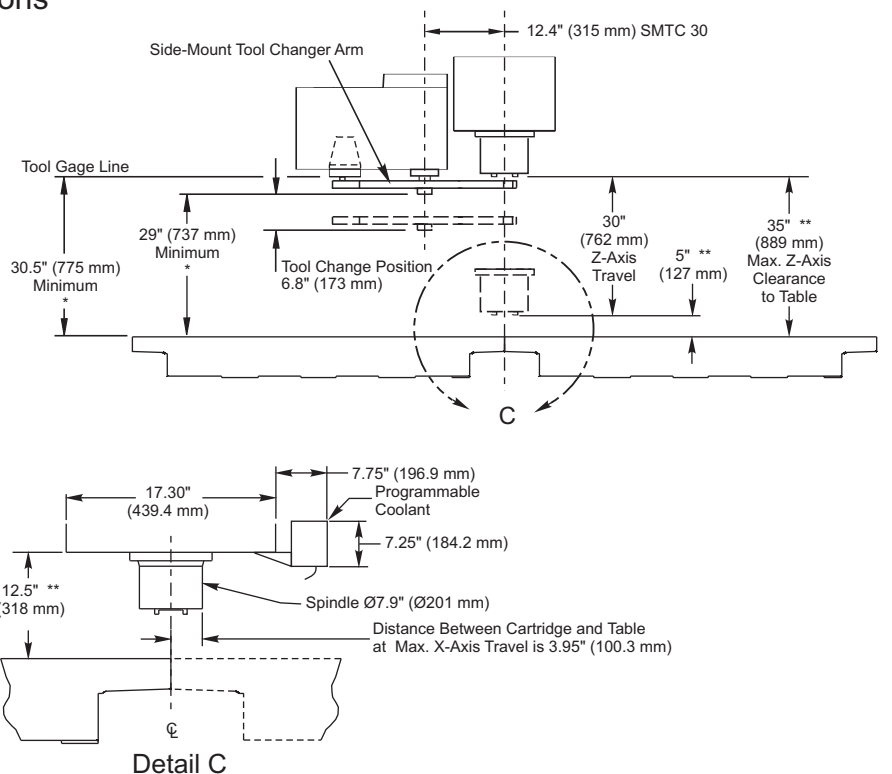

Front View

VF-7/50 Enclosure Usable Work Space

- NOTES:
1. TABLE POSITION(S) AT MAX X & Y TRAVELS.
2. MEASUREMENTS ARE FROM THE EDGE OF MILL TABLE TO NEAREST OBSTRUCTION (ie. ENCLOSURE, WAY COVER, DOORS, ETC.).
3. DIMENSIONS ARE REDUCED AS HEIGHT ABOVE TABLE INCREASES; ie. FRONT OF ENCLOSURE IS SLOPED 5° INWARD FROM BOTTOM TO TOP. DIMENSIONS SHOWN ARE AT TABLE TOP HEIGHT.