

VF-6/50 Machine Layout Drawing

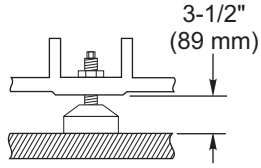

8X Leveling Pad Pin Dimension

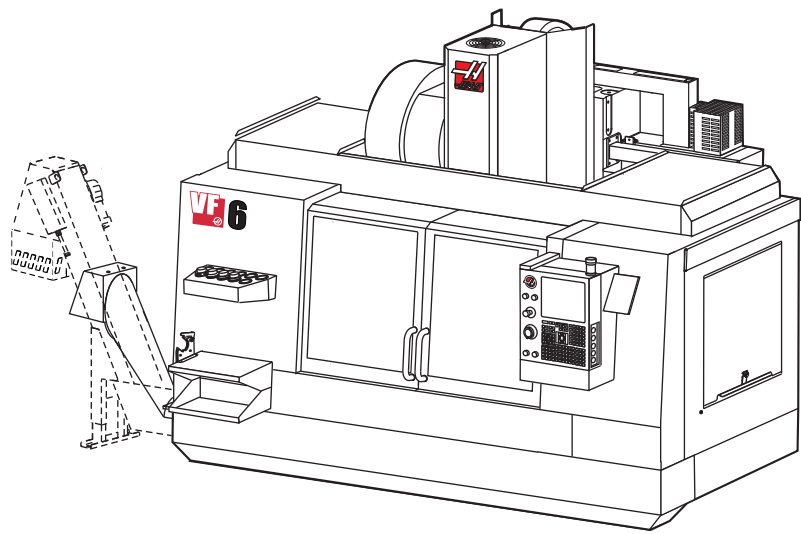

Two-Step Operator Platform included (not shown)
 Length: 72.5" (1842 mm)
 Width: 23.5" (570 mm)
 Height: 12.5" (318 mm)

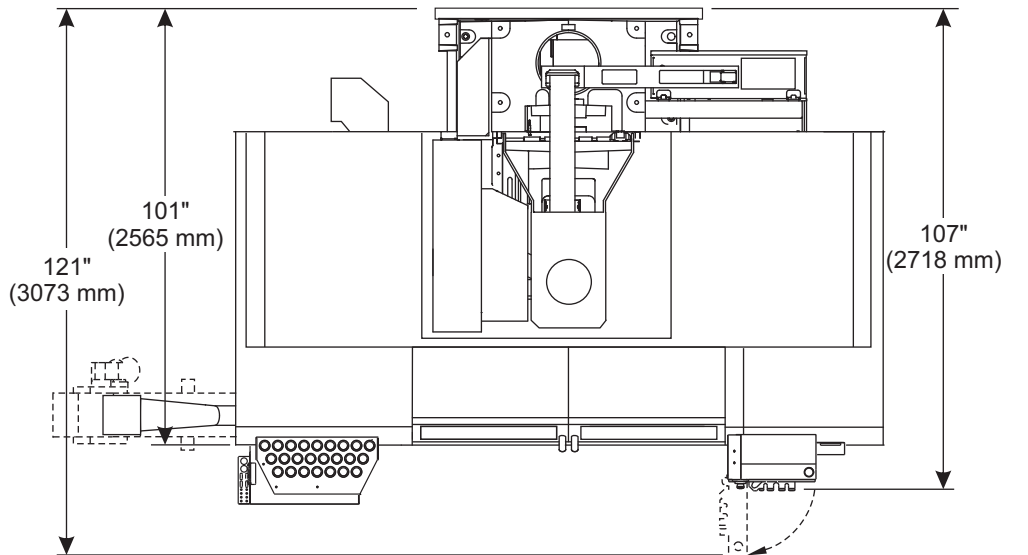

** Extended Z-Axis Clearance Option
 add 8" (203 mm)

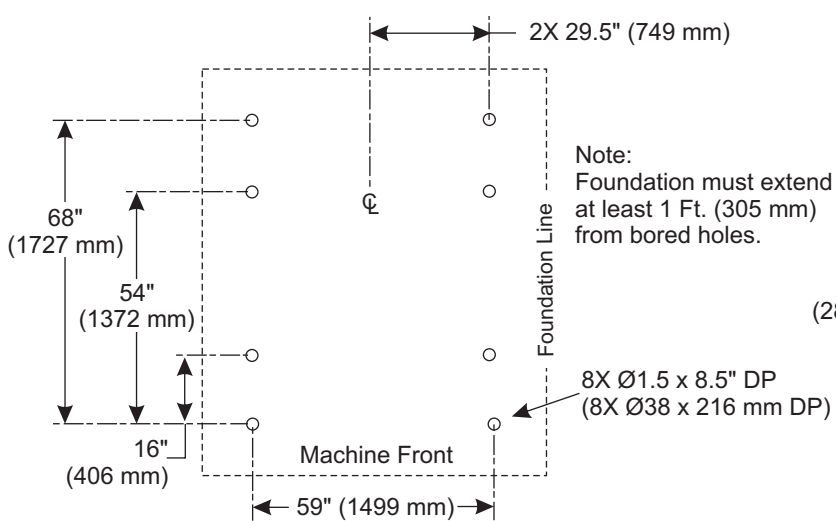
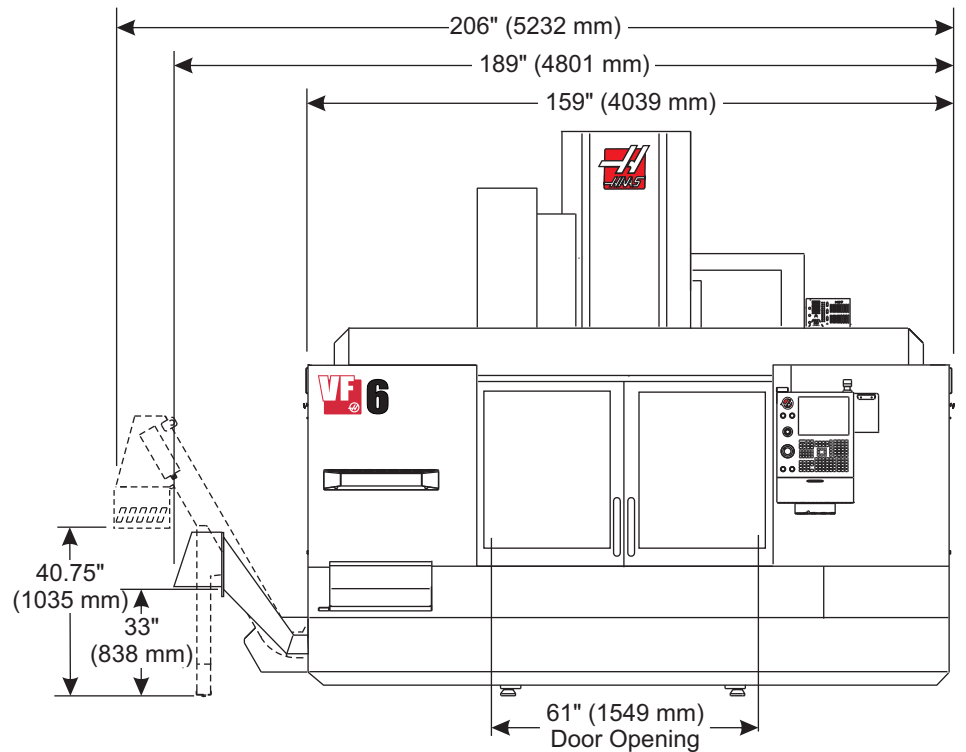
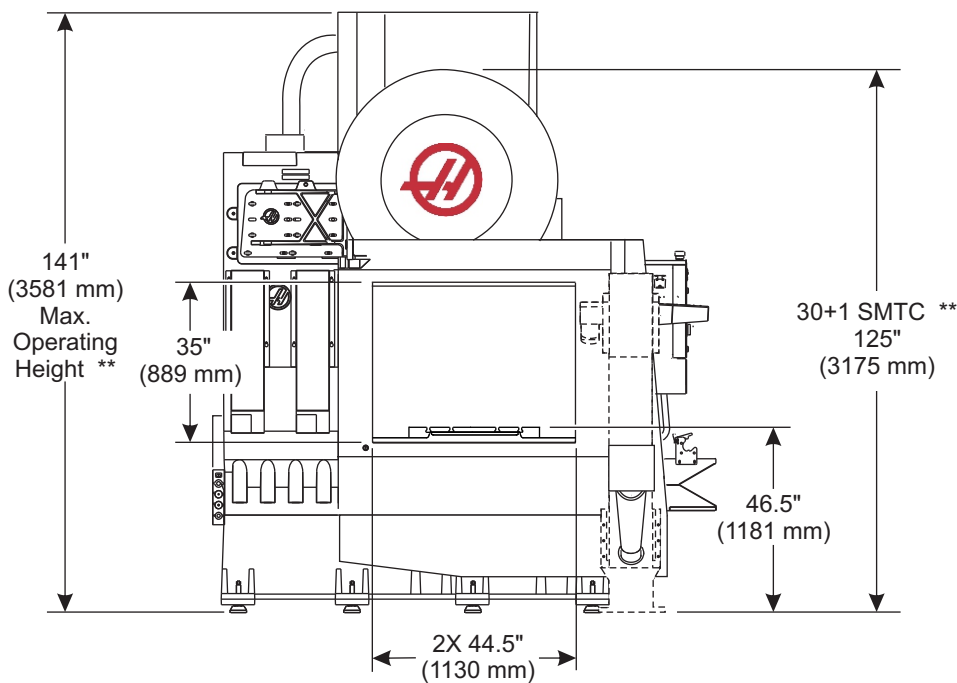

VF-6 Anchor Pattern

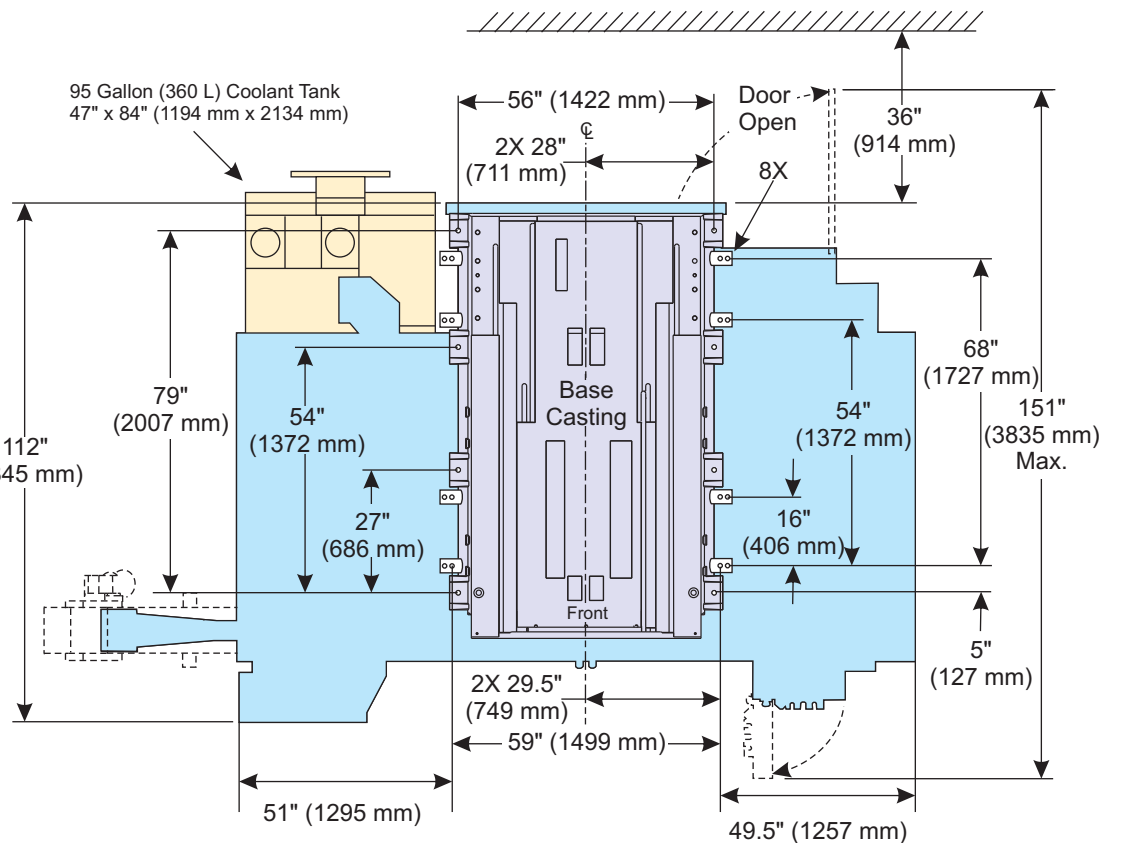

VF-6/50 Machine Layout Drawing

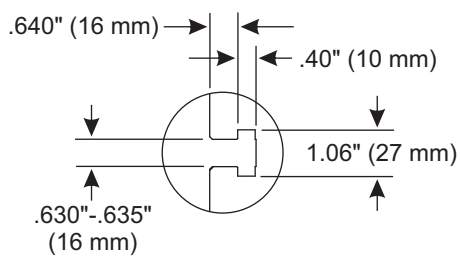
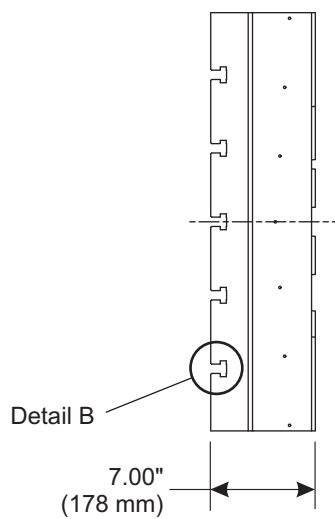
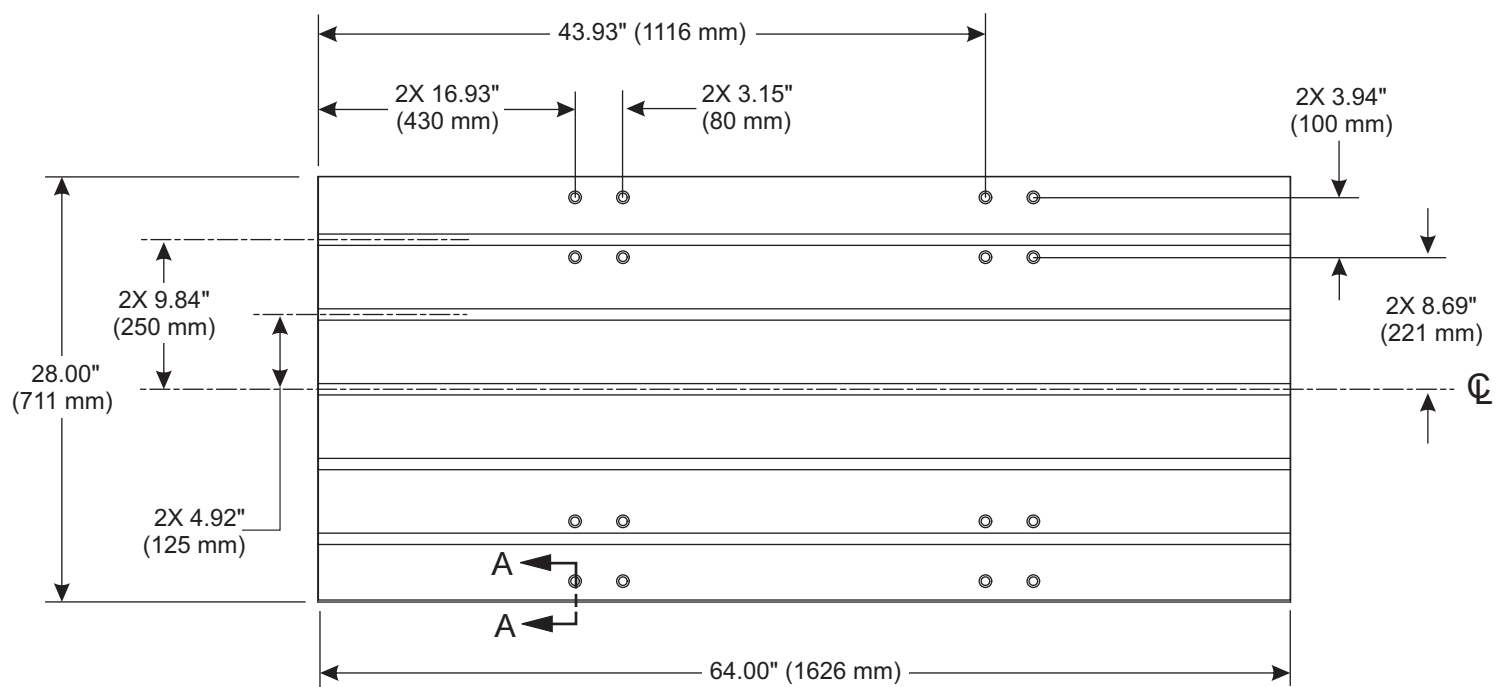

Detail B (5X)

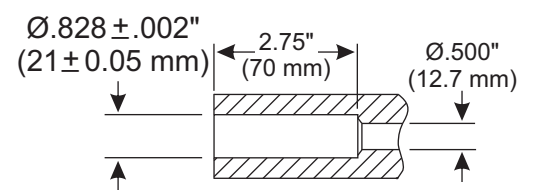

Section A-A (16X)

VF-6 Table Dimensions

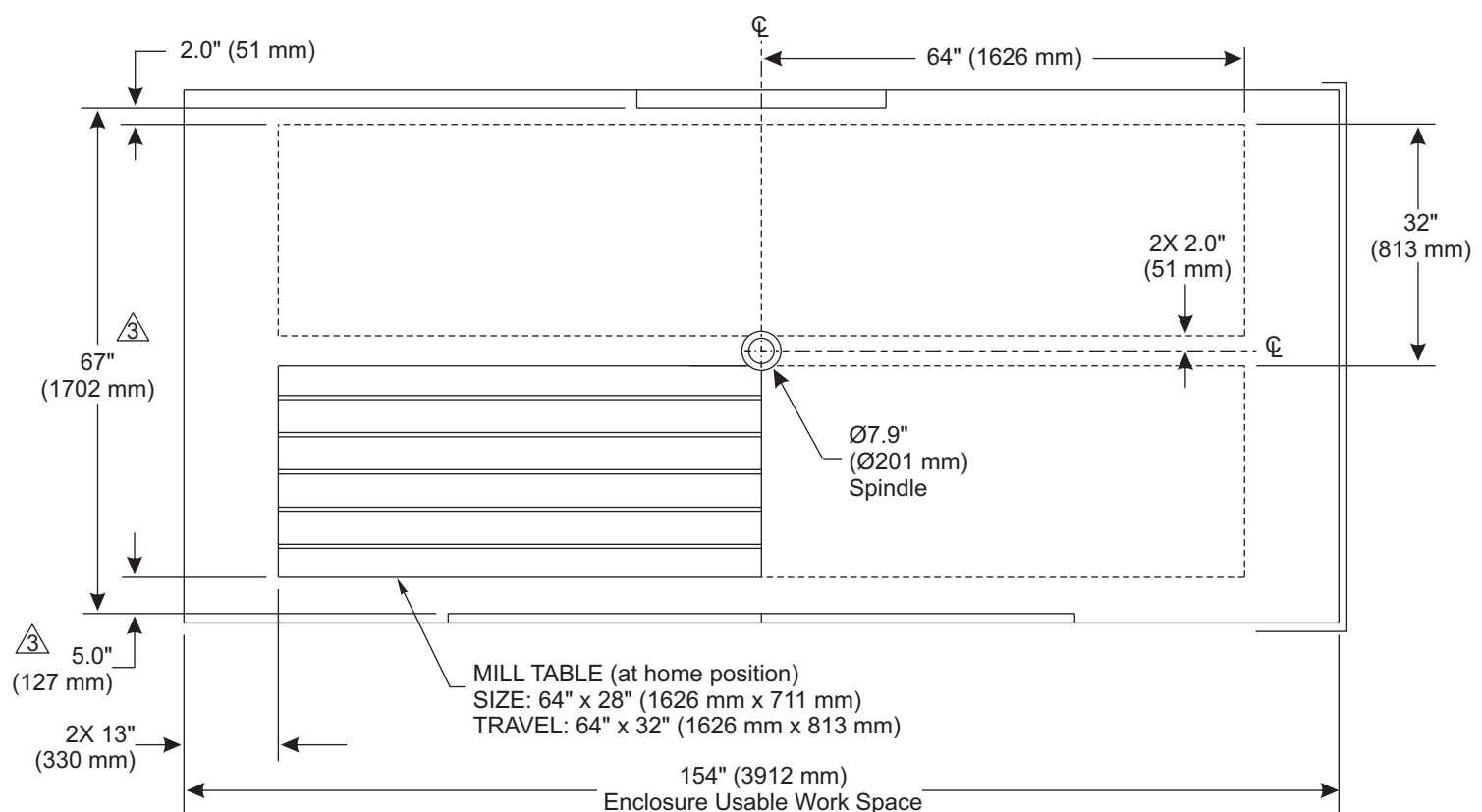

NOTES:

1. TABLE POSITION(S) AT MAX X & Y TRAVELS.
2. MEASUREMENTS ARE FROM THE EDGE OF MILL TABLE TO NEAREST OBSTRUCTION (ie. ENCLOSURE, WAY COVER, DOORS, ETC.).
3. DIMENSIONS ARE REDUCED AS HEIGHT ABOVE TABLE INCREASES; ie. FRONT OF ENCLOSURE IS SLOPED 5° INWARD FROM BOTTOM TO TOP. DIMENSIONS SHOWN ARE AT TABLE TOP HEIGHT.

Top View VF-6 Enclosure Usable Work Space

VF-6/50 Machine Layout Drawing

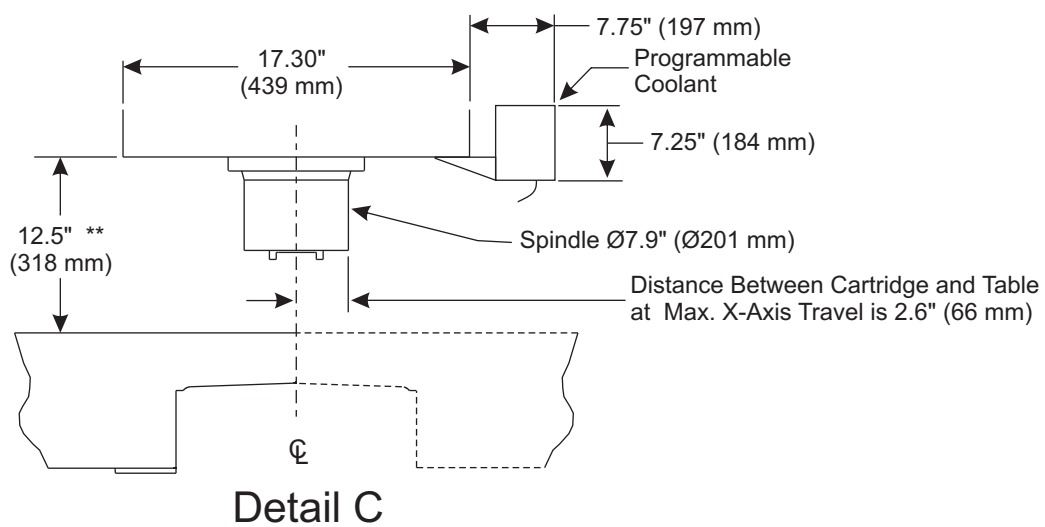
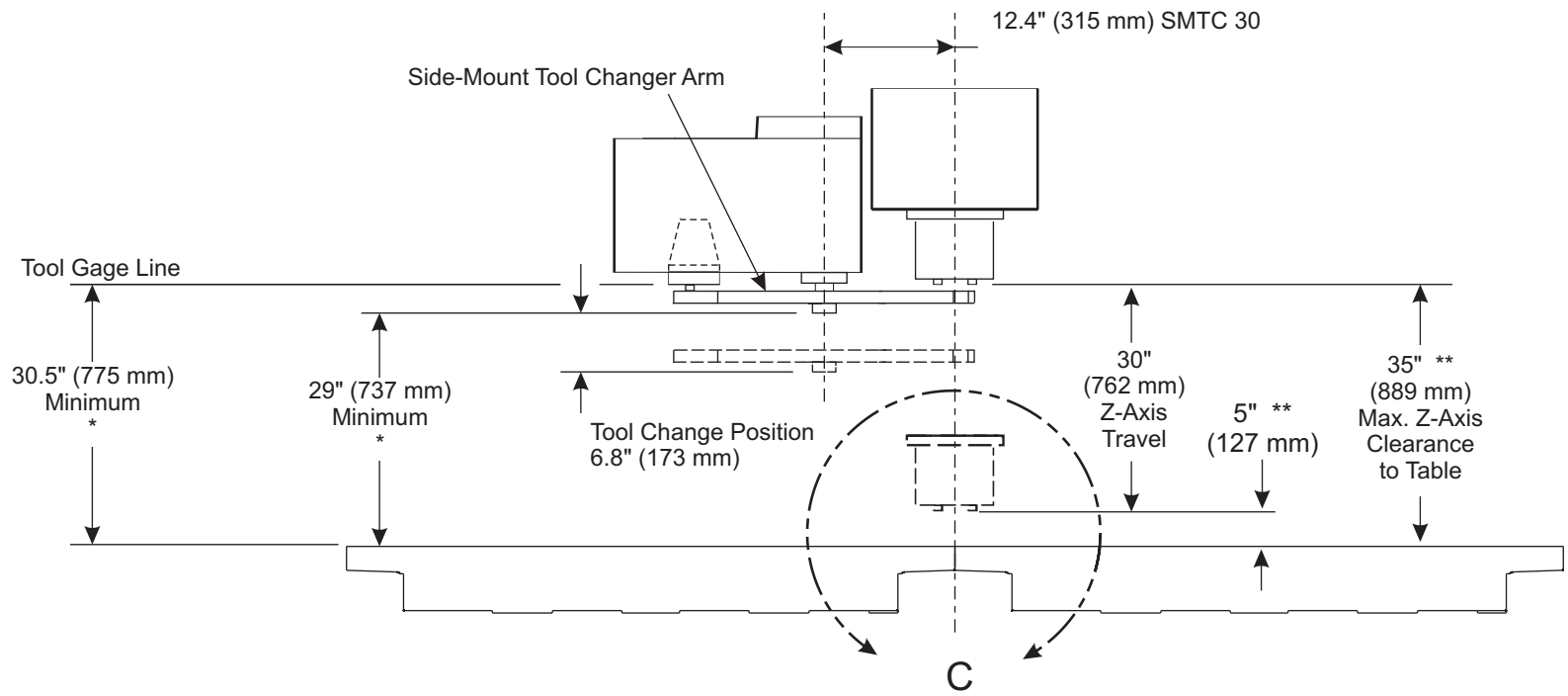

Front View

VF-6 Enclosure Usable Work Space