

VF-6 Anchor Pattern

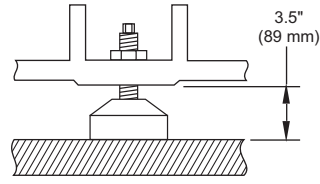

Leveling Pad Pin Dimension

Reference ES0039  
Machine Clearance Heights

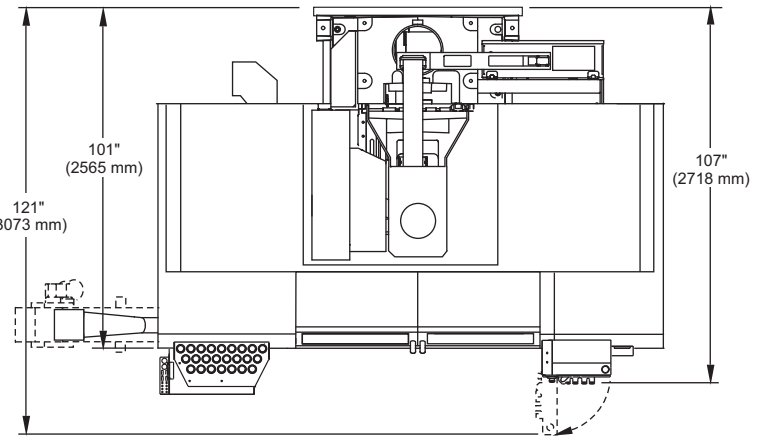

Two-Step Operator Platform included (not shown)  
Length: 72.5" (1842 mm)  
Width: 23.5" (570 mm)  
Height: 12.5" (318 mm)

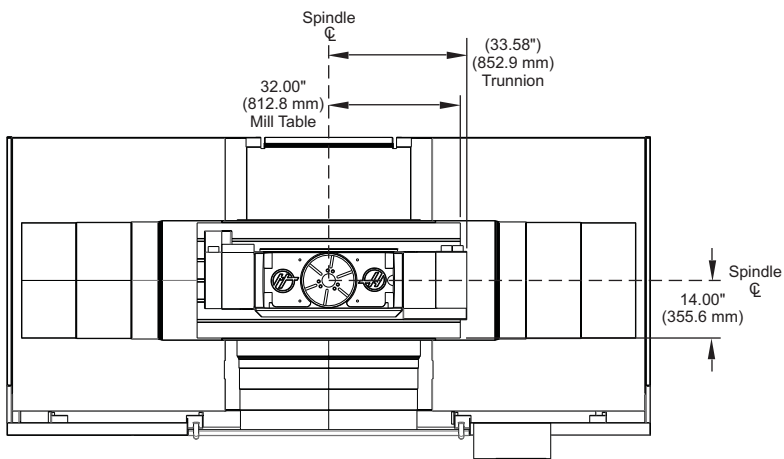
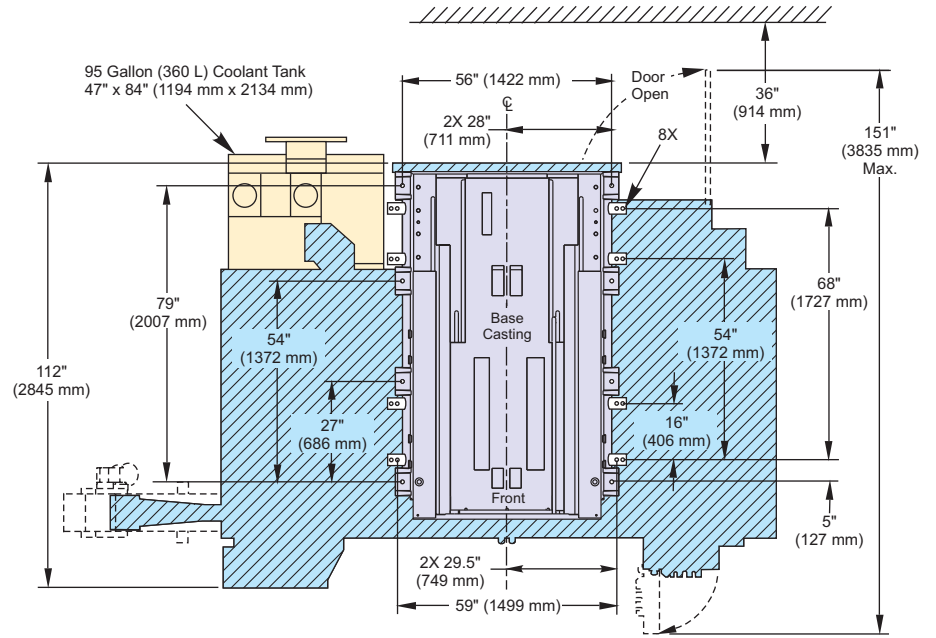
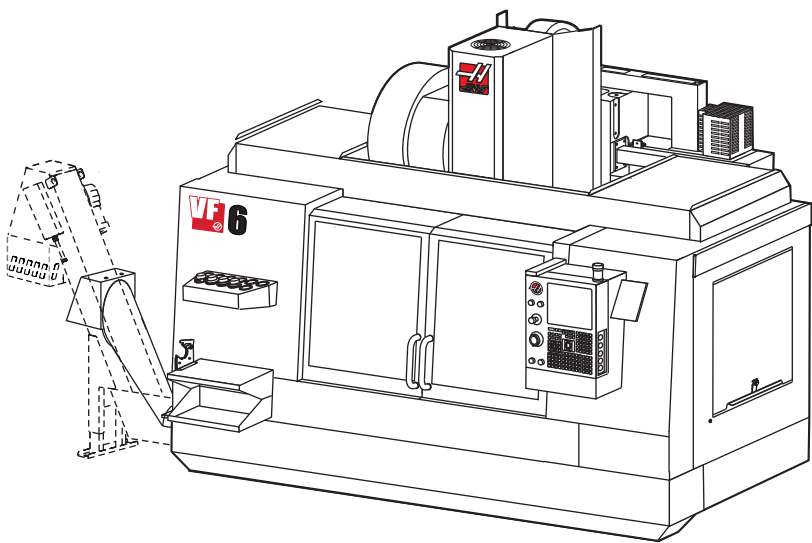
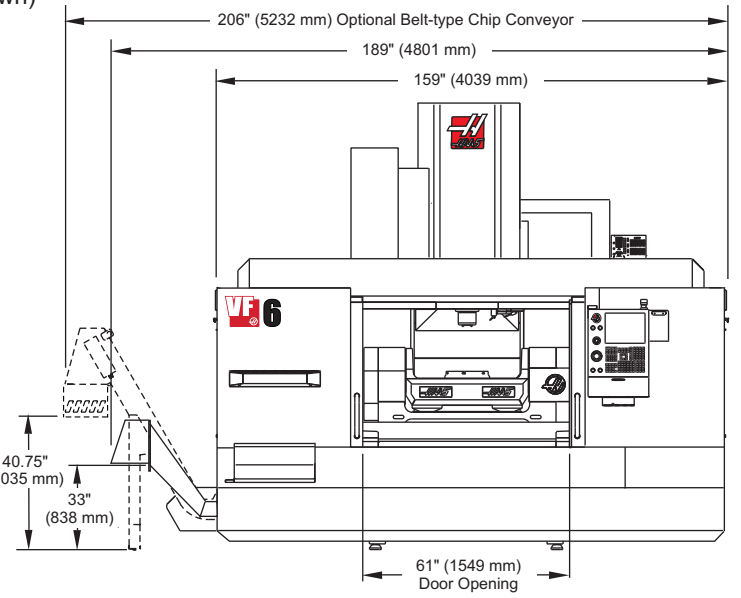
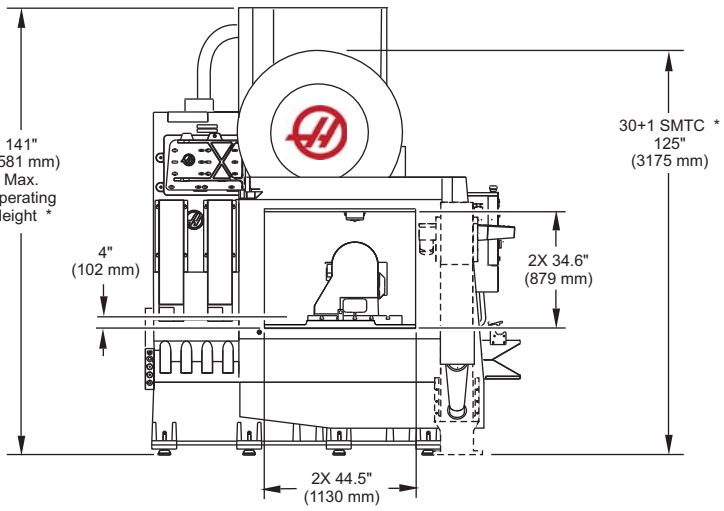

TOP VIEW

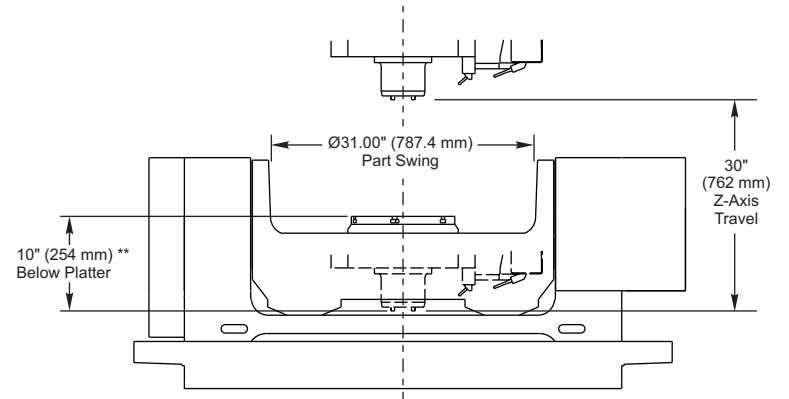

FRONT VIEW

For detailed VF-6 table dimensions, see the VF-6/50 layout drawing.

For detailed TR310 dimensions, see the TR310 layout drawing.

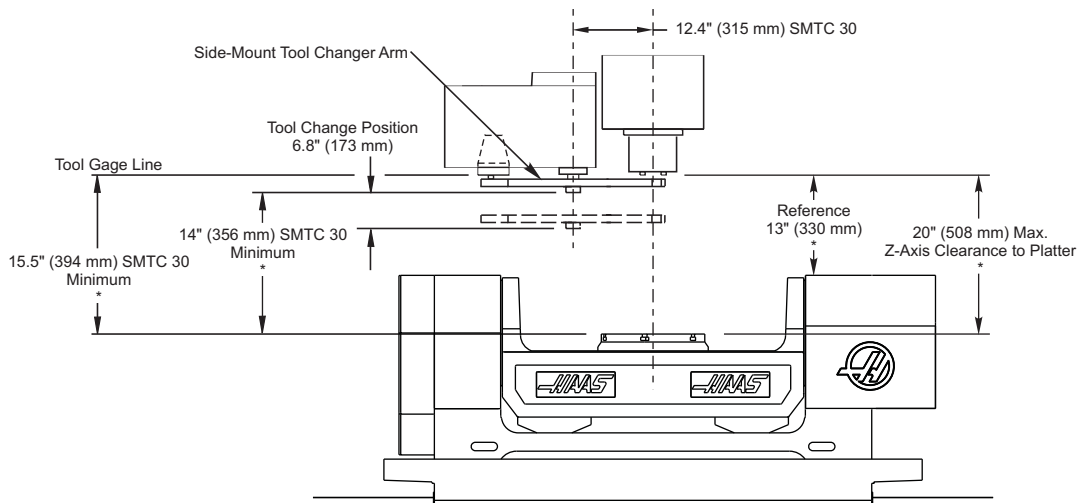

\* Add 8" (203 mm) for Extended Z-Axis Clearance Option  
\*\* Subtract 8" (203 mm) for Extended Z-Axis Clearance Option