

Standard Tool Changer:
20 Station Umbrella Tool Changer
30+1 Station Side-Mount Tool Changer
50+1 Station Side-Mount Tool Changer

Operating Dimensions

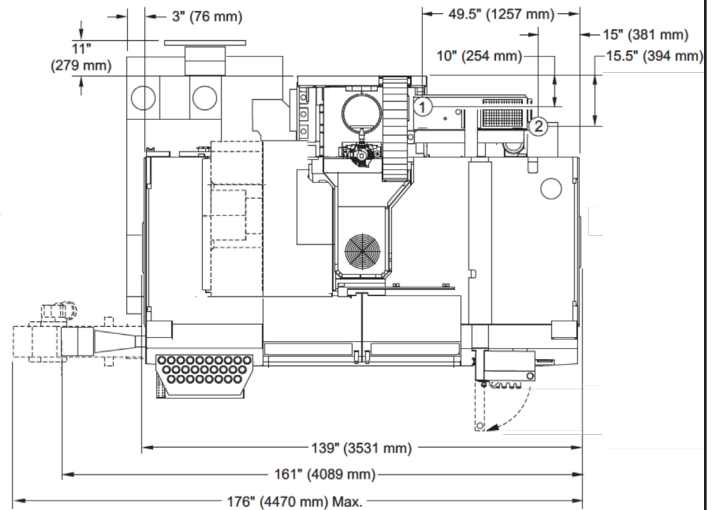
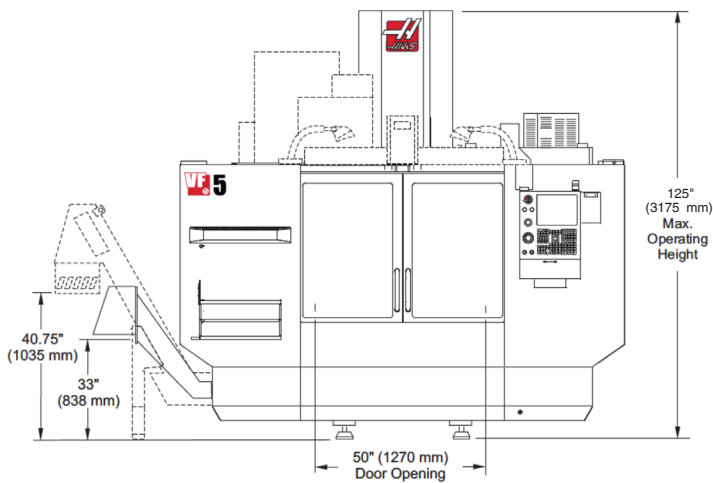

- ① Electrical Connection
- ② Air Connection

Option: Multi-Auger Chip Conveyor

Minimum distance required to remove conveyor from mill is 85in (2159mm) without folding the conveyor.

Minimum distance required to remove conveyor is 50in (1270mm) when the conveyor is folded at 90 degrees and folded down as if removed.

Breakdown Height

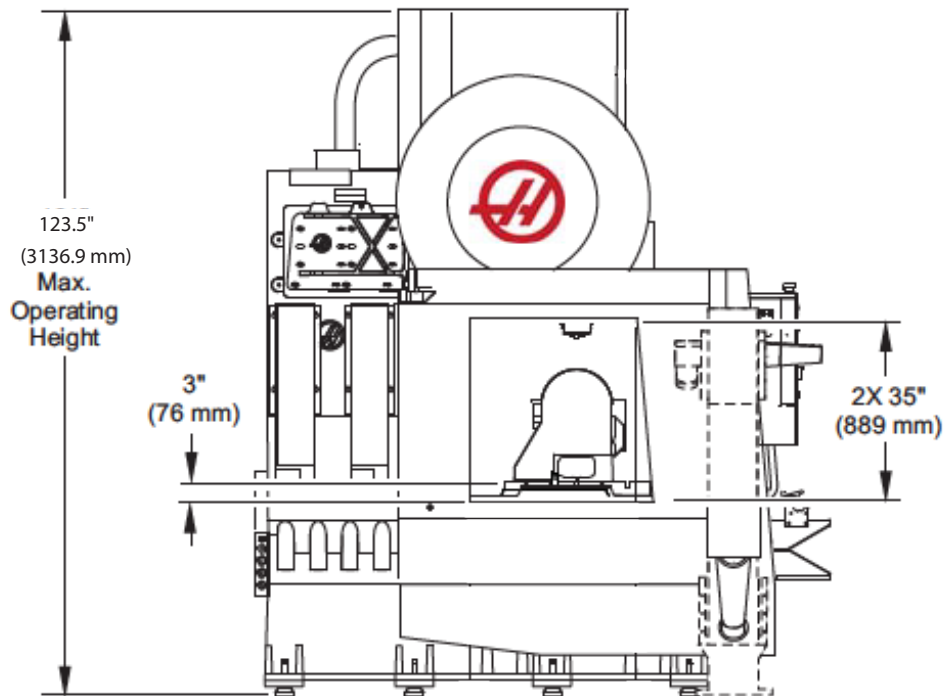

*Due to continual product improvements, machine dimensions are subject to change without notice.

X/Y Axis Clearances

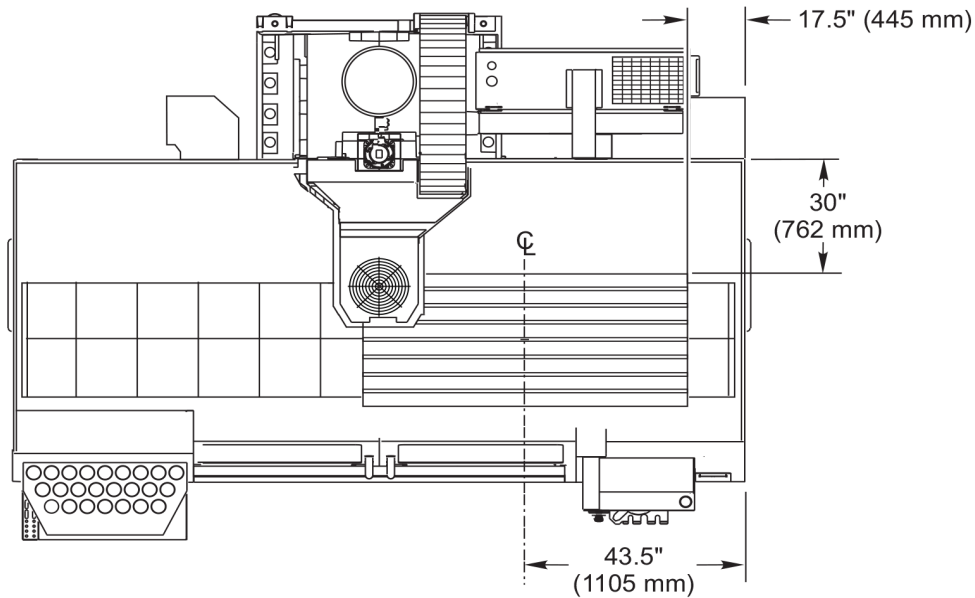

Notes:

1. The table shown is at XY home, the dashed is the table at max XY travels.
2. Measurements are from the edge of the table to the nearest obstruction.
3. Dimensions shown are at the top of the table. Dimensions are reduced as the height increased (5 degree slope inside the sheet metal).
4. Dimensions are symmetrical unless otherwise stated.

Z Axis Clearances

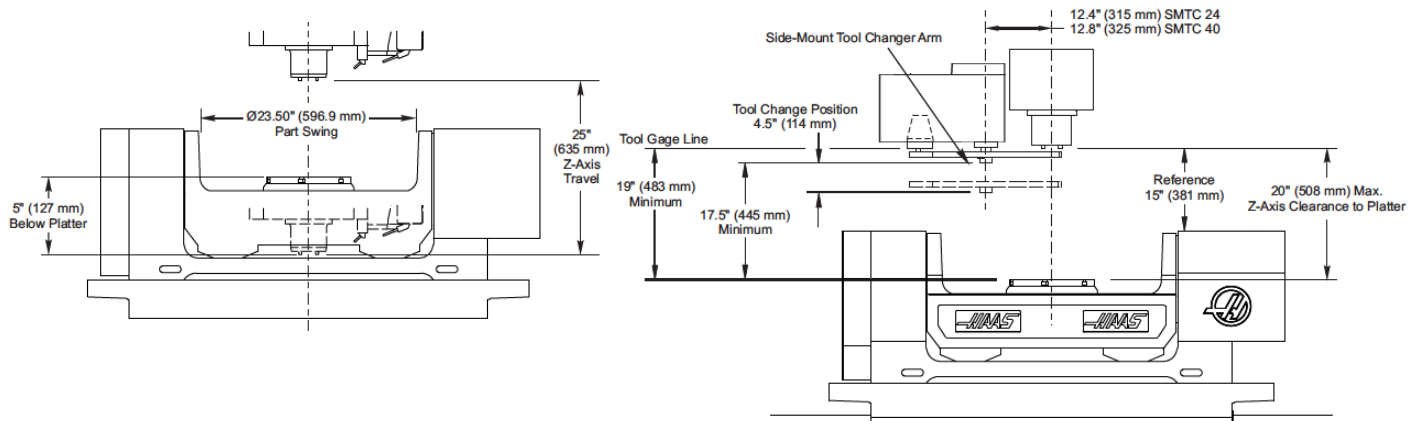

Notes:

1. The low-profile tables are 3 in(76mm) lower than the standard table.
2. P-COOL dimension varies based on P-COOL position.
3. Refer to the page on Tool Changer Dimensions for tool changer heights.

