

VF-5 Anchor Pattern

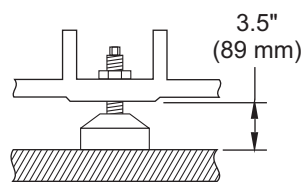

Leveling Pad Pin Dimension

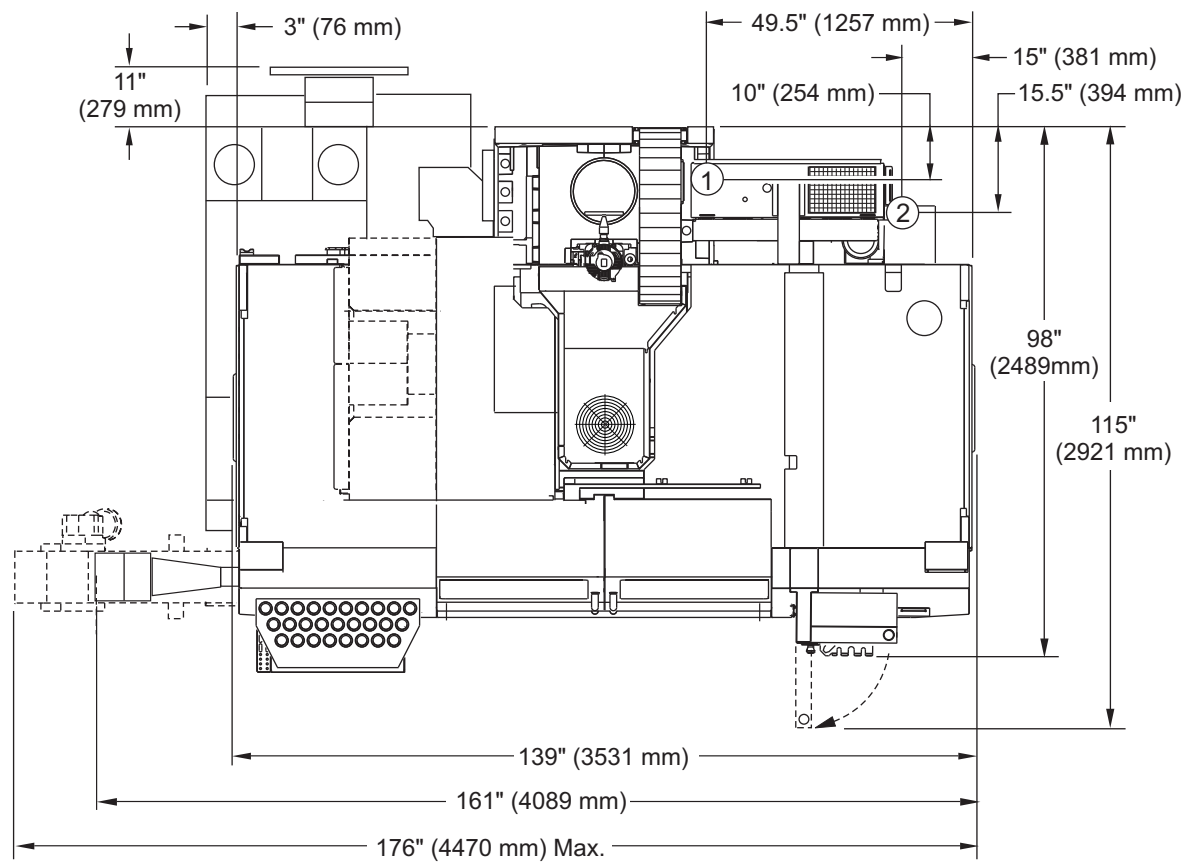

- ① Electrical Connection
- ② Air Connection

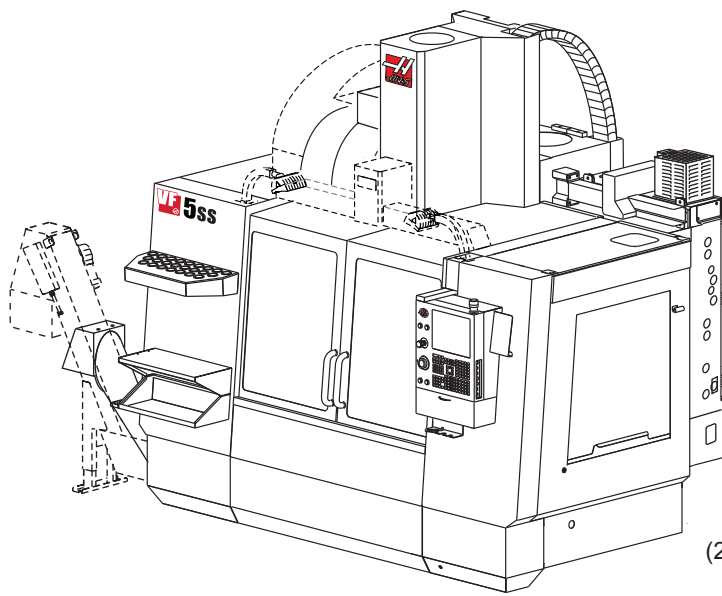

Standard: 24+1 Side Mount Tool Changer  
 Option: 40+1 Side Mount Tool Changer

Reference ES0039  
 Machine Clearance Heights

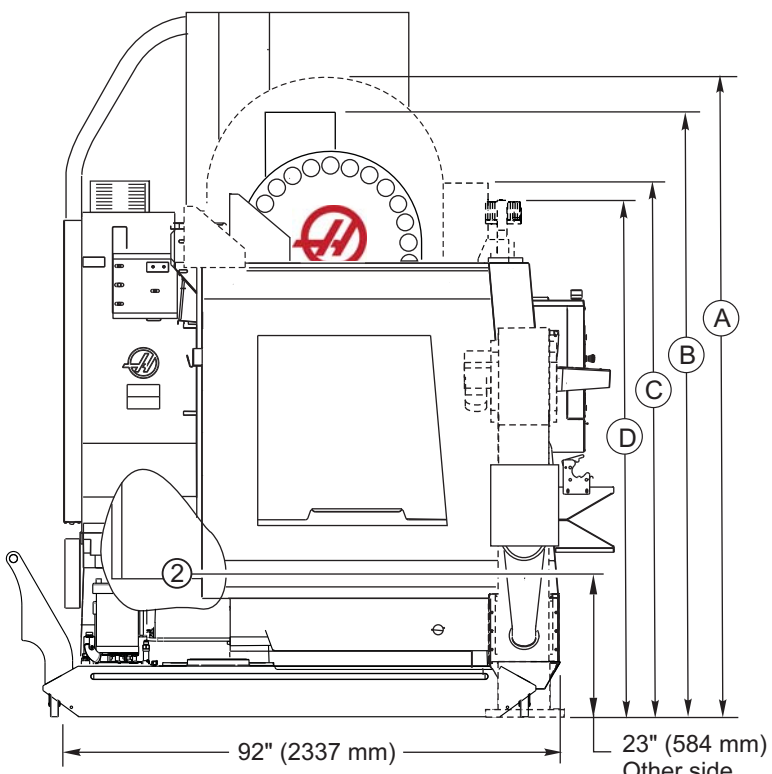
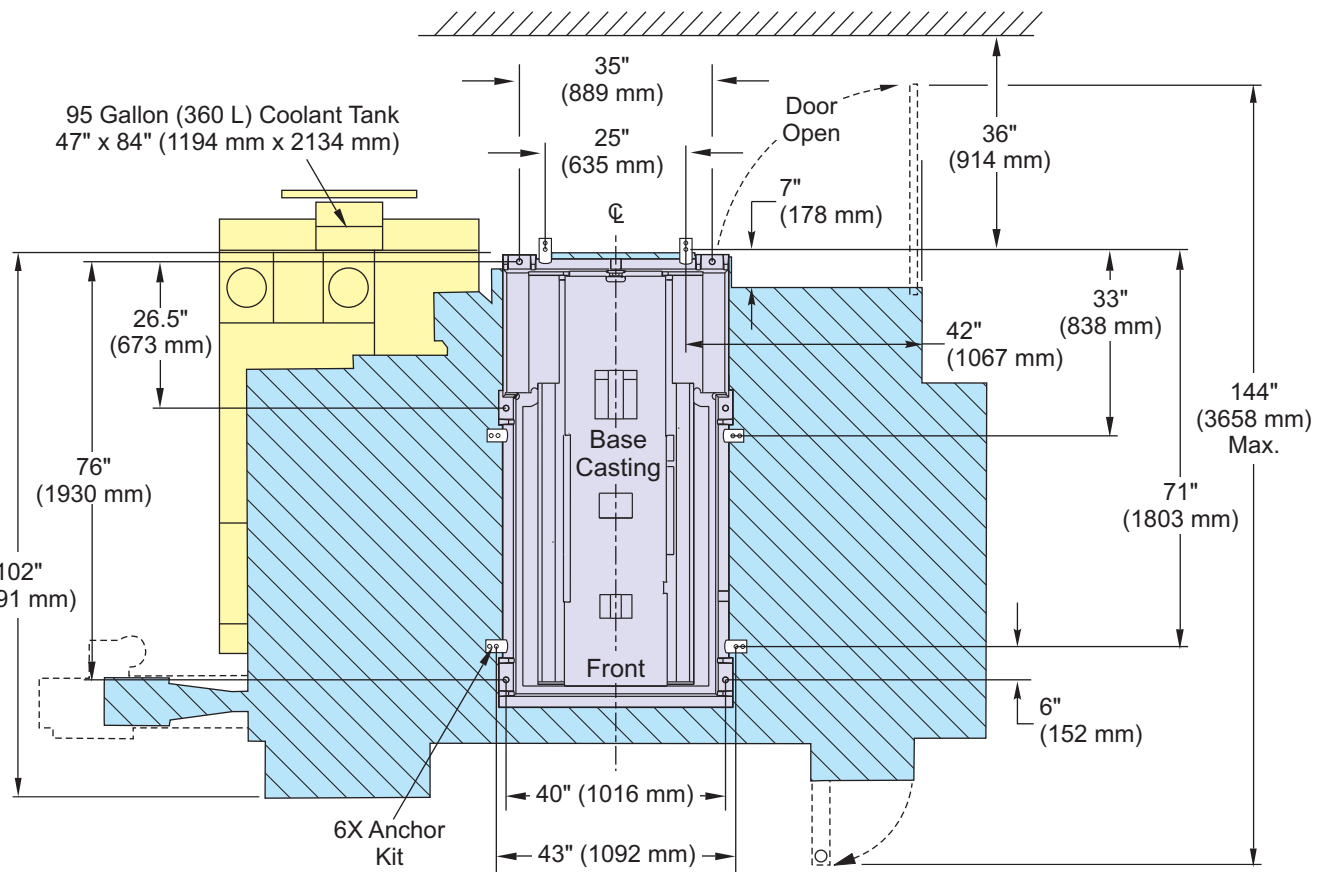

A	115" (2921 mm) SMTC 40 Optional
B	107" (2718 mm) SMTC 24
C	95" (2413 mm) Auto Door Optional
D	92" (2337 mm) High Intensity Lights Optional

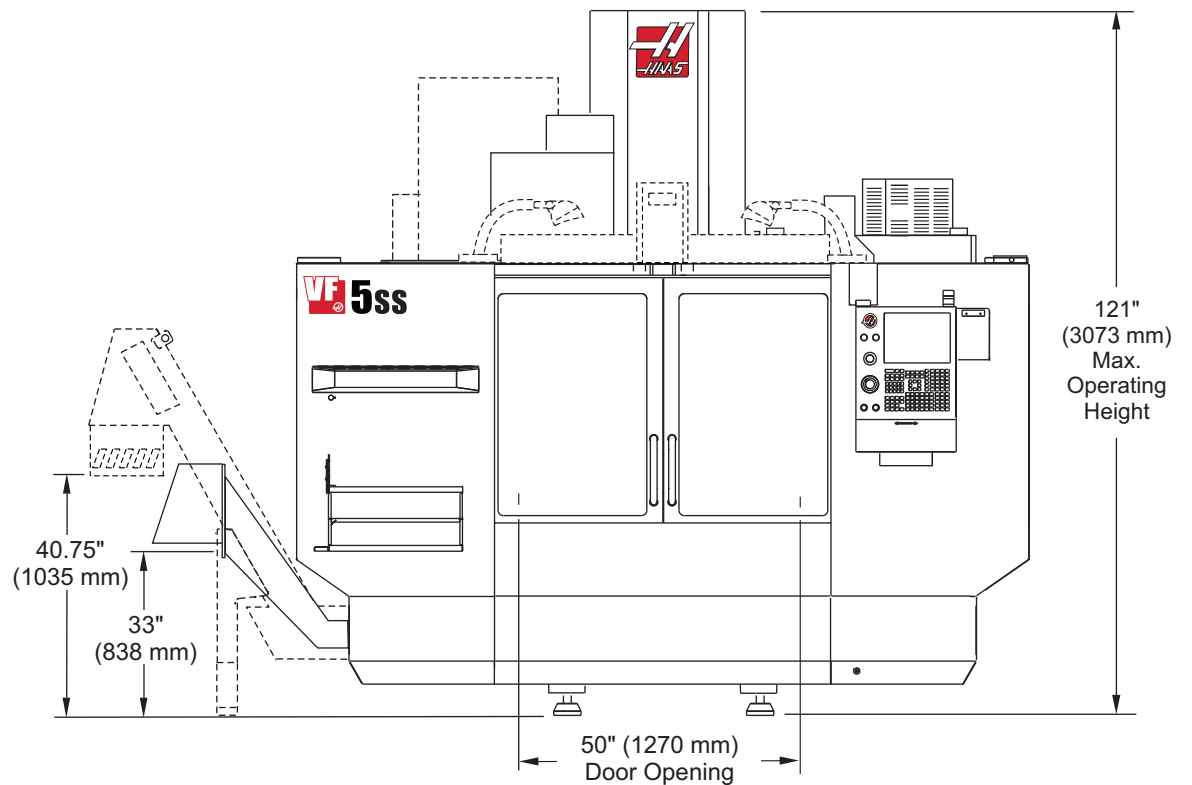

Option: Multi-Auger Chip Conveyor

Minimum distance required to remove conveyor from mill 85" (2159 mm).

Minimum distance required to remove conveyor from mill 50" (1270 mm) when conveyor is folded at 90 degrees and folded down as it is pulled out.

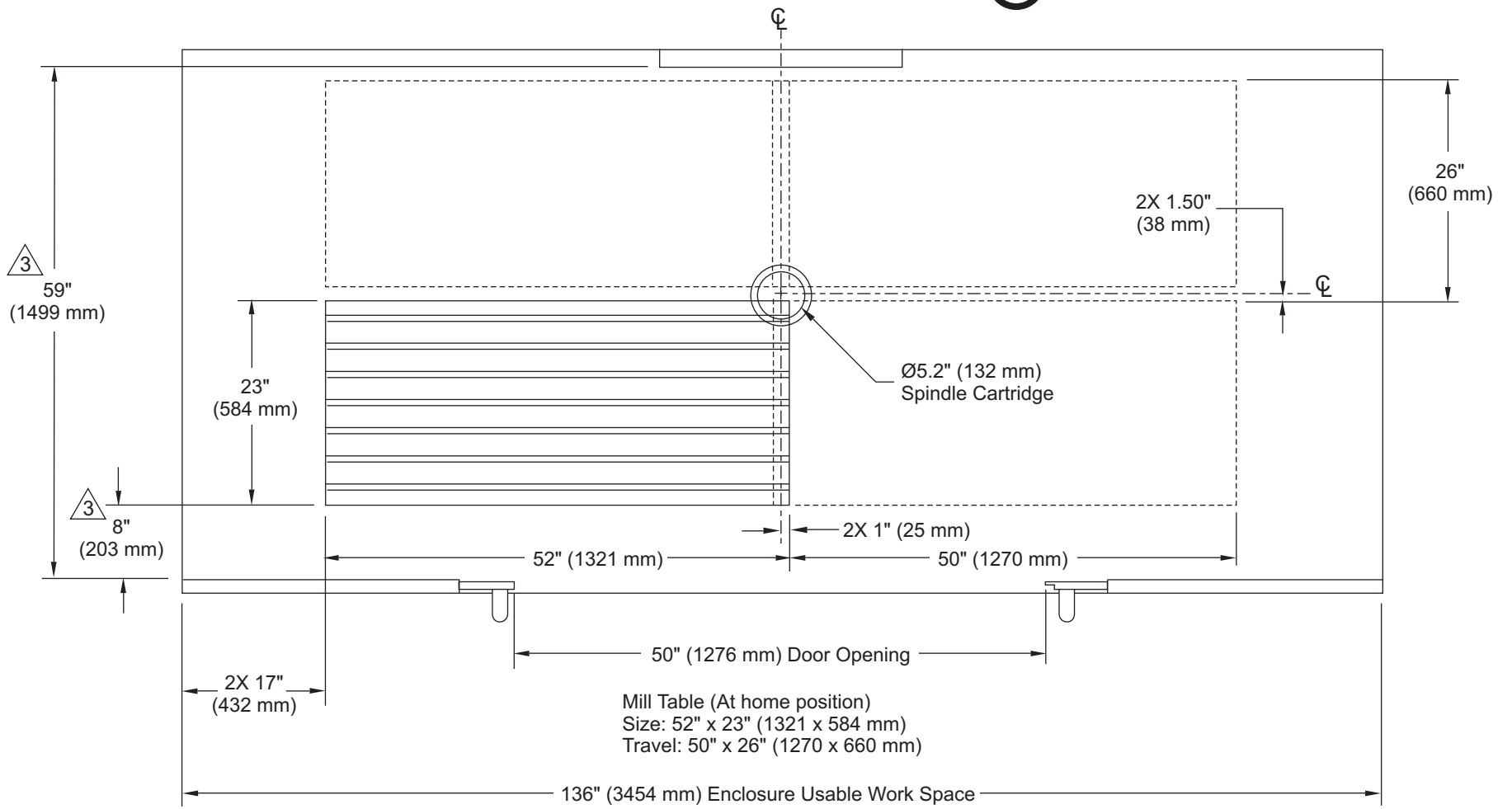

- Notes: 1. Table position(s) at max X and Y travels.  
2. Measurements are from the edge of the mill table to nearest obstruction (ie, enclosure, way cover, doors, etc.).  
3. Dimensions are reduced as height above table increases; ie, front of enclosure is sloped 5 degrees inward from bottom to top. Dimensions shown are at table top height.

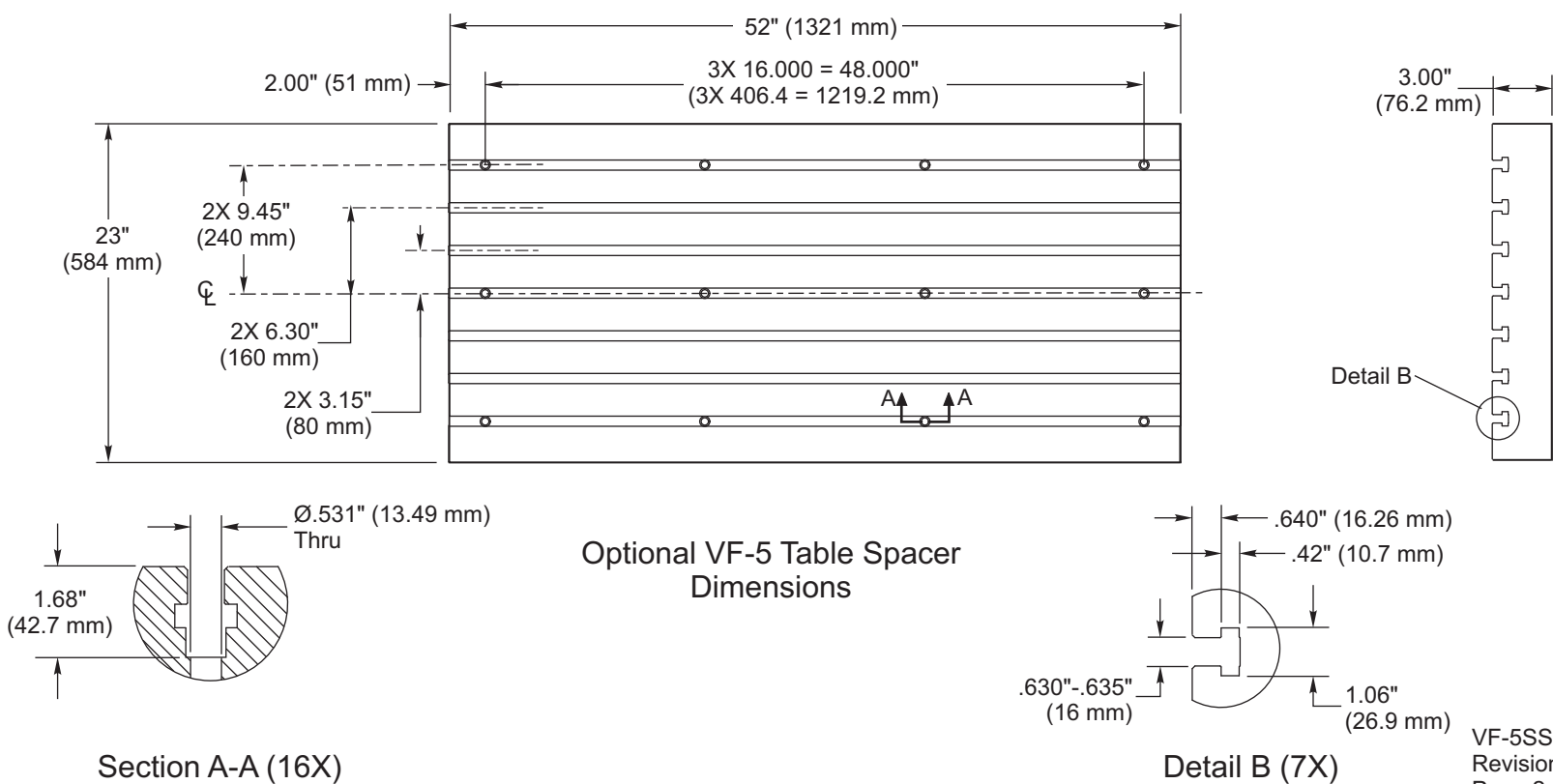
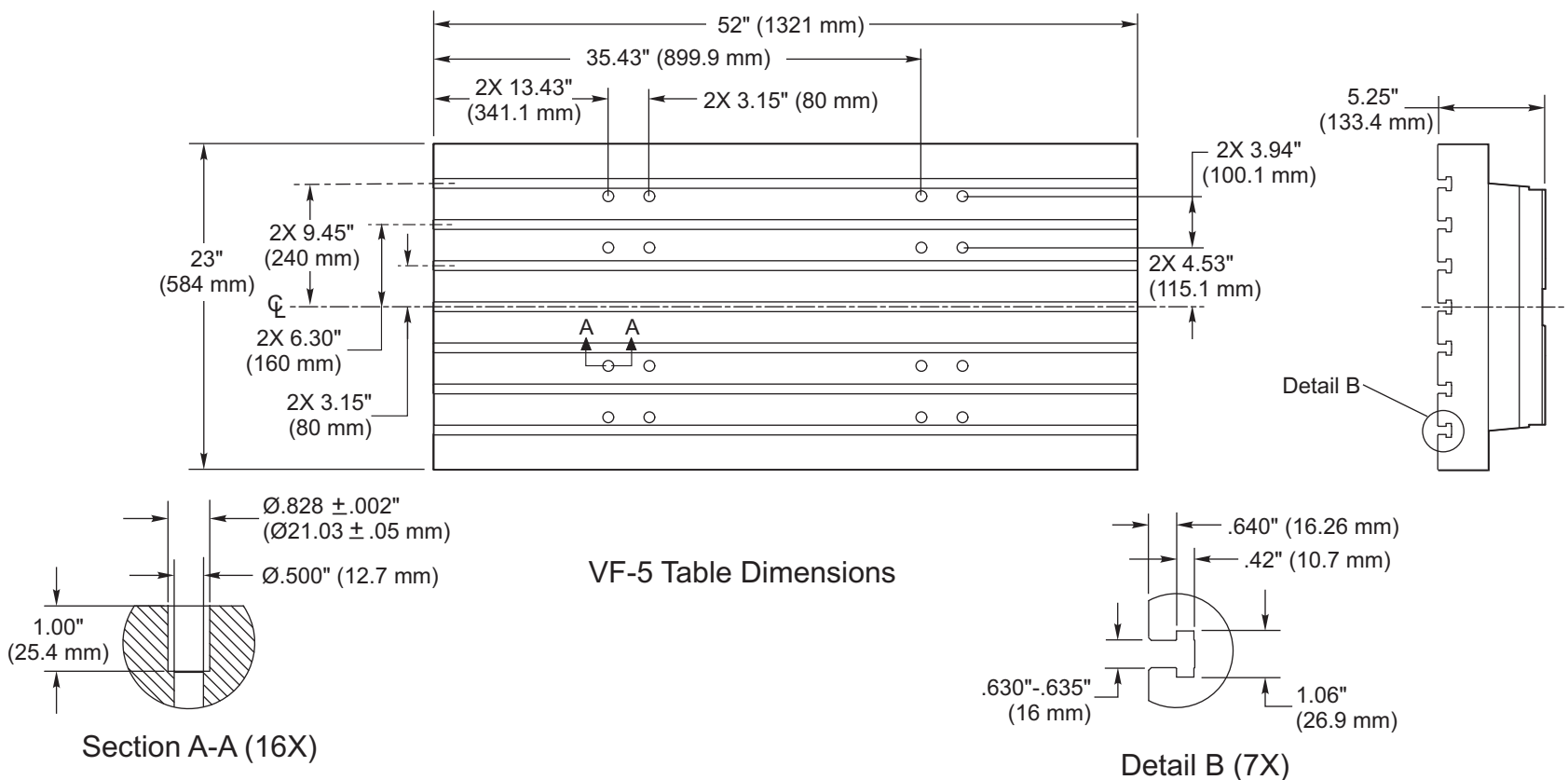



1. Double Arm drops down 4.5" (114 mm).
2. Double Arm swing diameter.
3. Overall length of arm.

A	24.1" (612 mm) 24+1 SMTC 30.2" (767 mm) 40+1 SMTC
B	20.9" (531 mm) 24+1 SMTC 27" (686 mm) 40+1 SMTC
C	2.7" (69 mm) 24+1 SMTC 4.2" (107 mm) 40+1 SMTC
D	10.1" (257 mm) 24+1 SMTC 12.8" (325 mm) SMTC

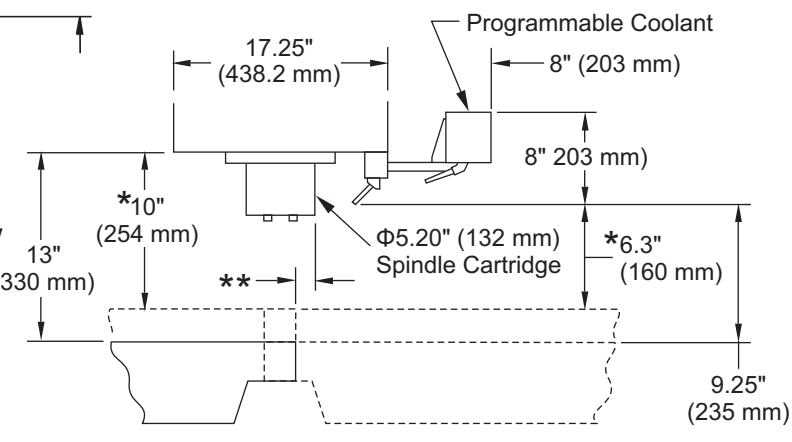
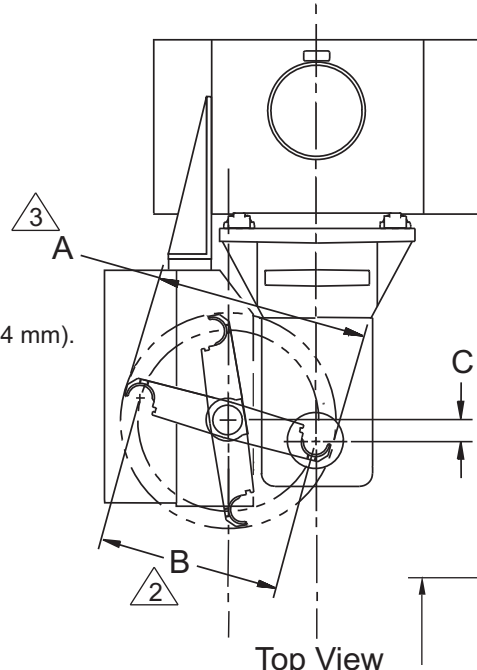

\*\* Distance Between Cartridge and Table at Max. X-Axis Travel is 1.60" (40.6 mm)

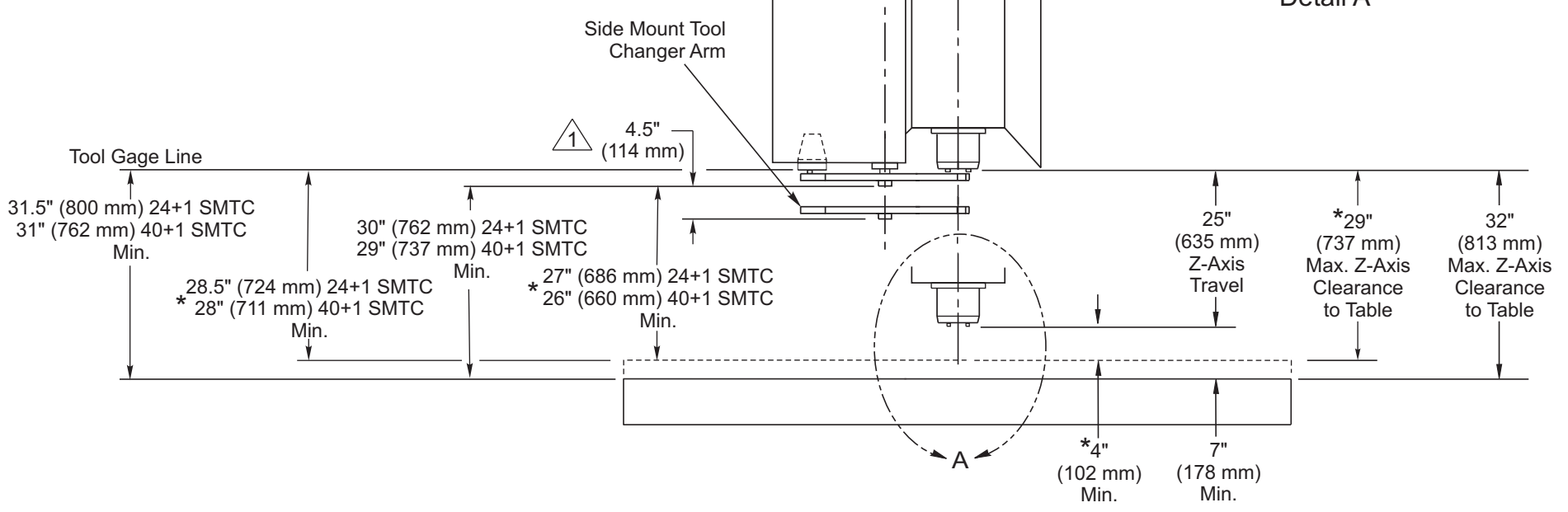

40 Taper 24+1 Side Mount Tool Changer  
40 Taper 40+1 Side Mount Tool Changer  
Double Arm Work Envelope

\*Table Spacer Optional

Front View

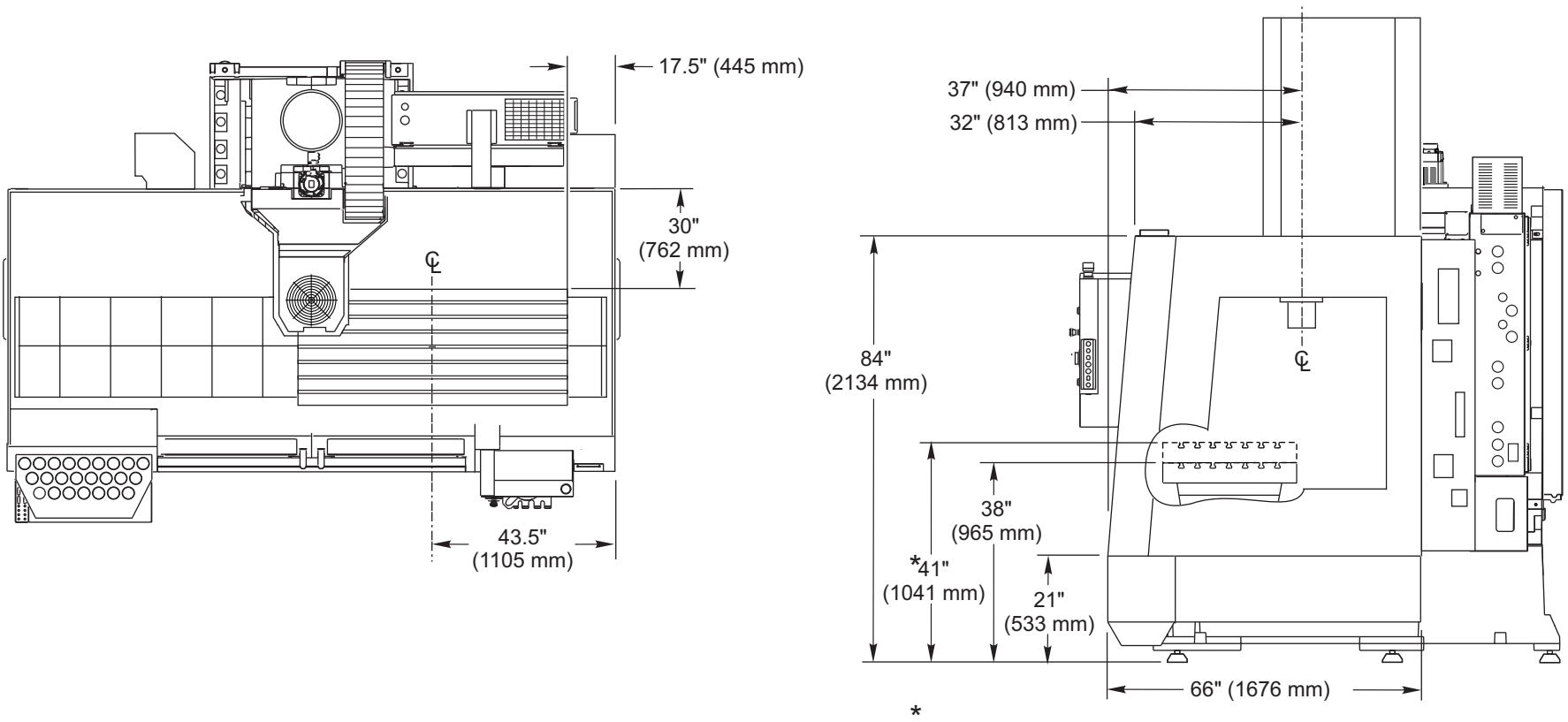

Sheet Metal Enclosure and Table to Exterior Sheet Metal Dimensions