

VF-5 Anchor Pattern

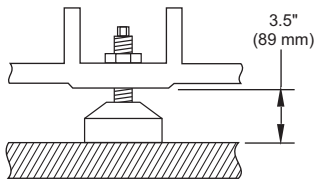

Leveling Pad Pin Dimension

Reference ES0039
Machine Clearance Heights

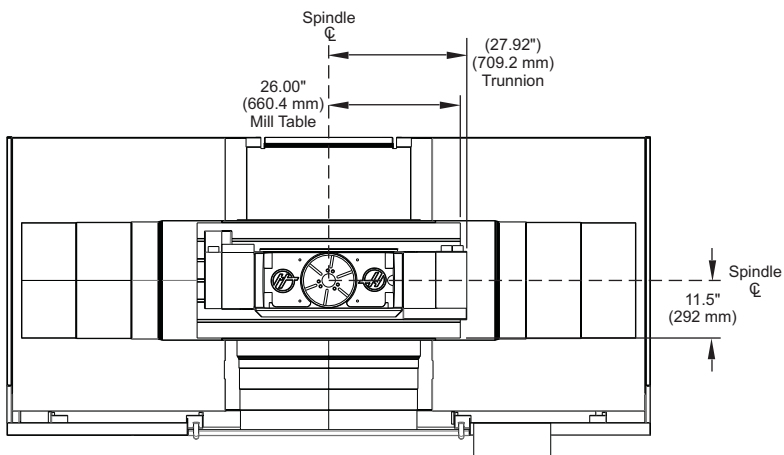
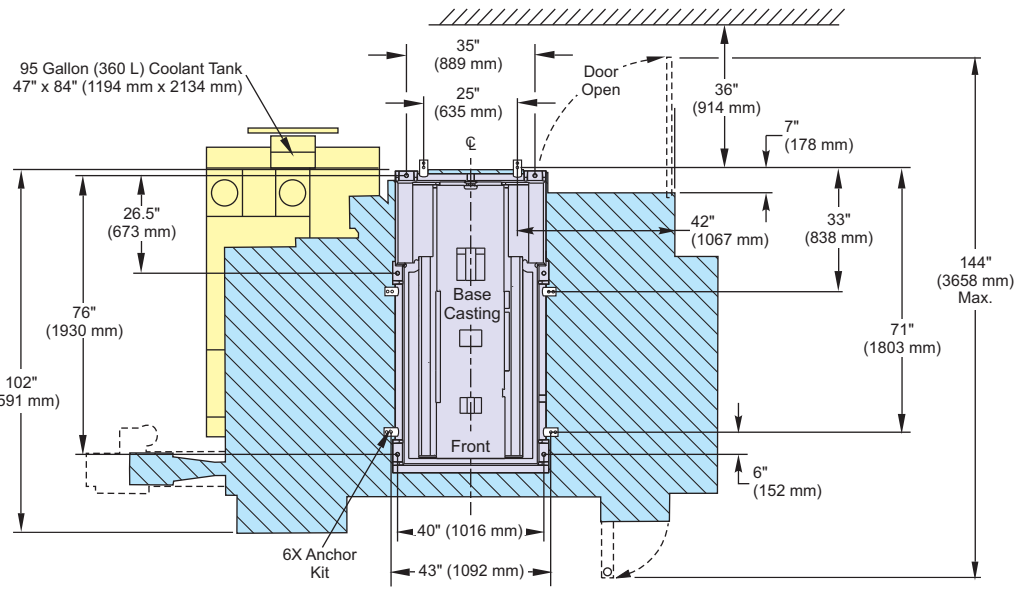
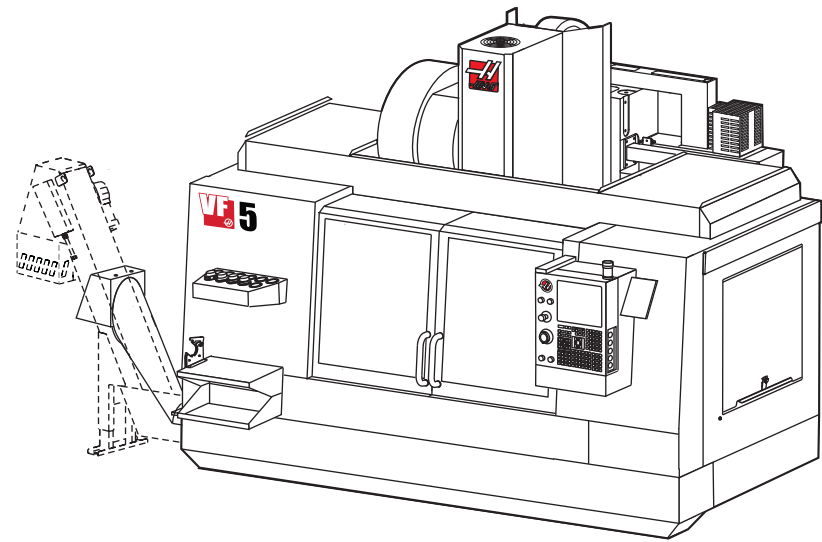
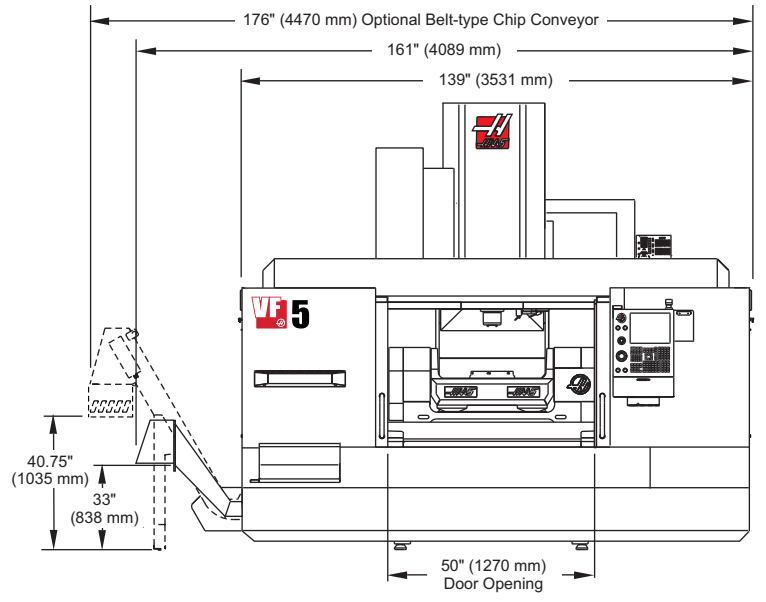
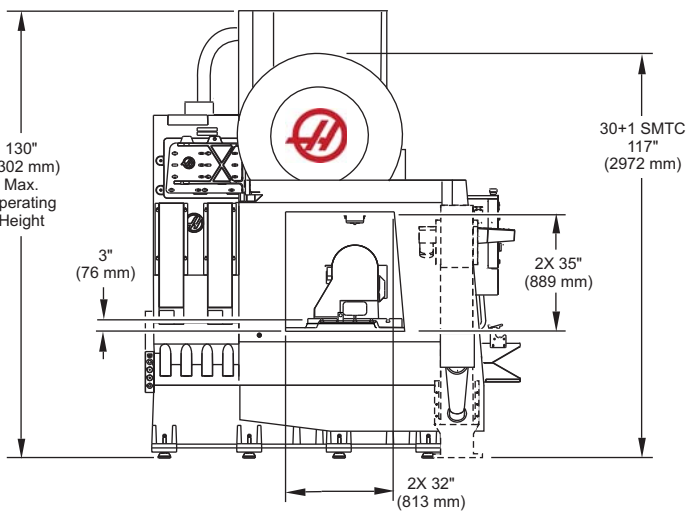
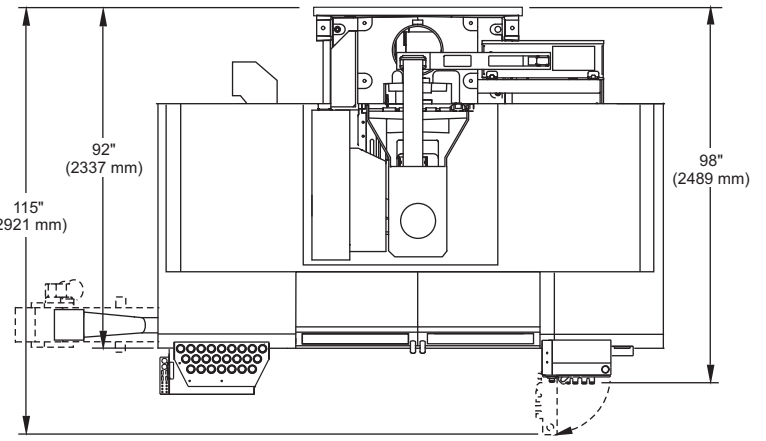

TOP VIEW

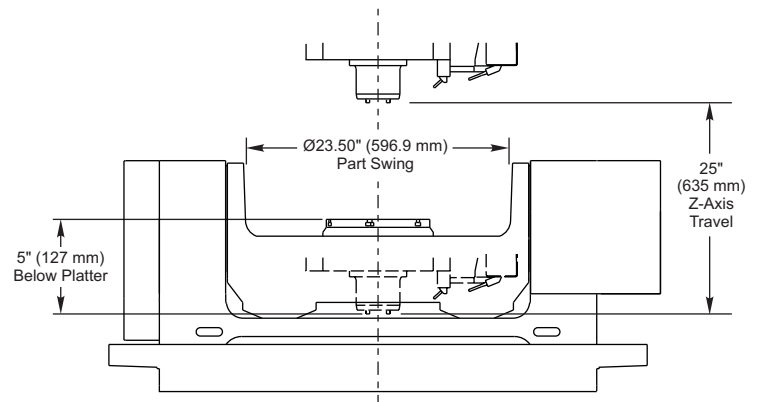

FRONT VIEW
30+1 SMTC

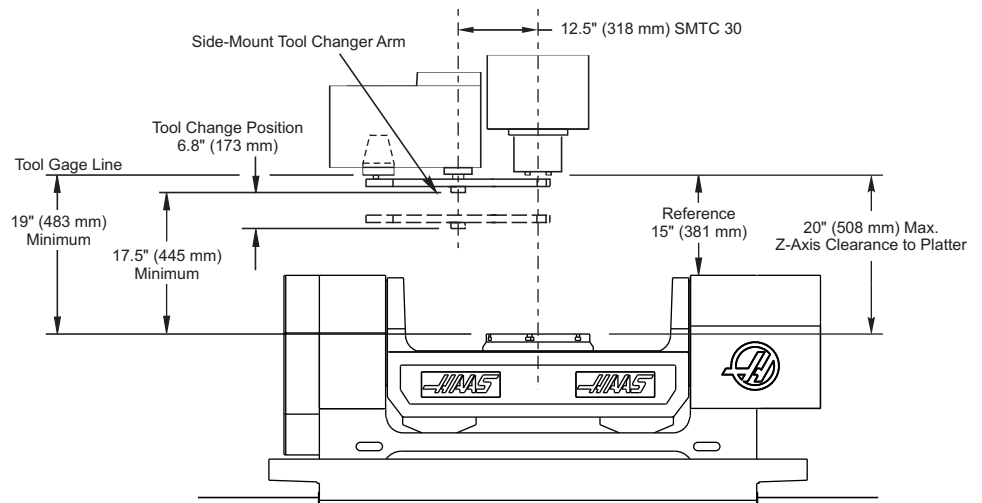

For detailed VF-5 table dimensions,
see the VF-5/50 layout drawing.

For detailed TR210 dimensions,
see the TR210 layout drawing.