

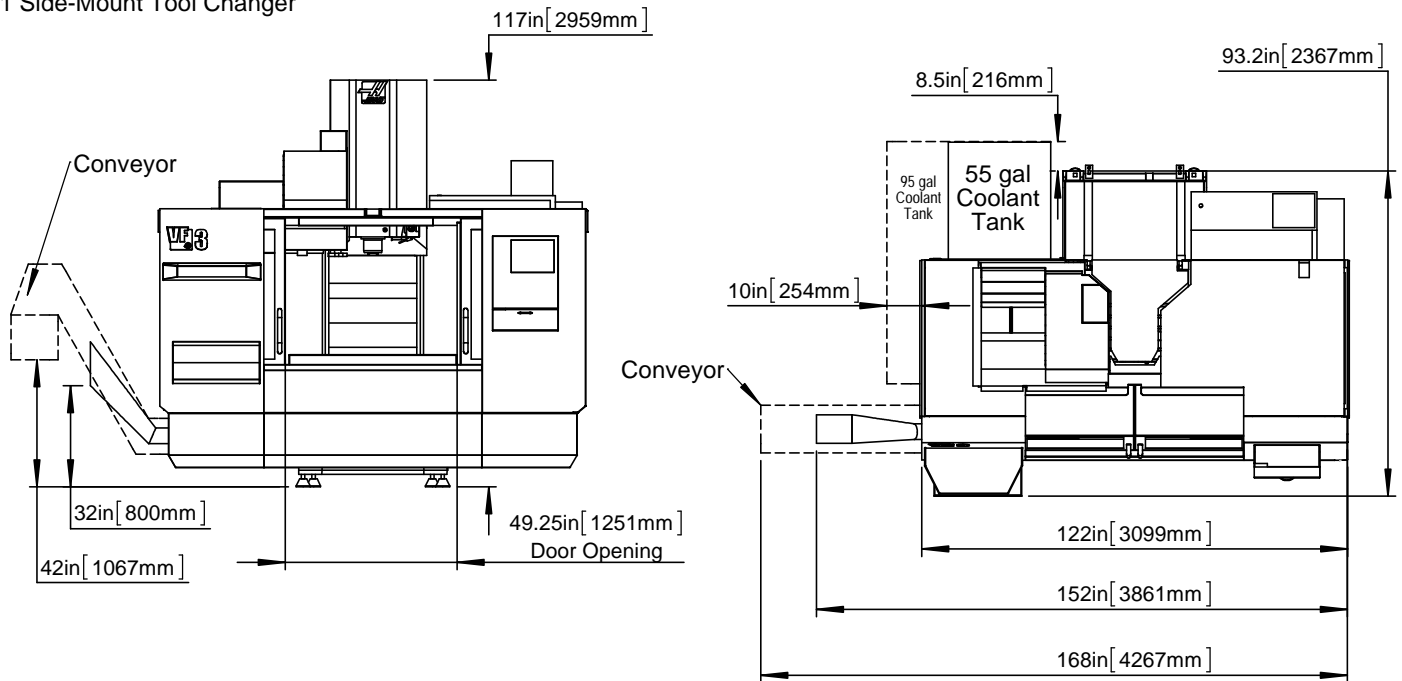

Standard Tool Changer:  
20 station Umbrella Tool Changer  
Optional Tool Changer(s):  
24+1 Side-Mount Tool Changer  
40+1 Side-Mount Tool Changer

### Operating Dimensions



Option: Multi-Auger Chip Conveyor

Minimum distance required to remove conveyor from mill is 85in [2159mm] without folding the conveyor

Minimum distance required to remove conveyor is 50in [1270mm] when the conveyor is folded at 90 degrees and folded down as it is removed

### Breakdown Height

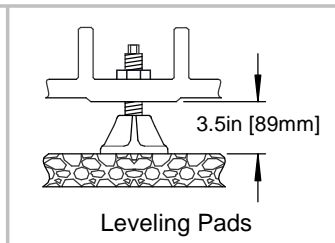

92.8in [2356mm] if the SMTC motor cover is removed and the motor is removed on non-SS machines.

94in [2388mm] if the Z-axis motor shroud is removed

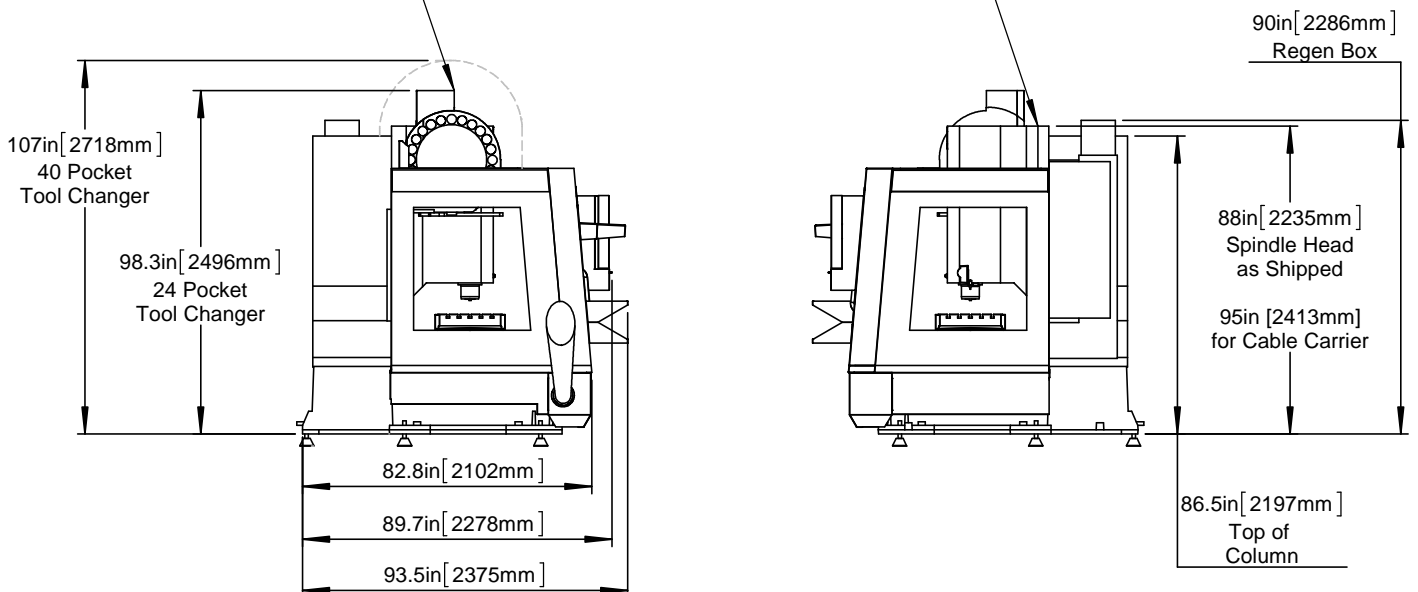



### Anchor Pattern

Note:  
Foundation must extend at least  
12in [305mm] from bored holes.

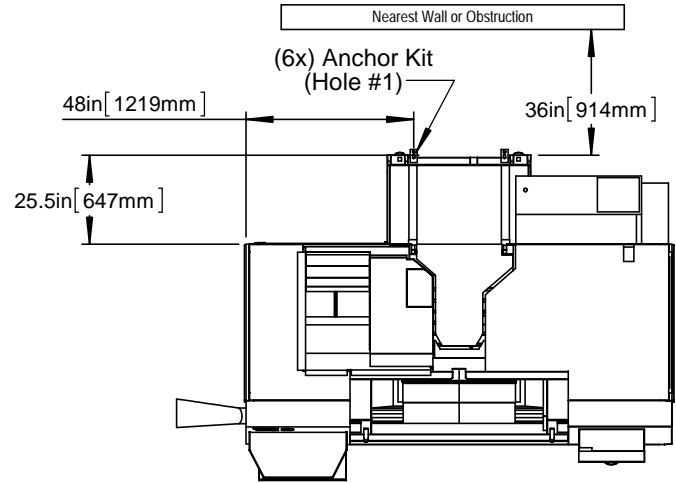
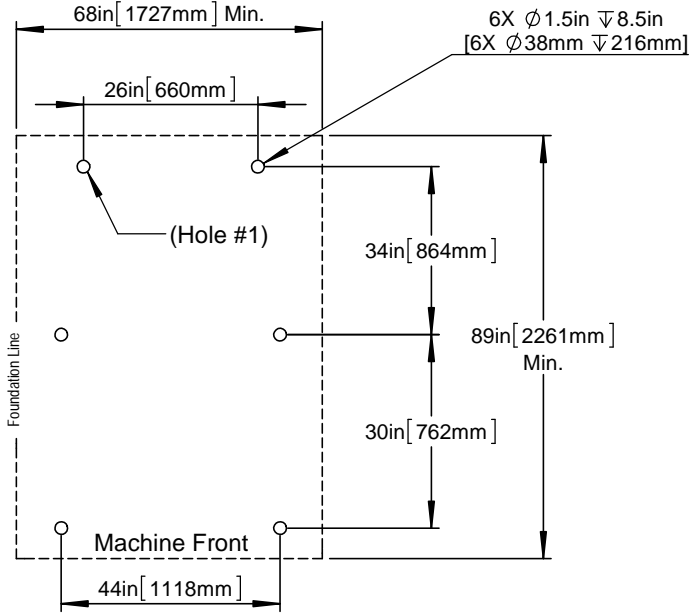

### Air and Power Inlets

- (E) Electrical Connection
- (A) Air Connection

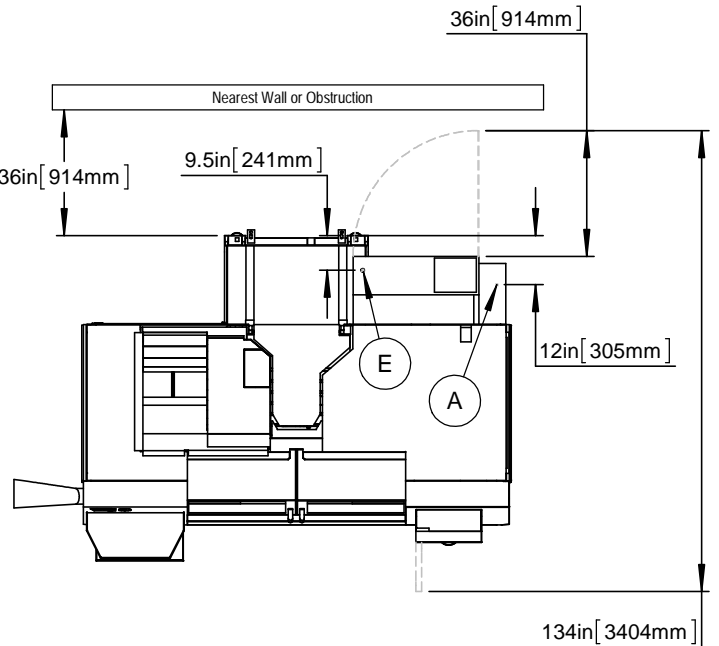
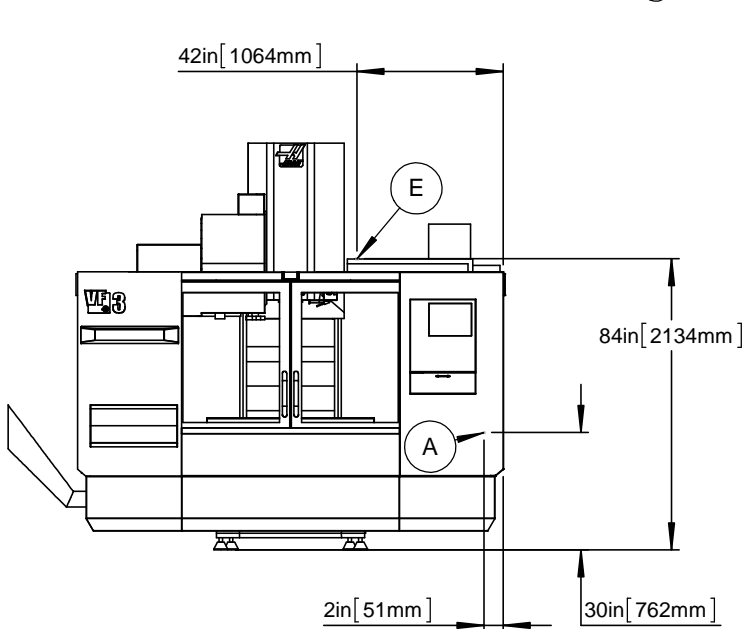



### X/Y Axis Clearances

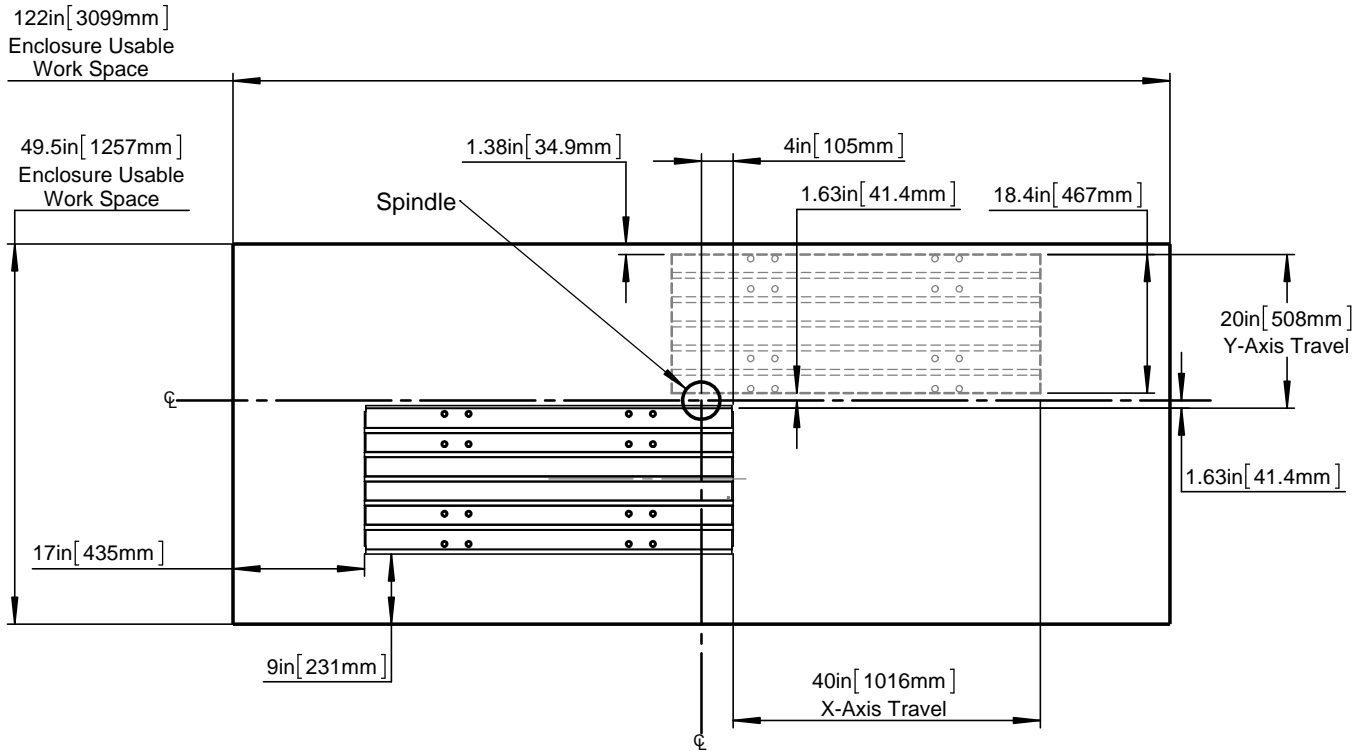

1. The table shown is at XY home, the dashed line is the table at max XY travels
2. Measurements are from the edge of the table to the nearest obstruction
3. Dimensions shown are at the top of the table, dimensions are reduced as the height increases (5 degree slope inside the sheet-metal)
4. Dimensions are symmetrical unless otherwise stated

### Z Axis Clearances

Notes:

1. The low-profile tables are 3in [76mm] lower than the standard table
2. P-Cool dimension varies based on P-Cool Position
3. Refer to the page on tool changer dimensions for tool changer heights

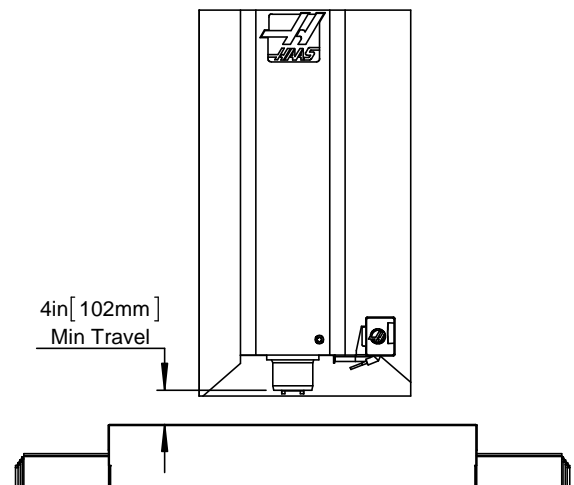
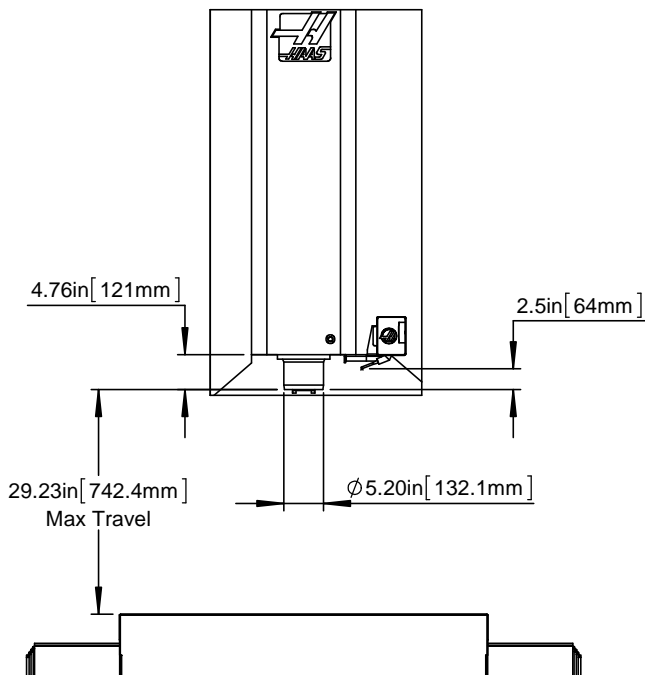
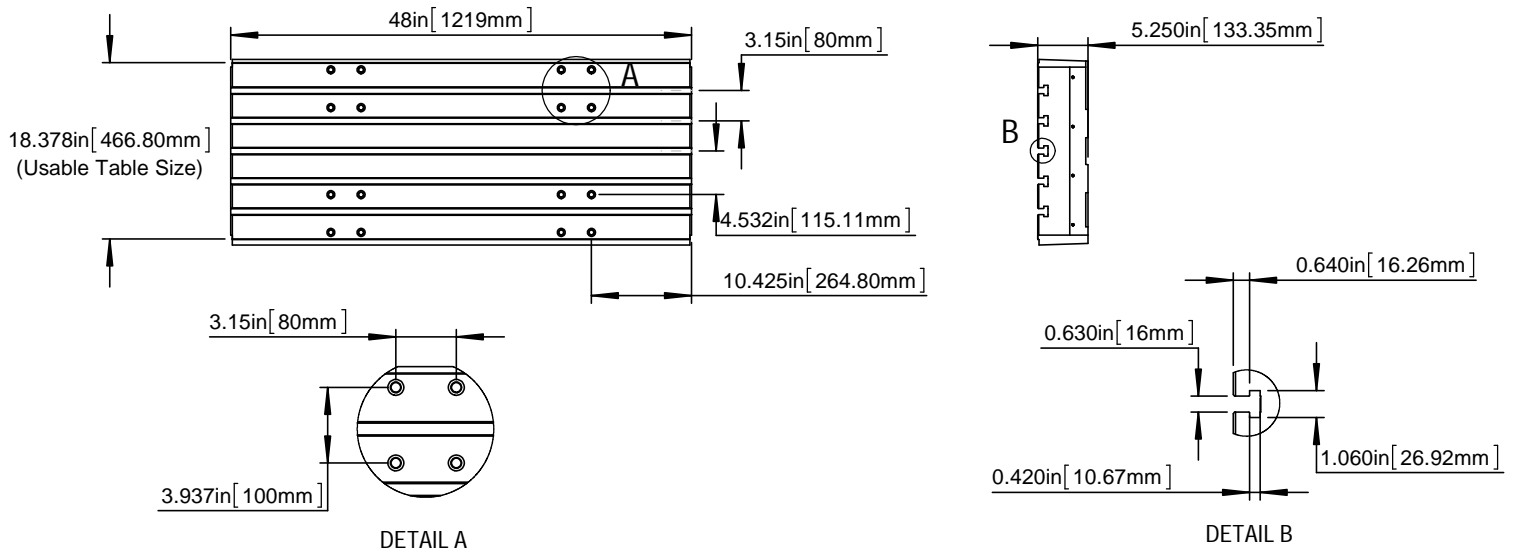
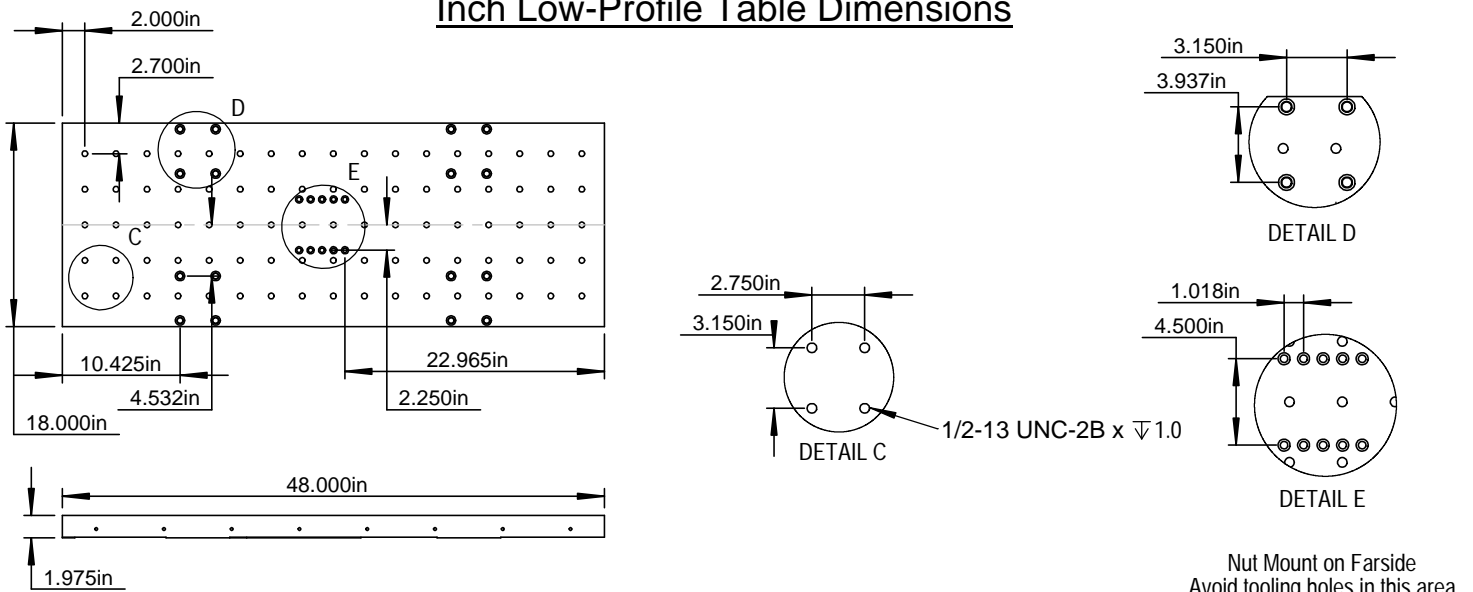

Table Dimensions



Inch Low-Profile Table Dimensions



Metric Low-Profile Table Dimensions

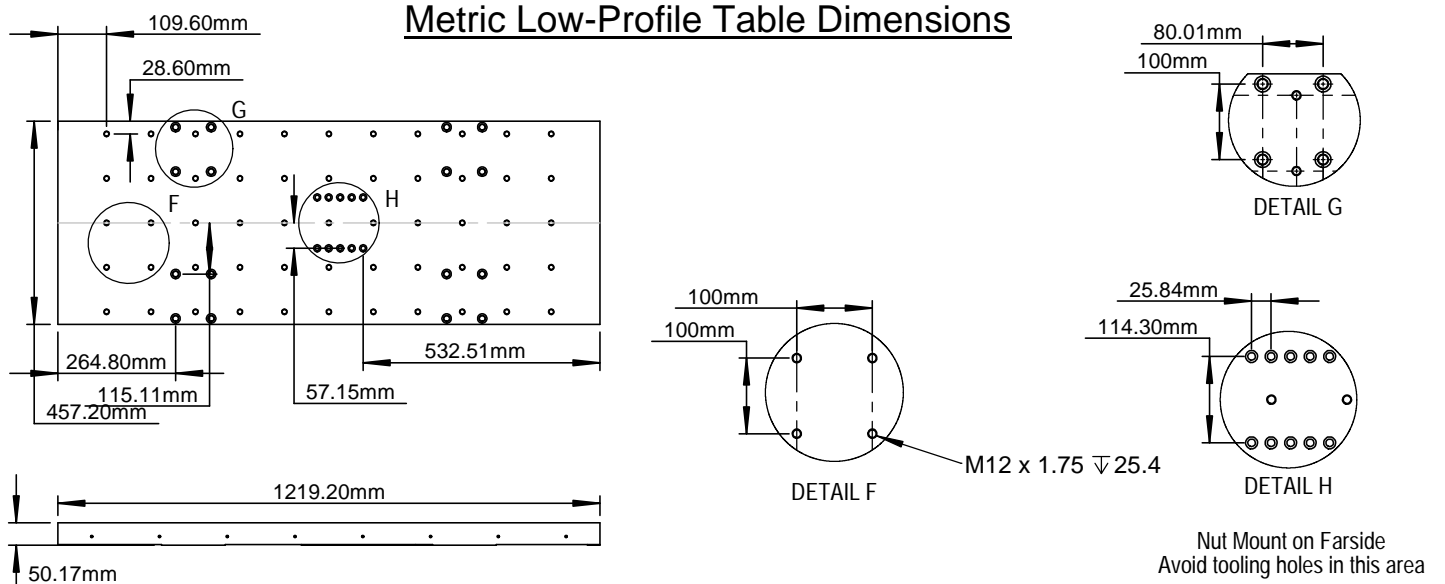



### Side-Mount Tool Changer Travels

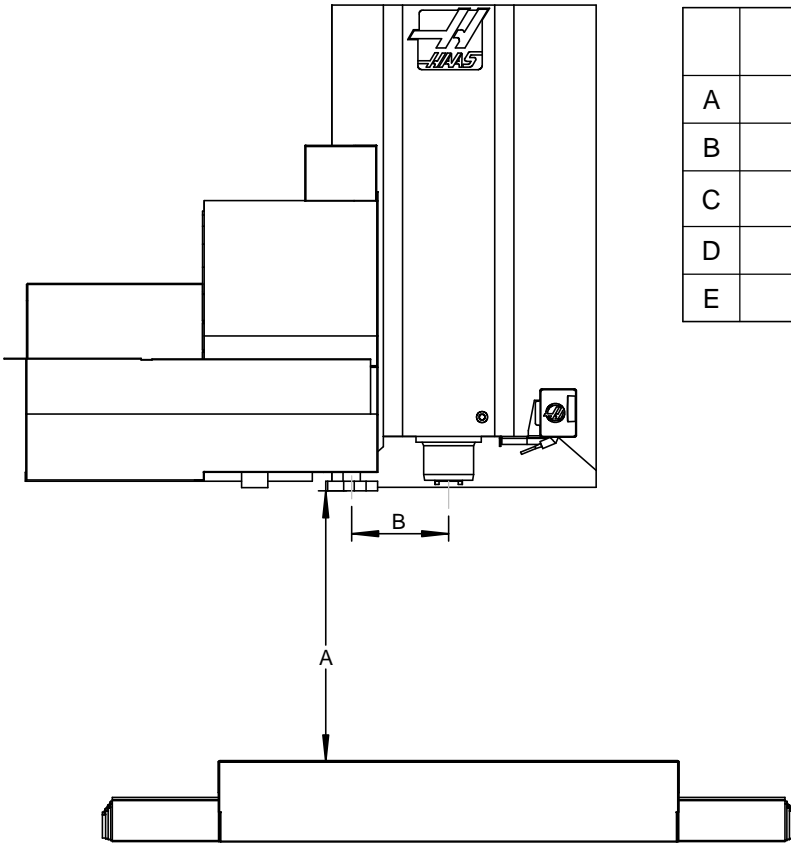

	24+1 Pocket		40+1 Pocket	
A	27.00in	685.8mm	26.75in	679.5mm
B	10.00in	254.0mm	12.00in	304.8mm
C	3.00in	76.2mm	4.00in	101.6mm
D	20.88in	530.3mm	25.88in	657.3mm
E	24.08in	611.7mm	29.07in	738.4mm

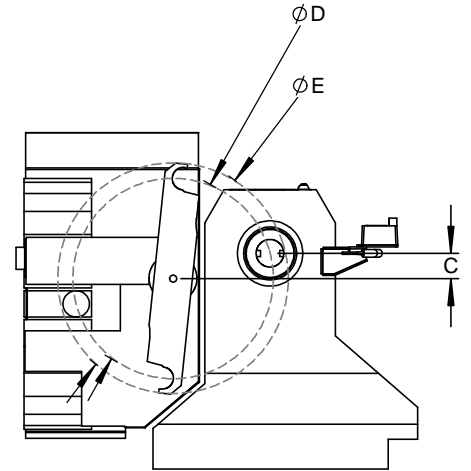

### Umbrella Tool Changer Travels

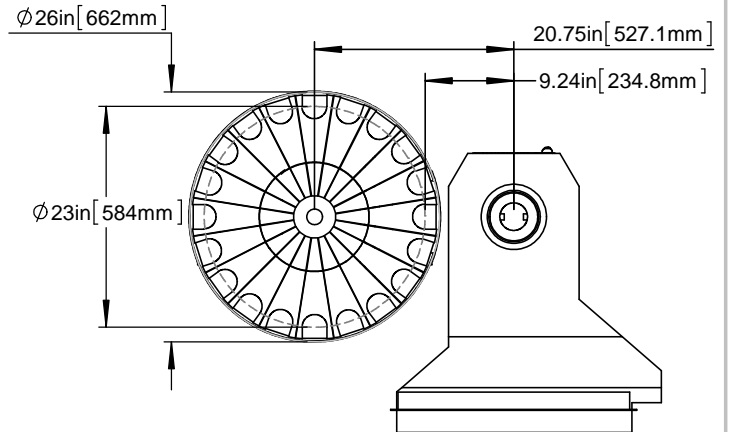
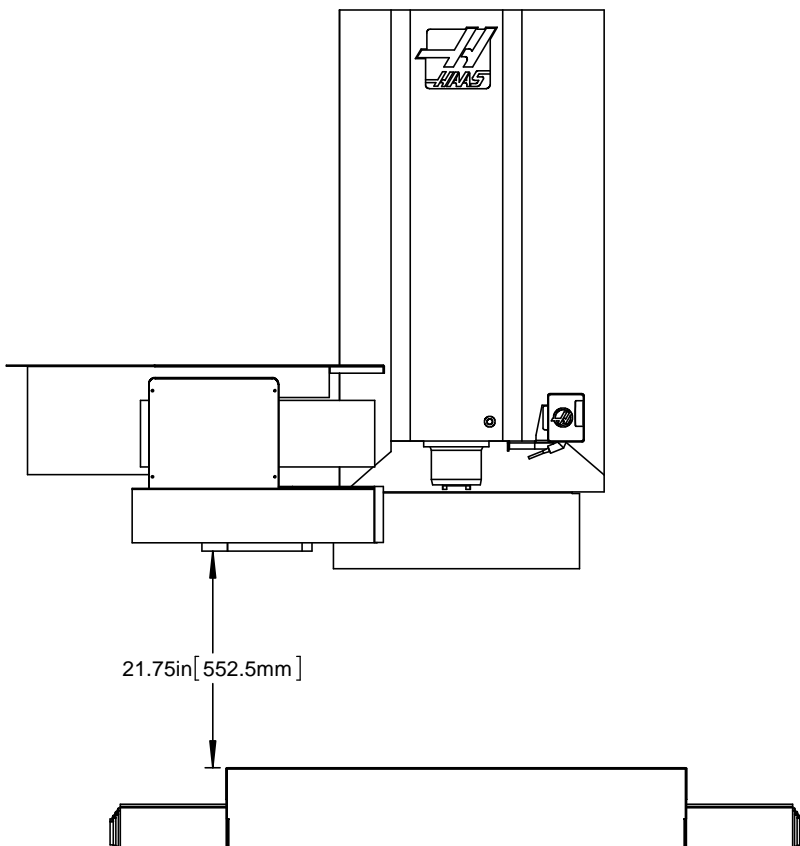

The Umbrella Tool Changer moves in towards the spindle to do a tool change.