

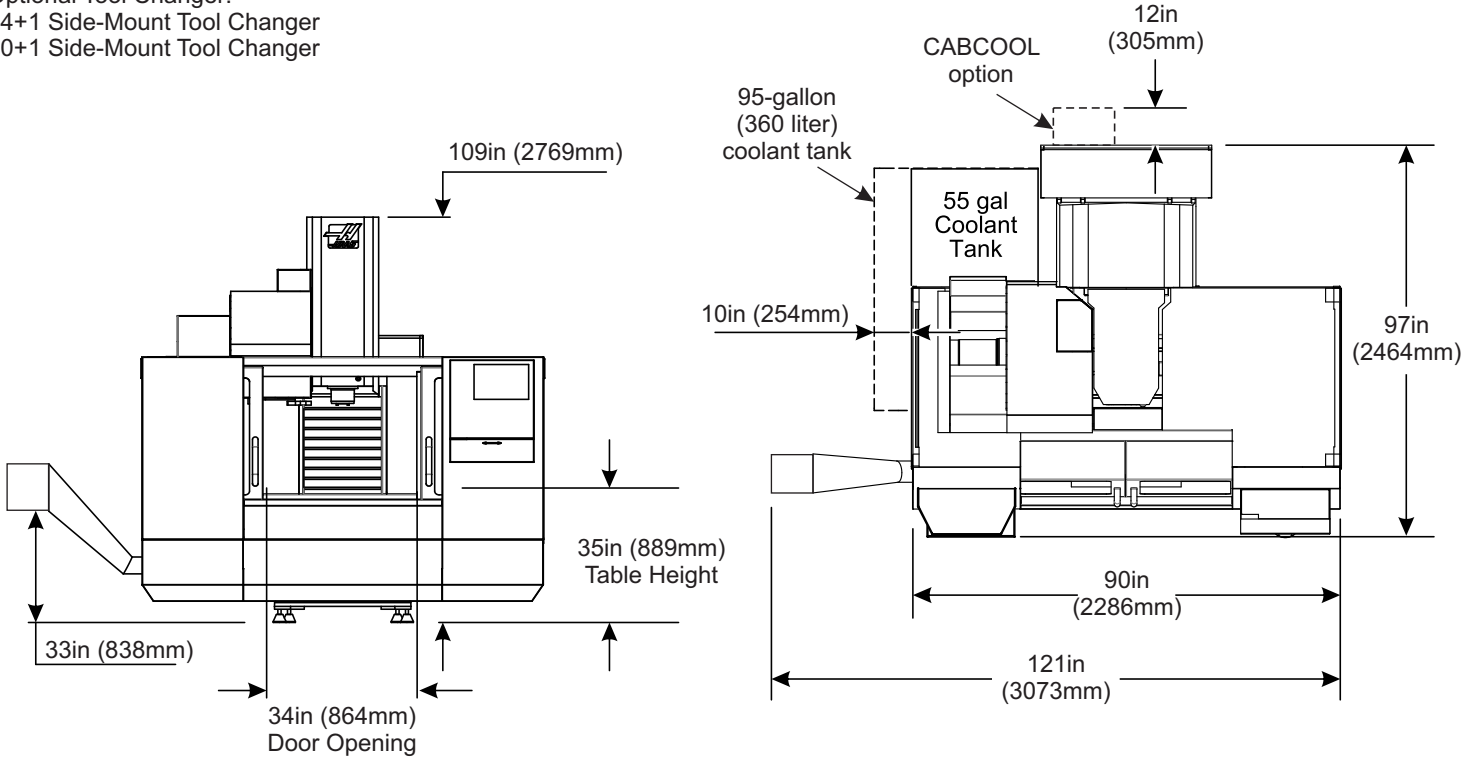

Standard Tool Changer:
20 Station Umbrella Tool Changer
Optional Tool Changer:
24+1 Side-Mount Tool Changer
40+1 Side-Mount Tool Changer

Operating Dimensions



Shipping Dimensions

Convenience package removed;
Control mounted on top
for shipping

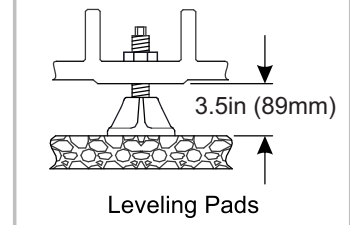
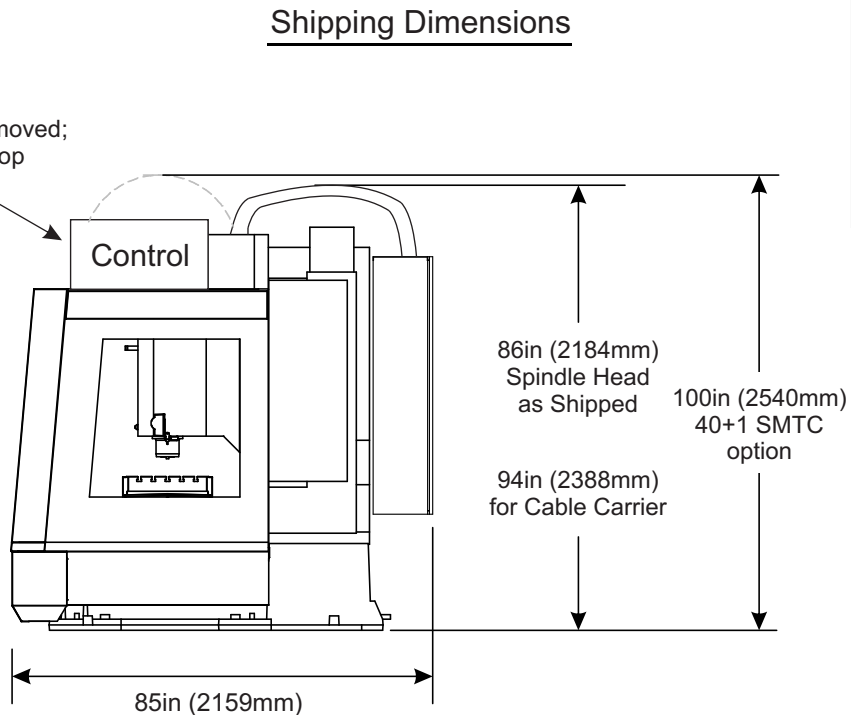

Shipping height (94"/2388mm or 100"/2540mm) and width (85"/2159mm) shown
Contact your local Haas Factory Outlet
for further breakdown information



Anchor Pattern

Note:
Foundation must extend at least
12in (305mm) from bored holes

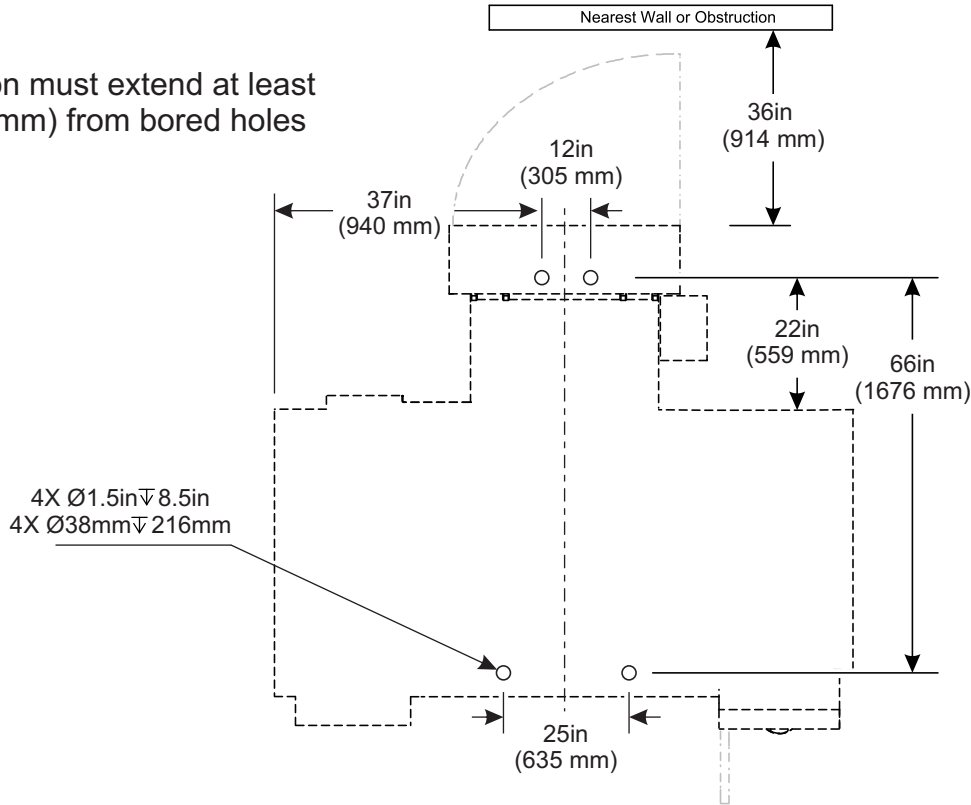

Air and Power Inlets

- (E) Electrical Connection
- (A) Air Connection

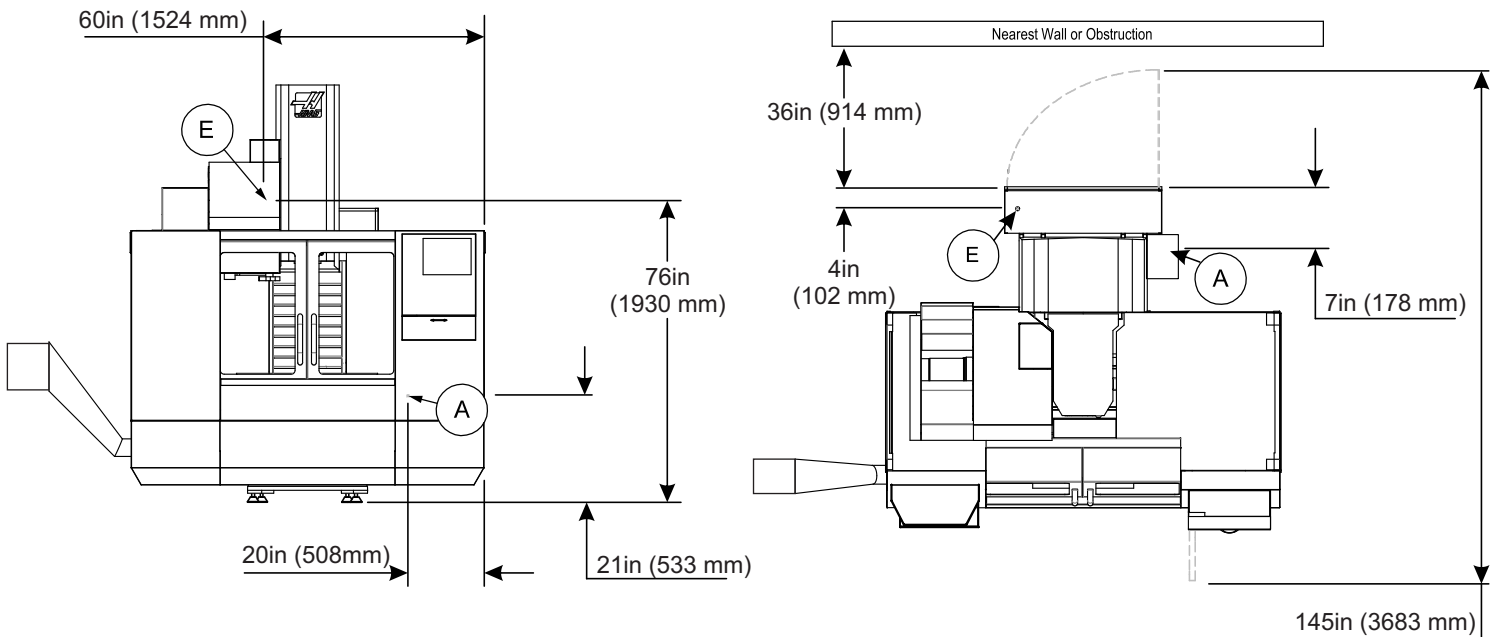



X/Y Axis Clearances

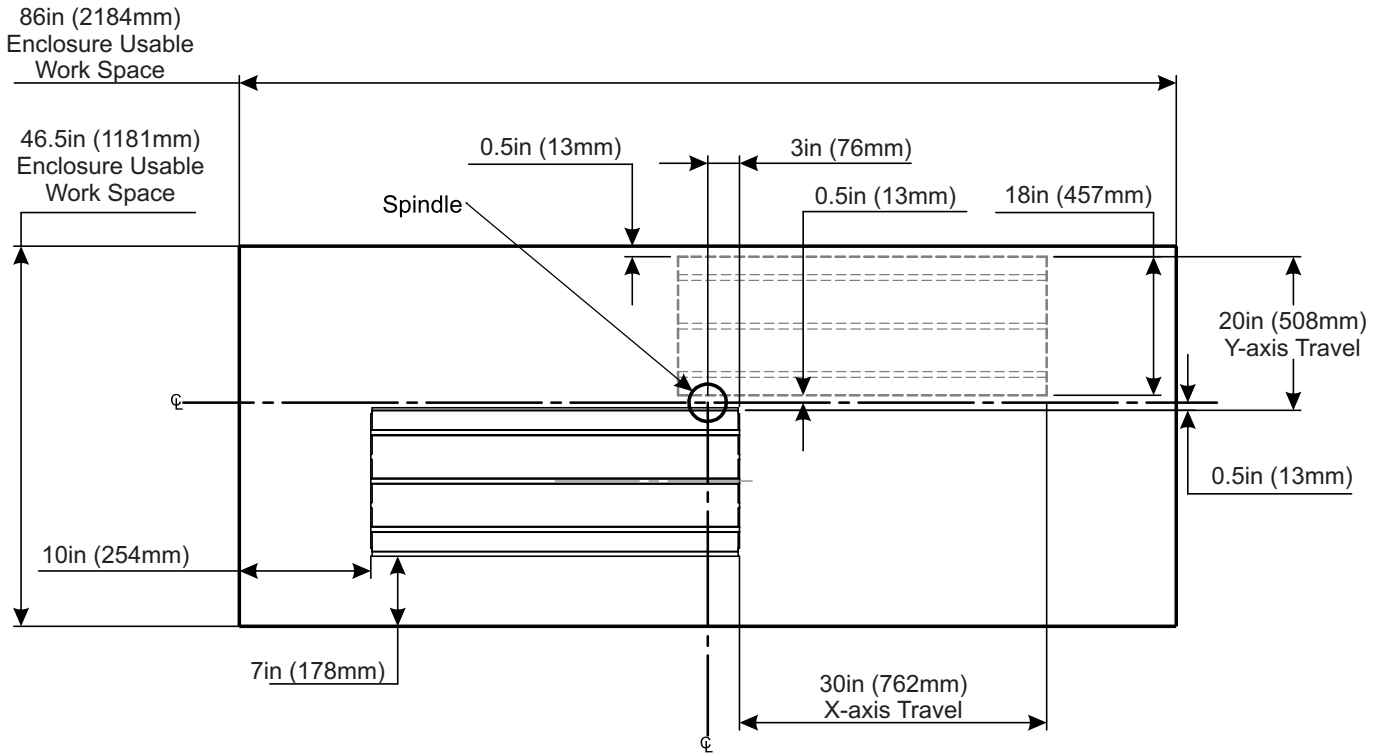

1. The table shown is at XY home, the dashed line is the table at max XY travels
2. Measurements are from the edge of the table to the nearest obstruction
3. Dimensions shown are at the top of the table, dimensions are reduced as the height increases (5 degree slope inside the sheet-metal)
4. Dimensions are symmetrical unless otherwise stated

Z Axis Clearances

Notes:

1. P-Cool dimension varies based on P-Cool position
2. Refer to the page on tool changer dimensions for tool changer heights

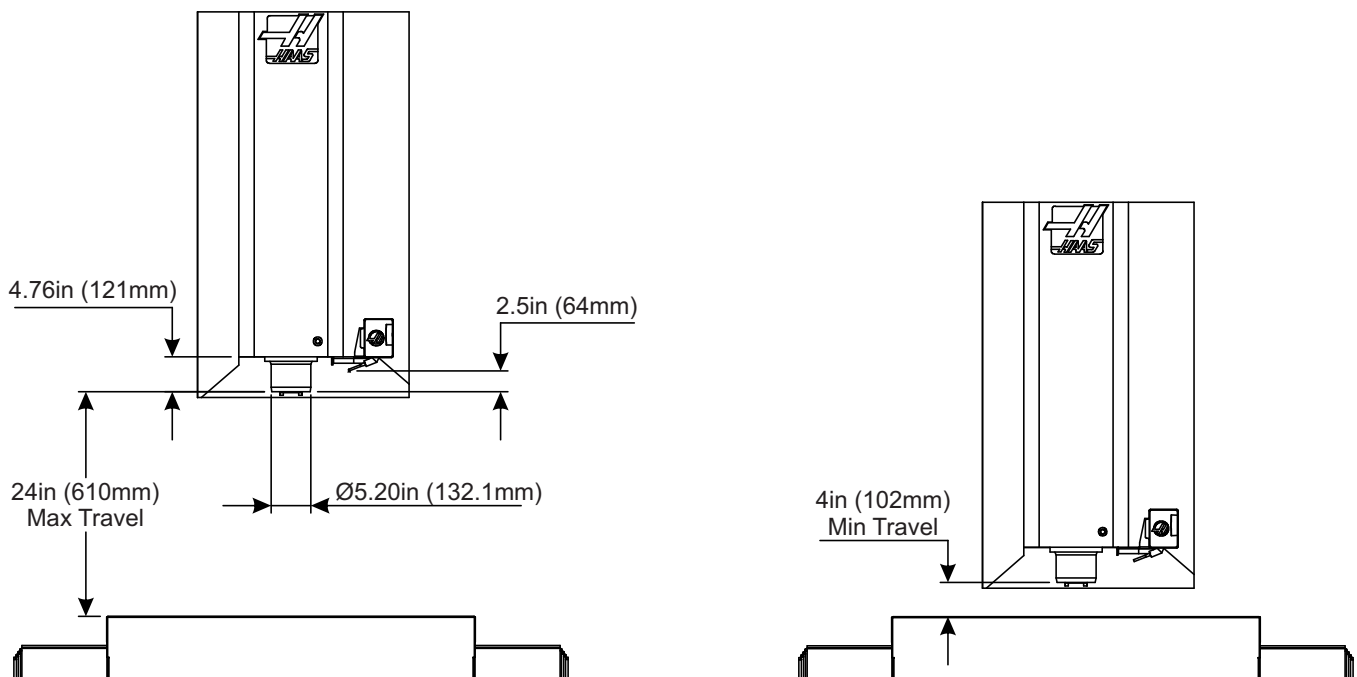
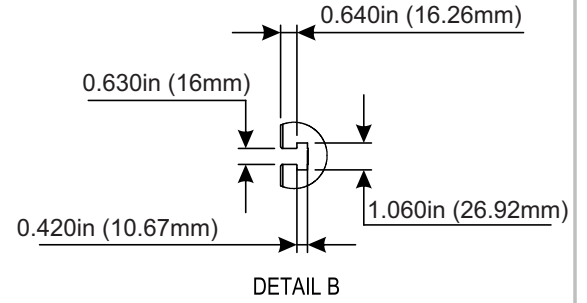
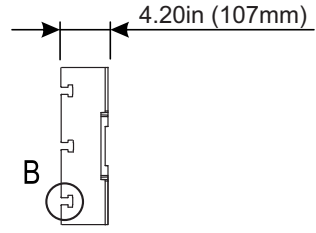
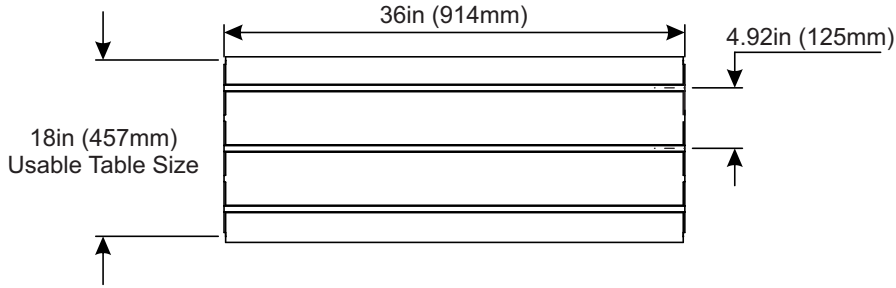
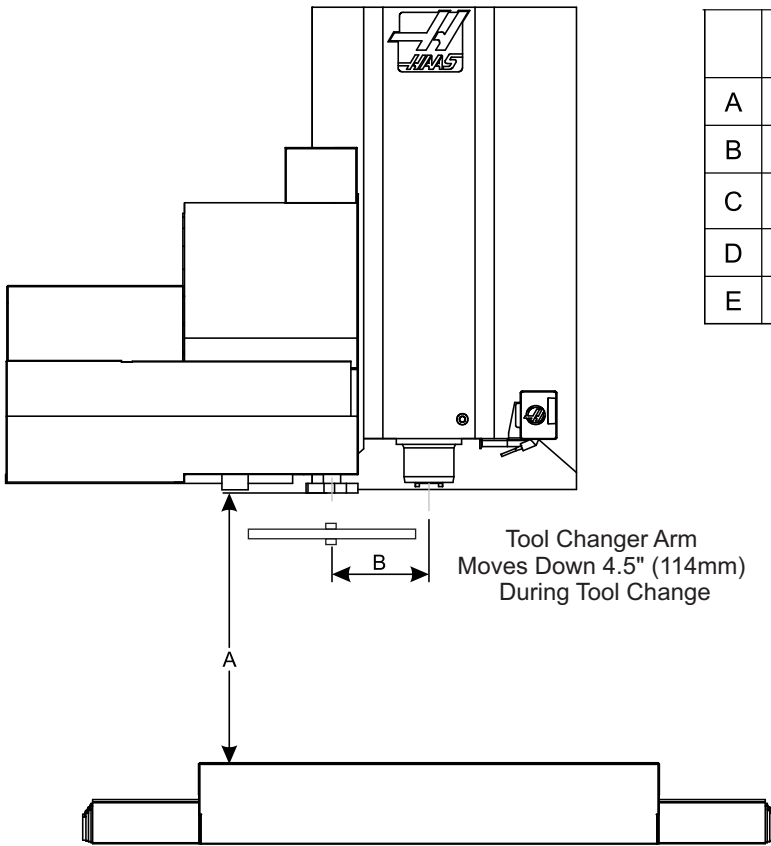



Table Dimensions



Side-Mount Tool Changer Travels



	24+1 SMTC		40+1 SMTC	
A	22.5in	572mm	21in	533mm
B	10in	254mm	13in	330mm
C	3in	76mm	5in	127mm
D	21in	533mm	27in	686mm
E	24in	610mm	30in	762mm

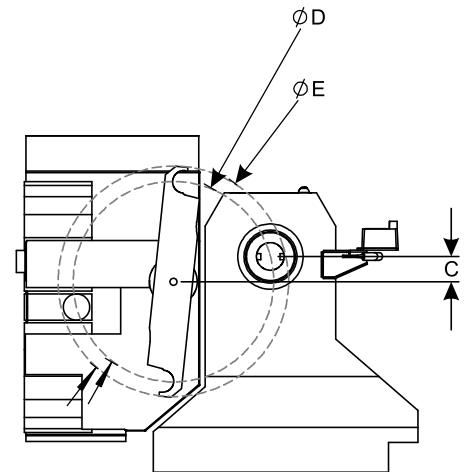

Umbrella Tool Changer Travels

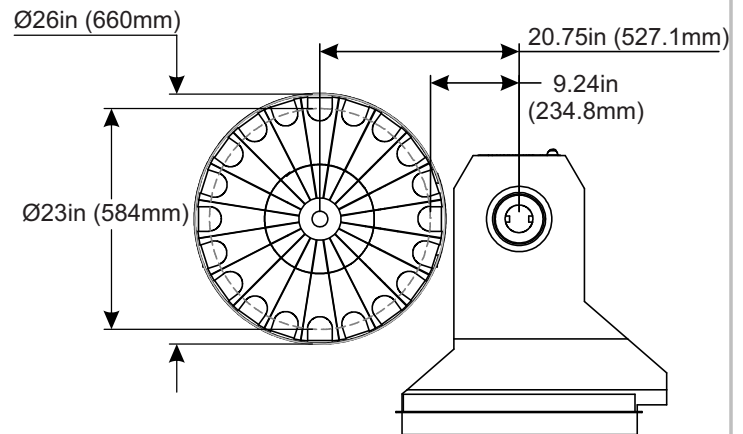
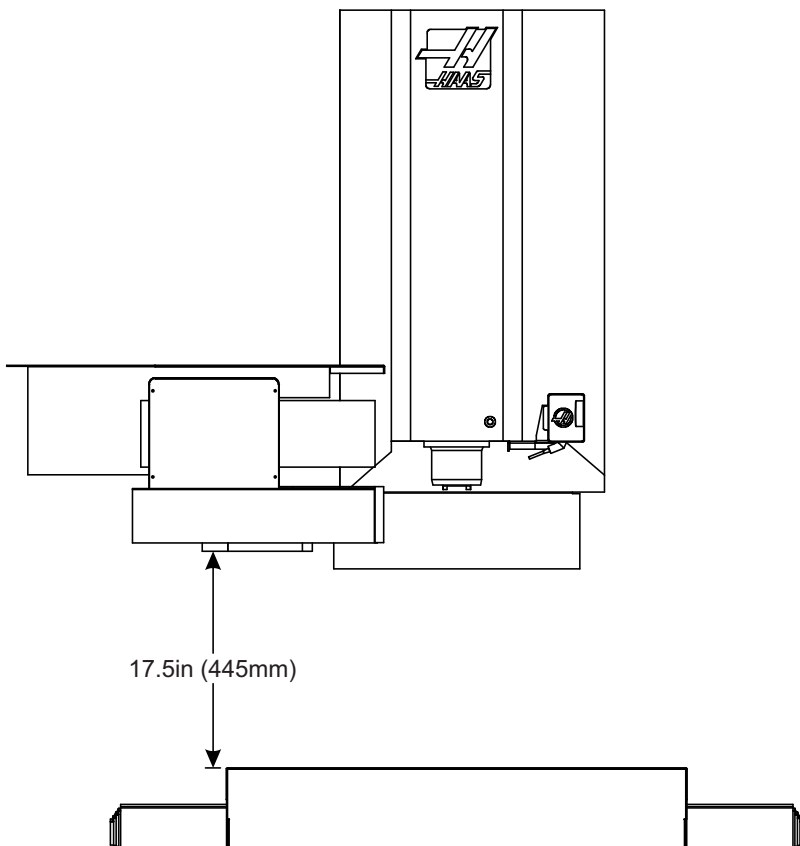

The Umbrella Tool Changer moves in towards the spindle to do a tool change.