

*Coolant Tank Dimensions
55 Gallon (208.2L): 84.4" (2143 mm) X 27.5" (699 mm)

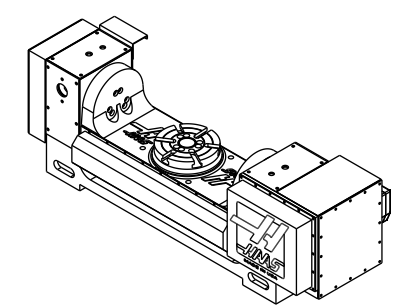

TR160

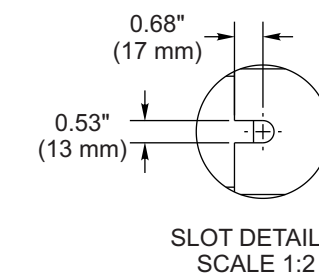
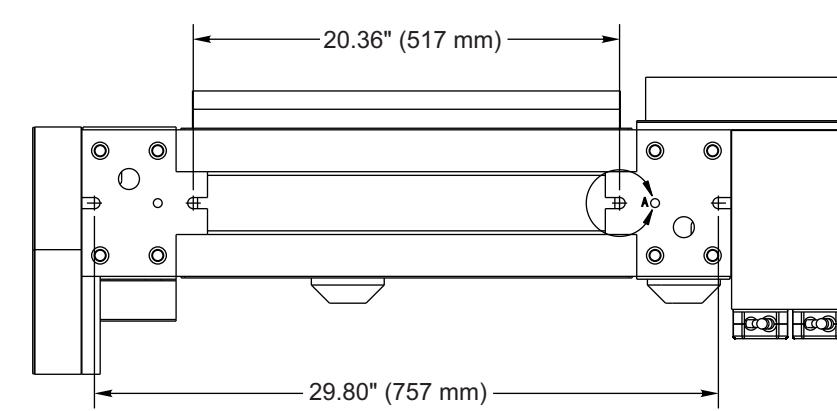
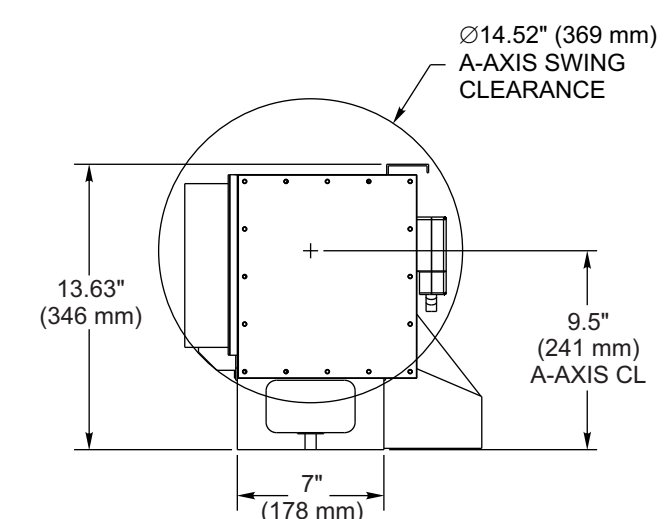
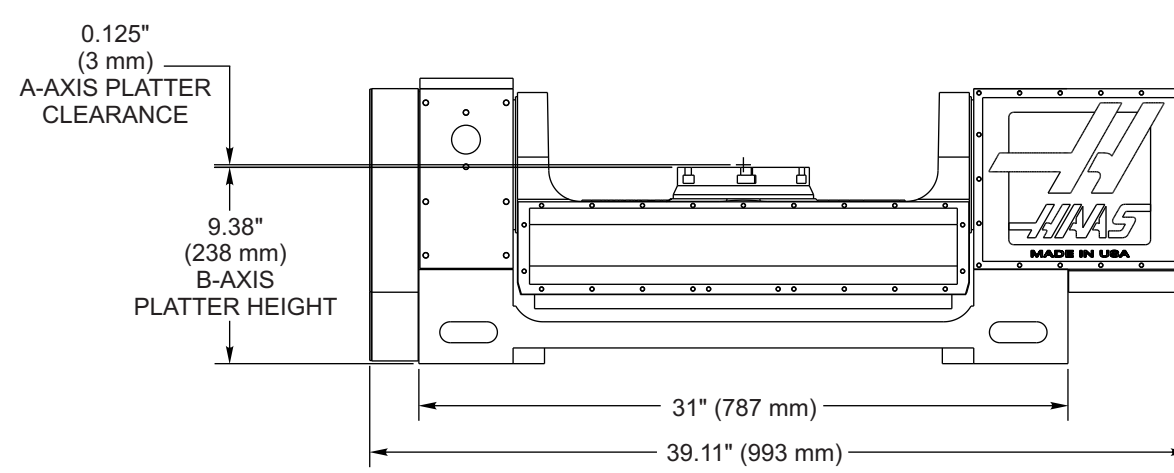
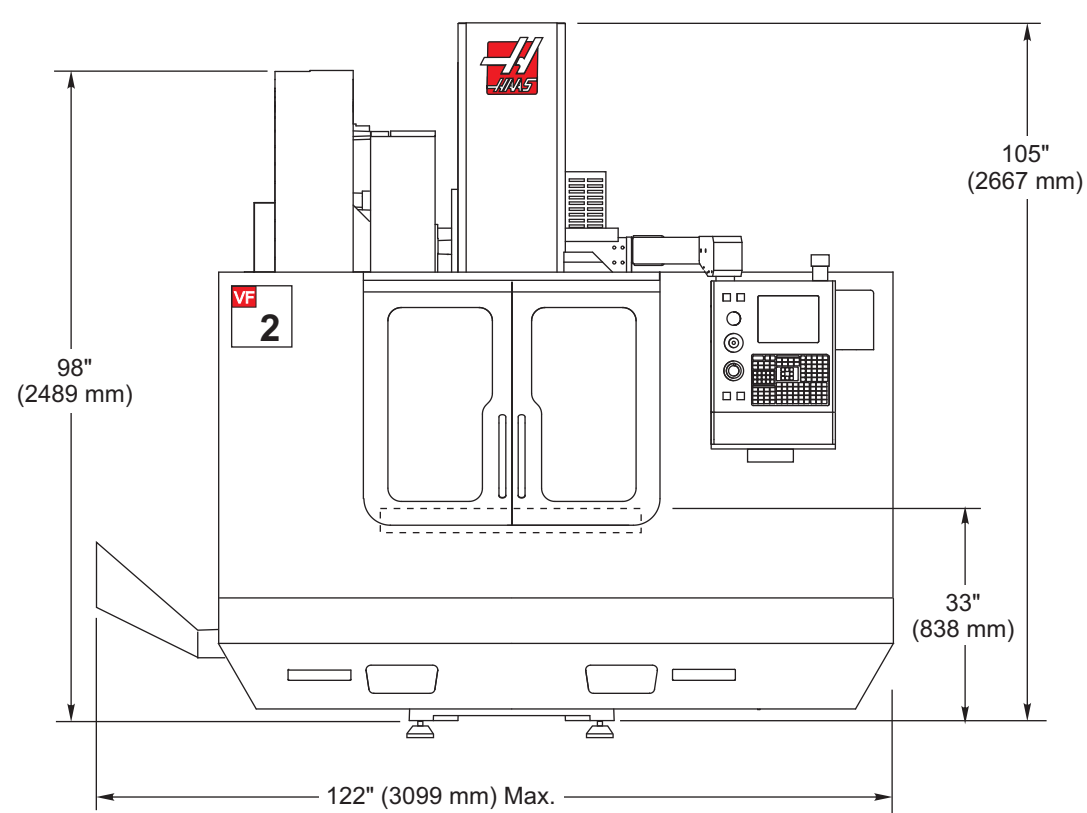
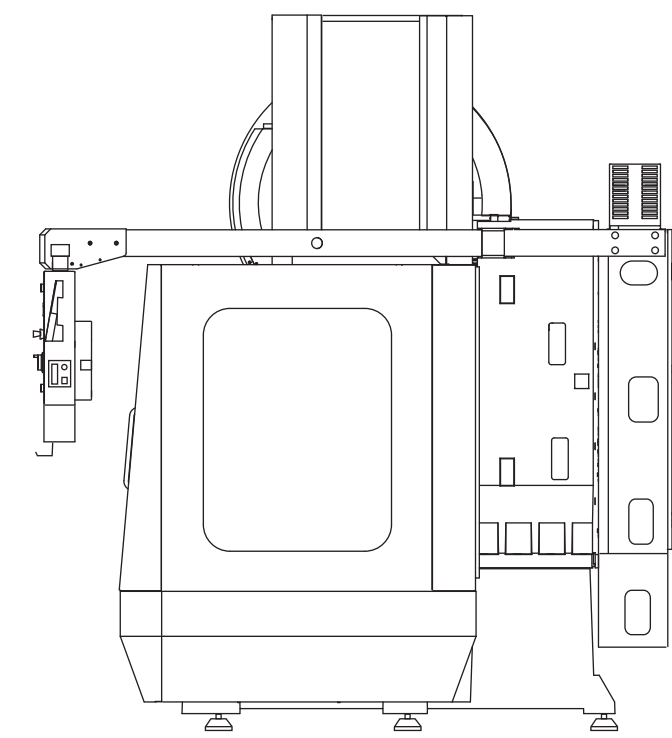
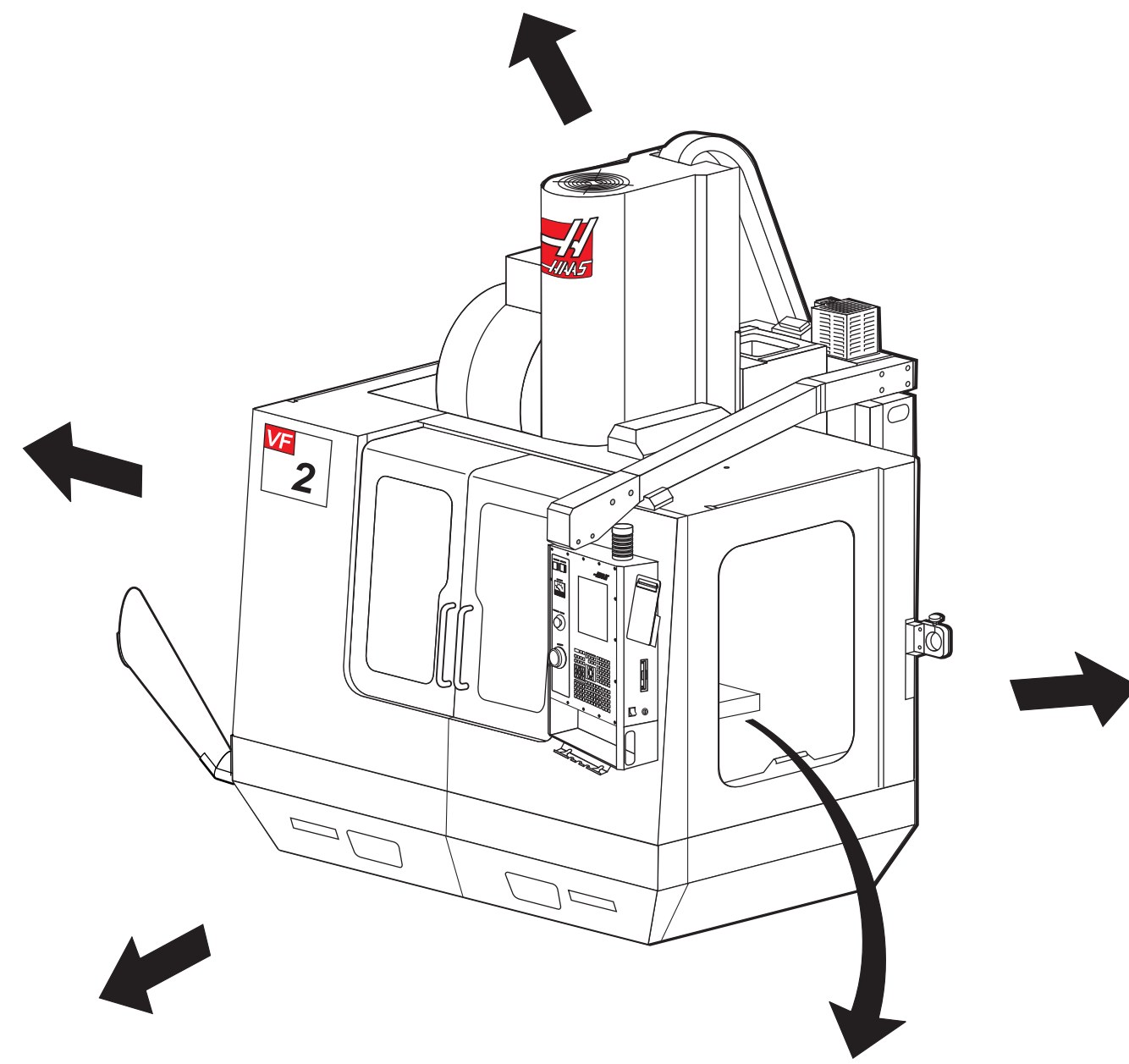
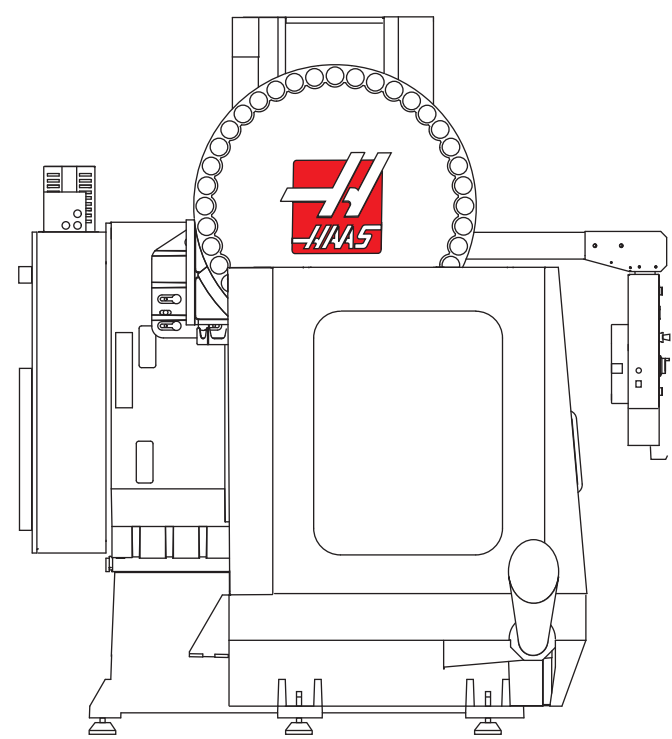
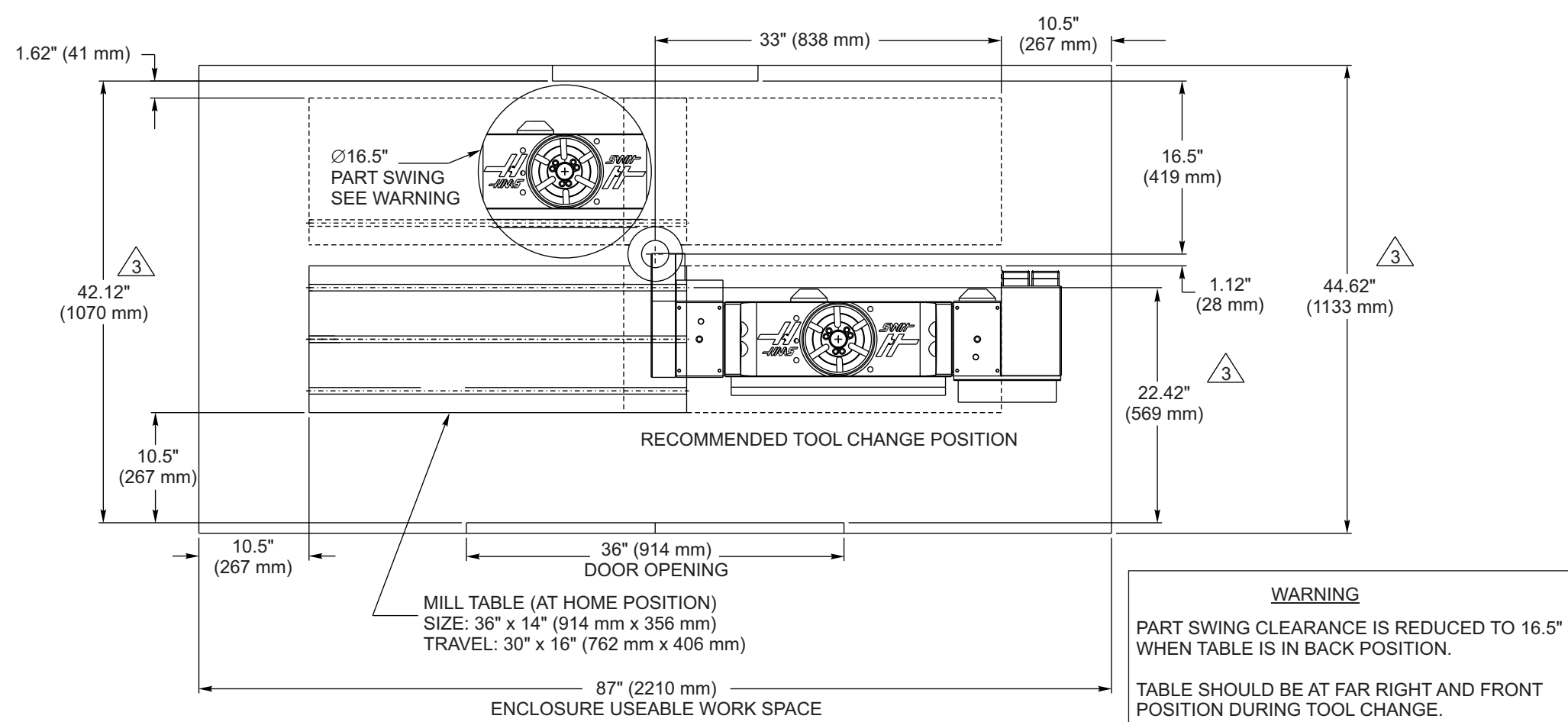

WARNING
PART SWING CLEARANCE IS REDUCED TO 16.5" WHEN TABLE IS IN BACK POSITION.
TABLE SHOULD BE AT FAR RIGHT AND FRONT POSITION DURING TOOL CHANGE.

NOTES:
1. TABLE POSITION(S) AT MAX X & Y TRAVELS.
2. MEASUREMENTS ARE FROM THE EDGE OF MILL TABLE TO NEAREST OBSTRUCTION (i.e. ENCLOSURE, WAY COVER, DOORS, ETC.).
3. DIMENSIONS ARE REDUCED AS HEIGHT ABOVE TABLE INCREASES; i.e. FRONT OF ENCLOSURE IS SLOPED 5 INWARD FROM BOTTOM TO TOP. DIMENSIONS SHOWN ARE AT TABLE TOP HEIGHT.

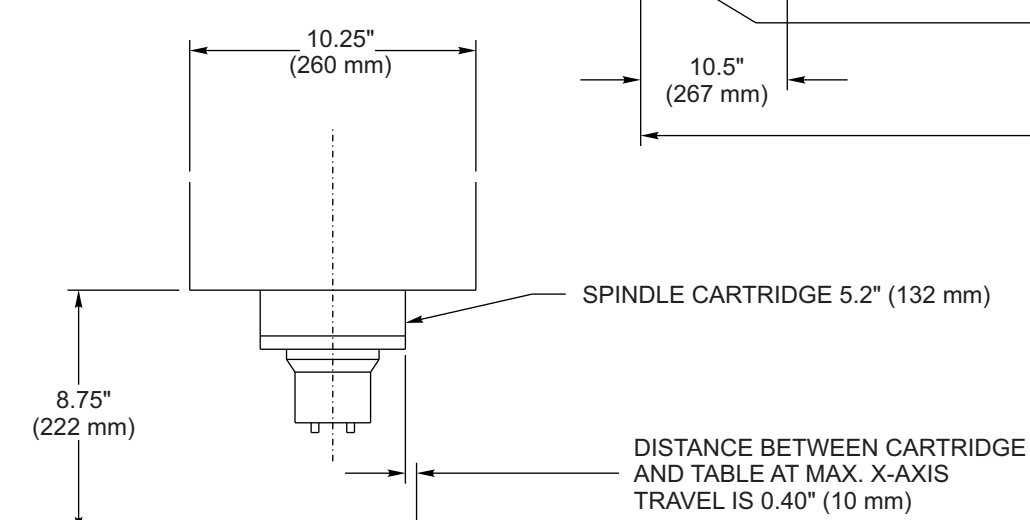
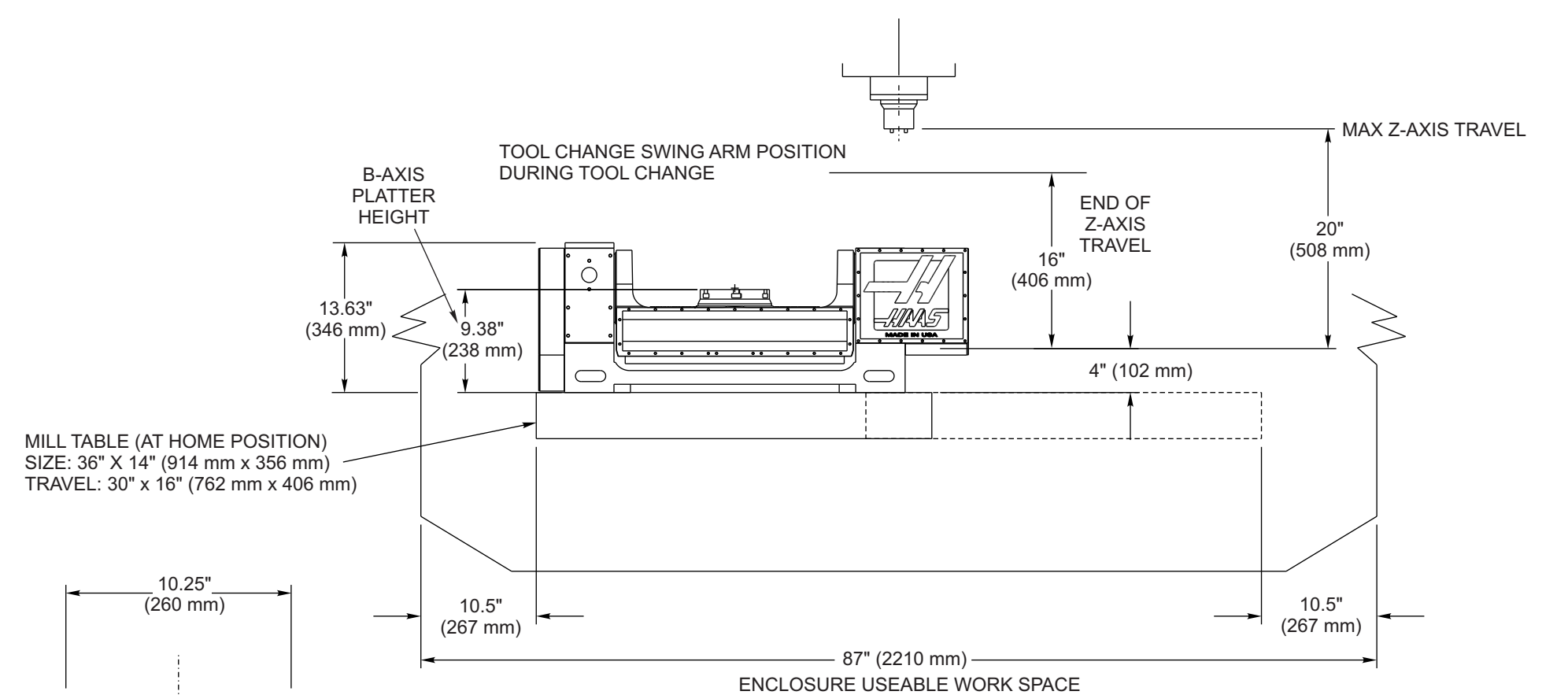
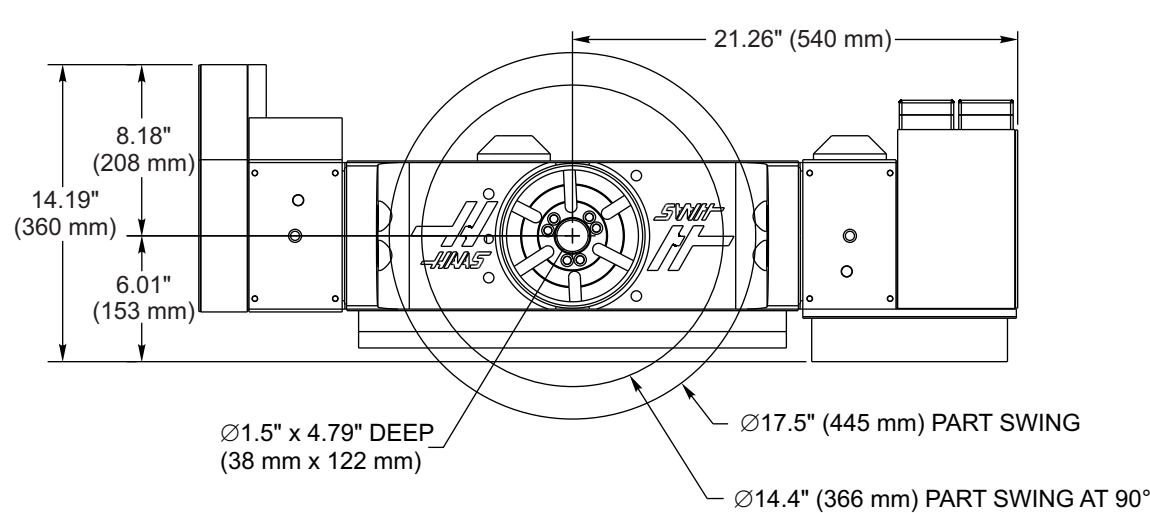

DETAIL A
SCALE 1:10