

Note:
Foundation must extend at least 1 Ft. (305 mm) from bored holes.
Machines with outriggers (VF-10,12) must have the foundation extend at least 1 ft. (305 mm) from the outrigger leveling pads.

VF-12 Anchor Pattern

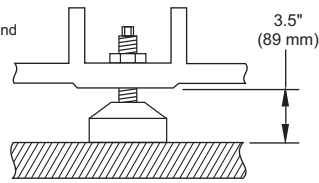

Leveling Pad Pin Dimension

Reference ES0039
Machine Clearance Heights

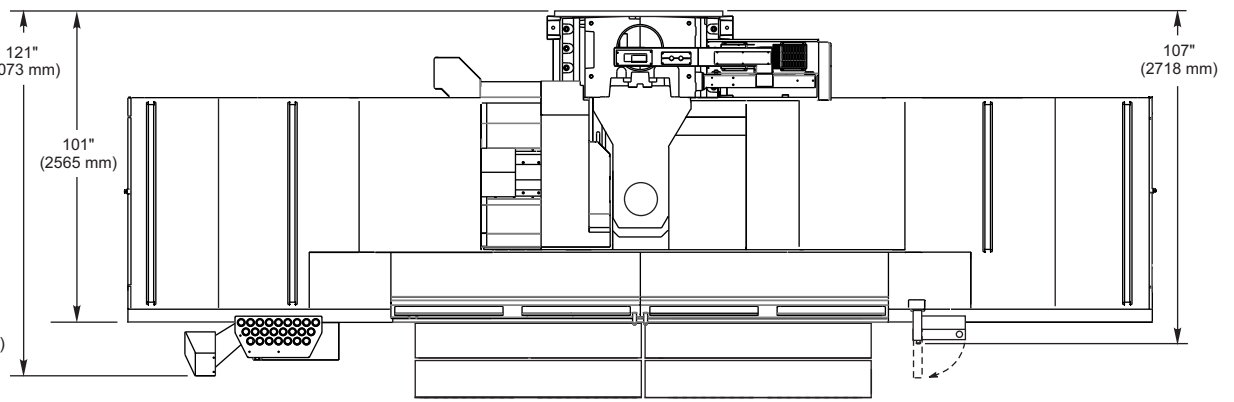

2x Two-Step Operator Platform included
Dimensions of each platform:
Length: 72.5" (1842 mm)
Width: 23.5" (570 mm)
Height: 12.5" (318 mm)

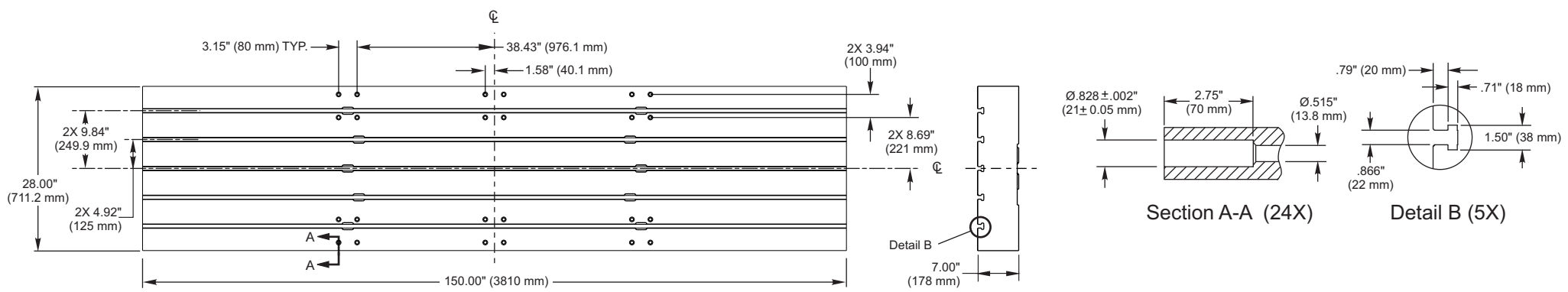
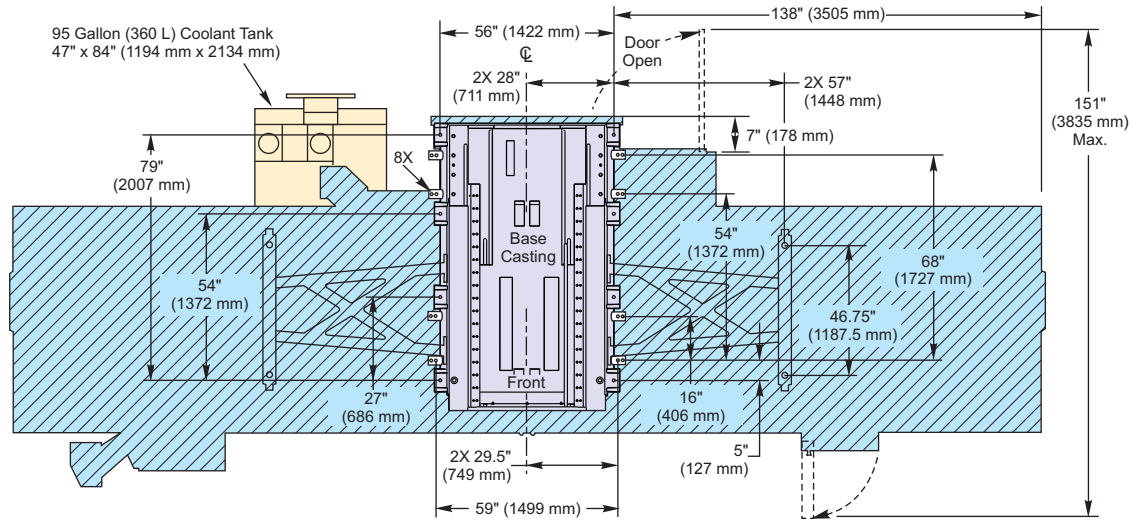
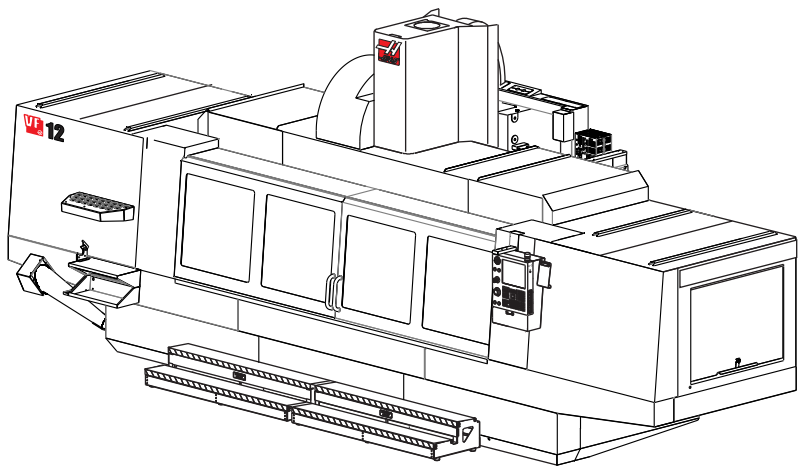
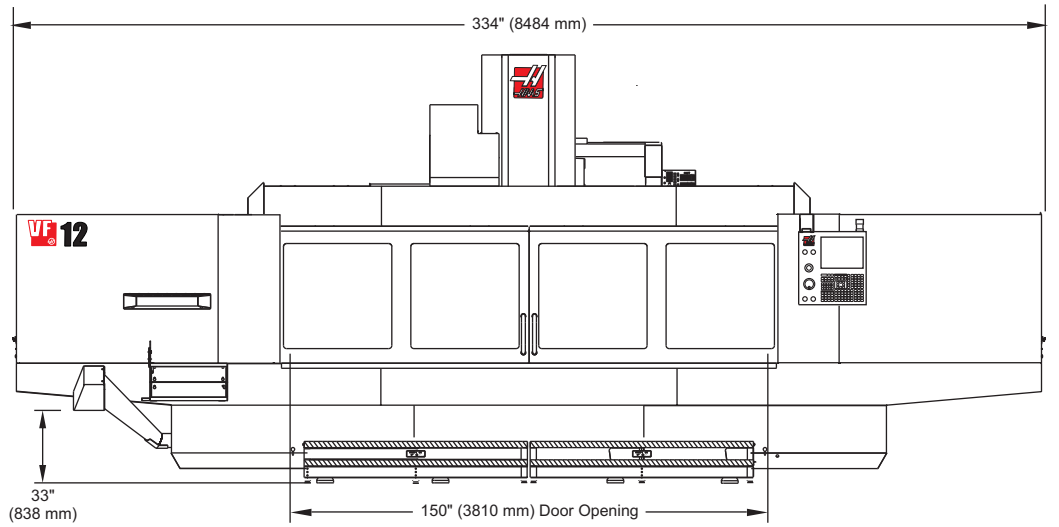
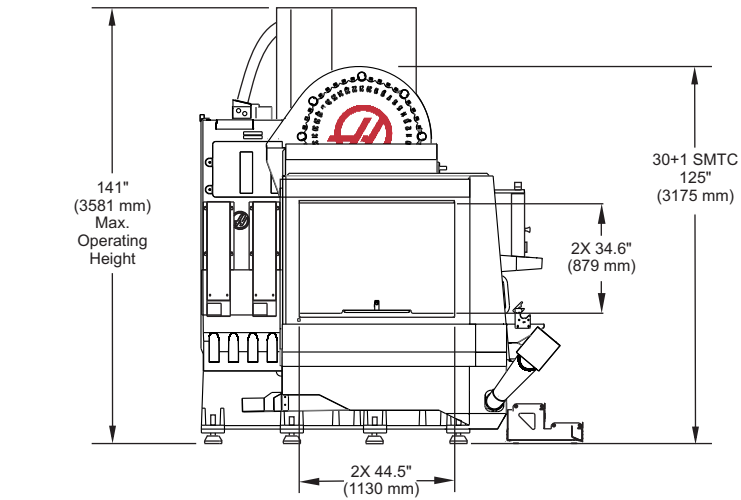

VF-12 Table Dimensions

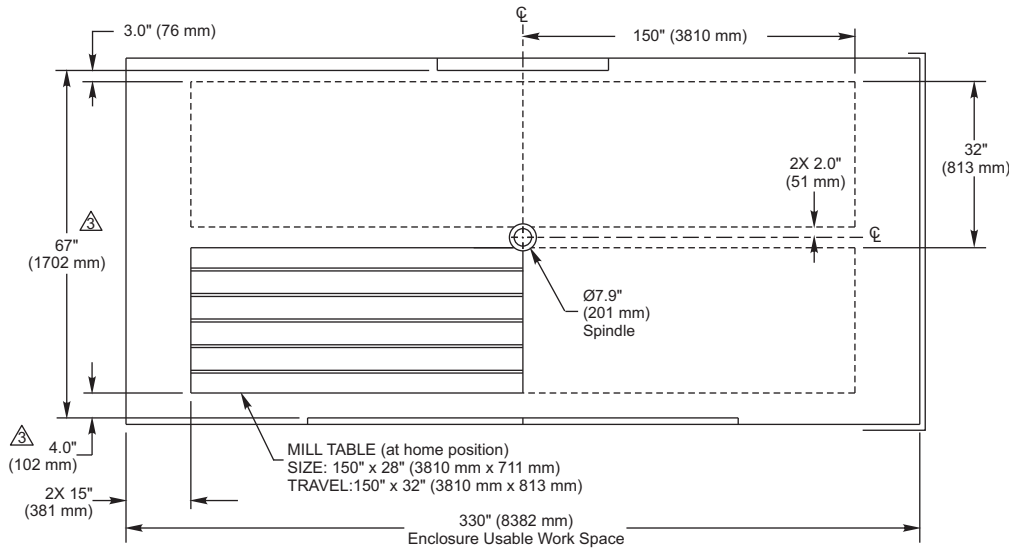

Top View

VF-12/50 Enclosure Usable Work Space

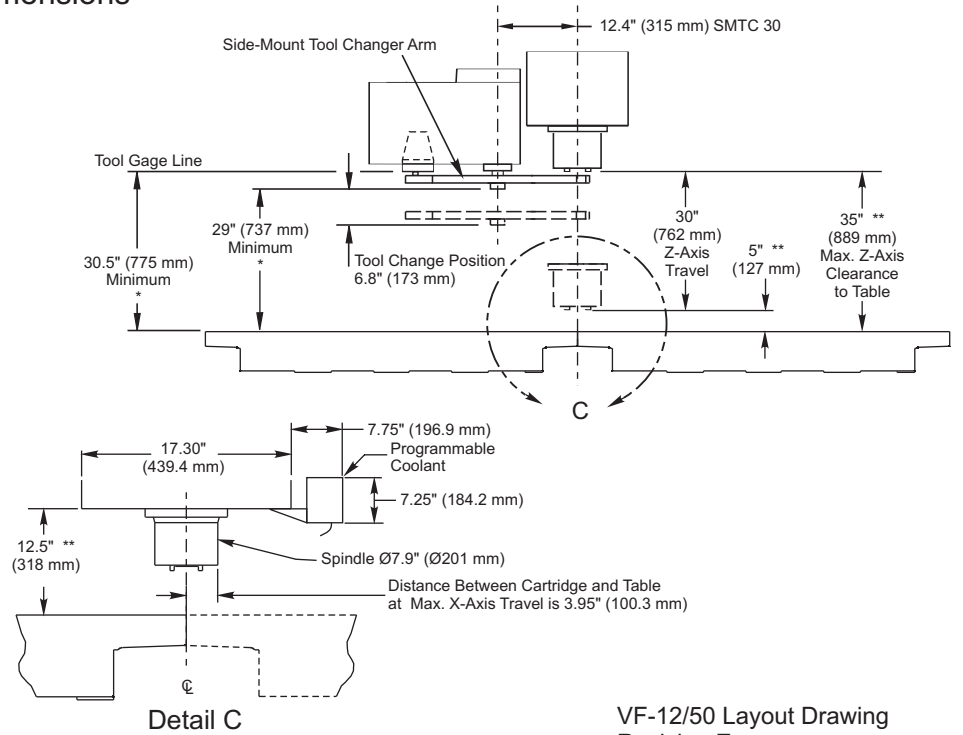

Detail C
Front View