

Leveling Pad Pin Dimension

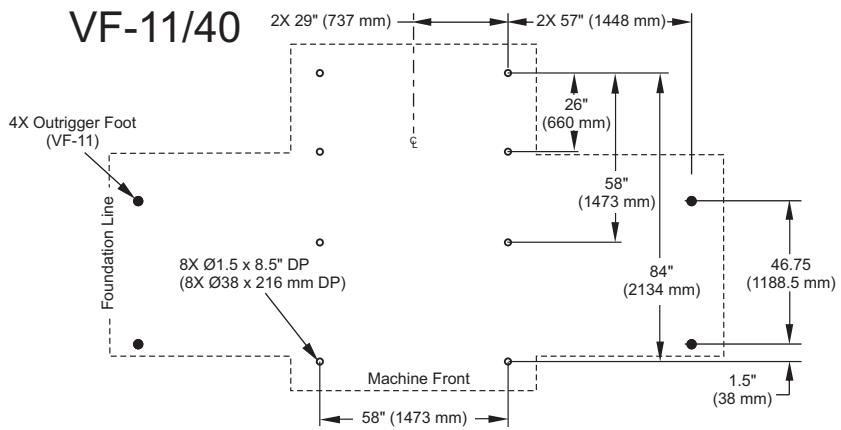

Note:
Foundation must extend at least 1 Ft. (305 mm) from bored holes.
Machines with outriggers (VF-11) must have the foundation extend at least 1 ft. (305 mm) from the outrigger leveling pads.

VF-11 Anchor Pattern
This anchor pattern applies for machines built after January 2013.

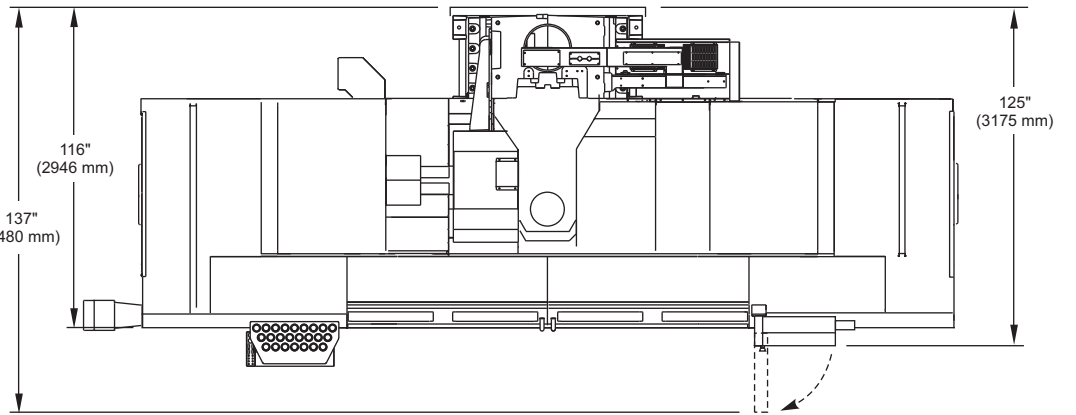

2x Two-Step Operator Platform included (not shown)
Dimensions of each platform:
Length: 72.5" (1842 mm)
Width: 23.5" (570 mm)
Height: 12.5" (318 mm)

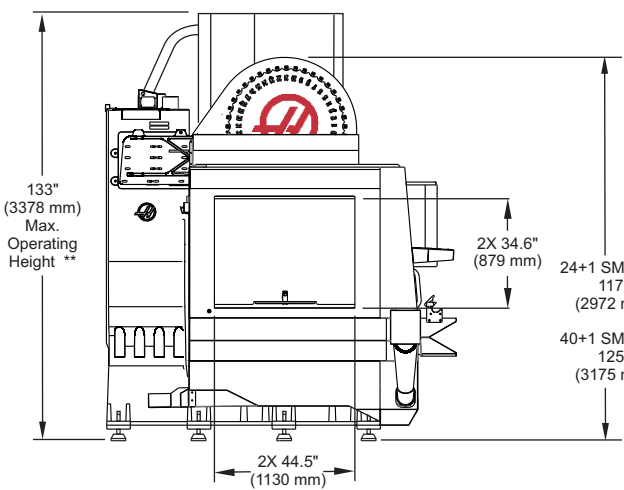

** Extended Z-Axis Clearance Option add 8" (203 mm)

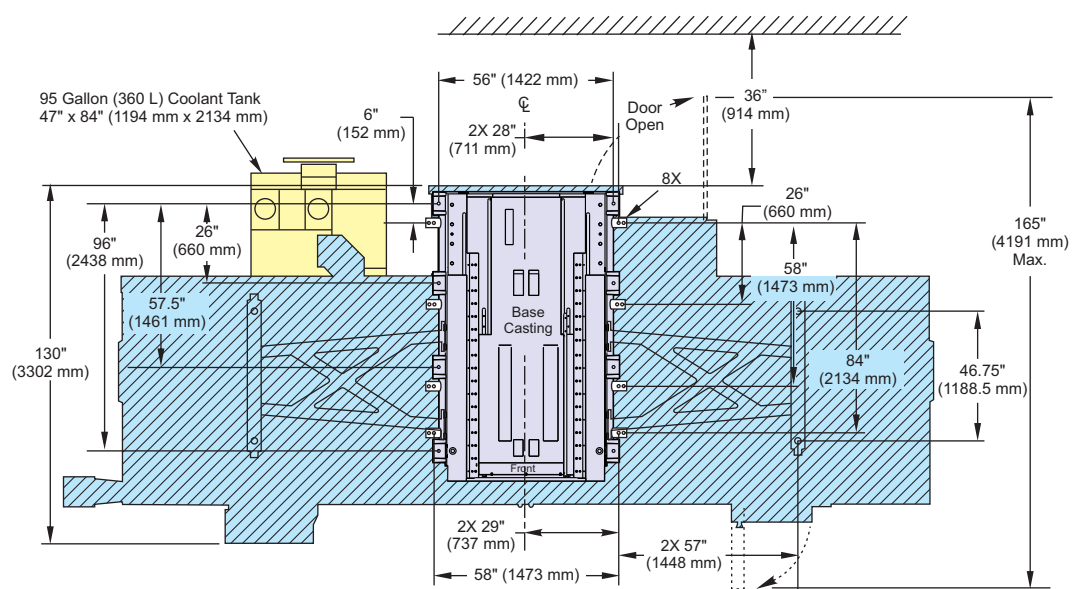
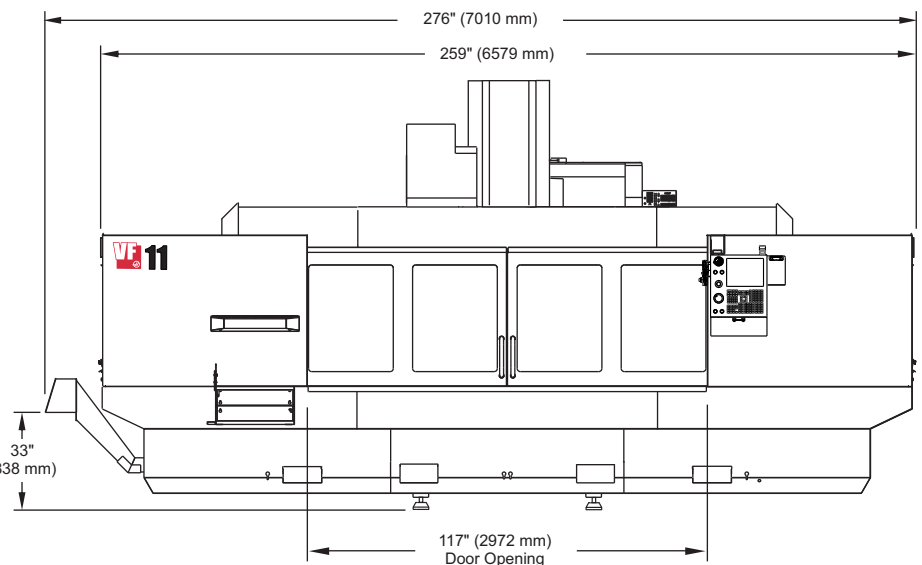

VF-11/40 Enclosure Usable Work Space

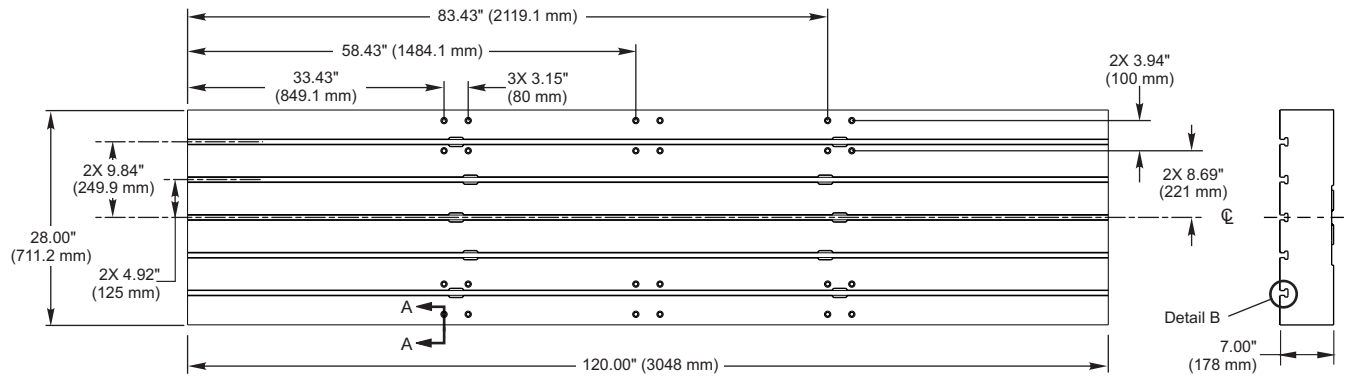

VF-11 Table Dimensions

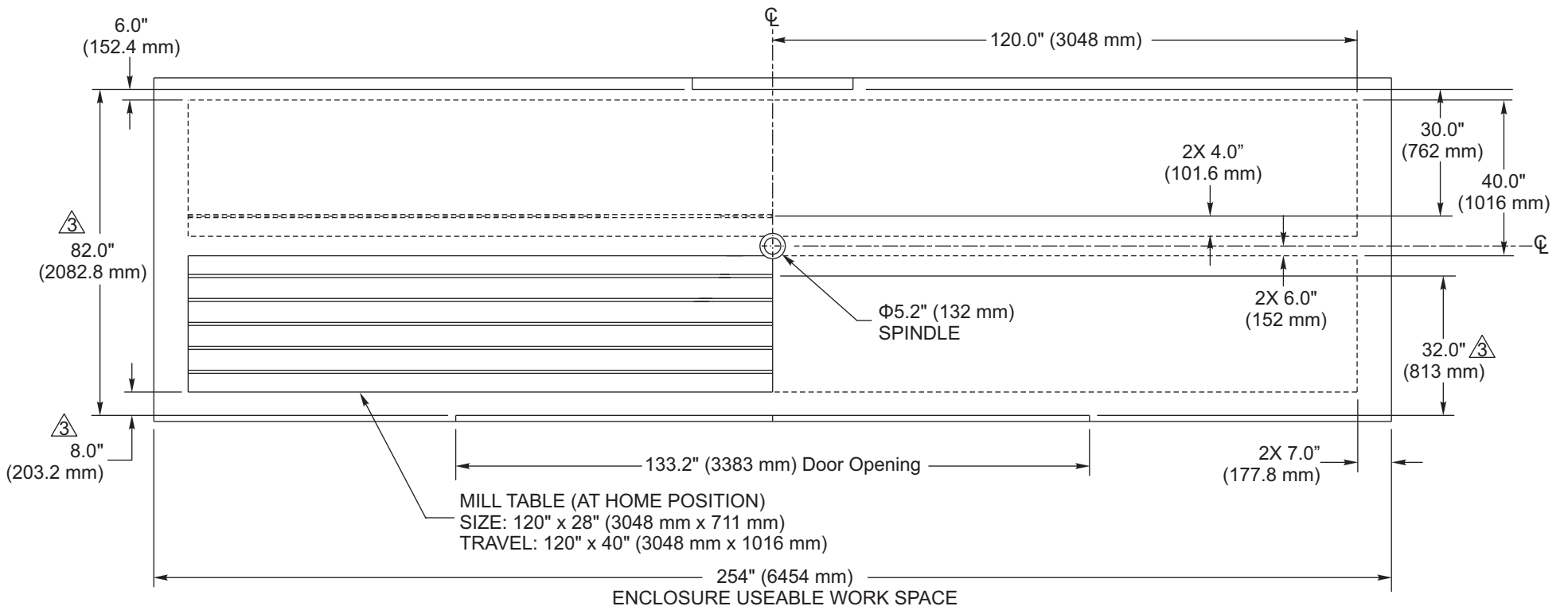
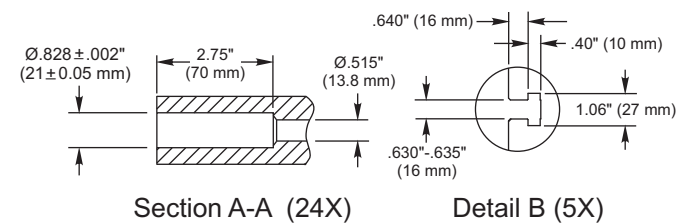

NOTES:

1. TABLE POSITION(S) AT MAX X & Y TRAVELS.
2. MEASUREMENTS ARE FROM THE EDGE OF MILL TABLE TO NEAREST OBSTRUCTION (i.e. ENCLOSURE, WAY COVER, DOORS, ETC.).
3. DIMENSIONS ARE REDUCED AS HEIGHT ABOVE TABLE INCREASES; i.e. FRONT OF ENCLOSURE IS SLOPED 5 INWARD FROM BOTTOM TO TOP. DIMENSIONS SHOWN ARE AT TABLE TOP HEIGHT.

TOP VIEW

