

TM-2/TM-2P Machine Layout Drawing

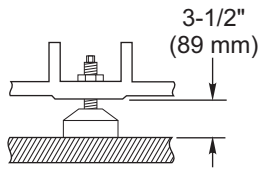

4X Leveling Pad Pin Dimension

(4X) Ø1-1/2 x 8-1/2" DP
 ((4X) Ø38 x 216 mm DP)

Note:
 Foundation must extend
 at least 1 ft. (305 mm)
 from bored holes.

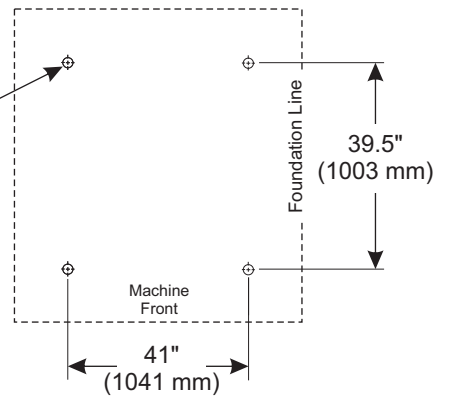

TM-2 Anchor Pattern

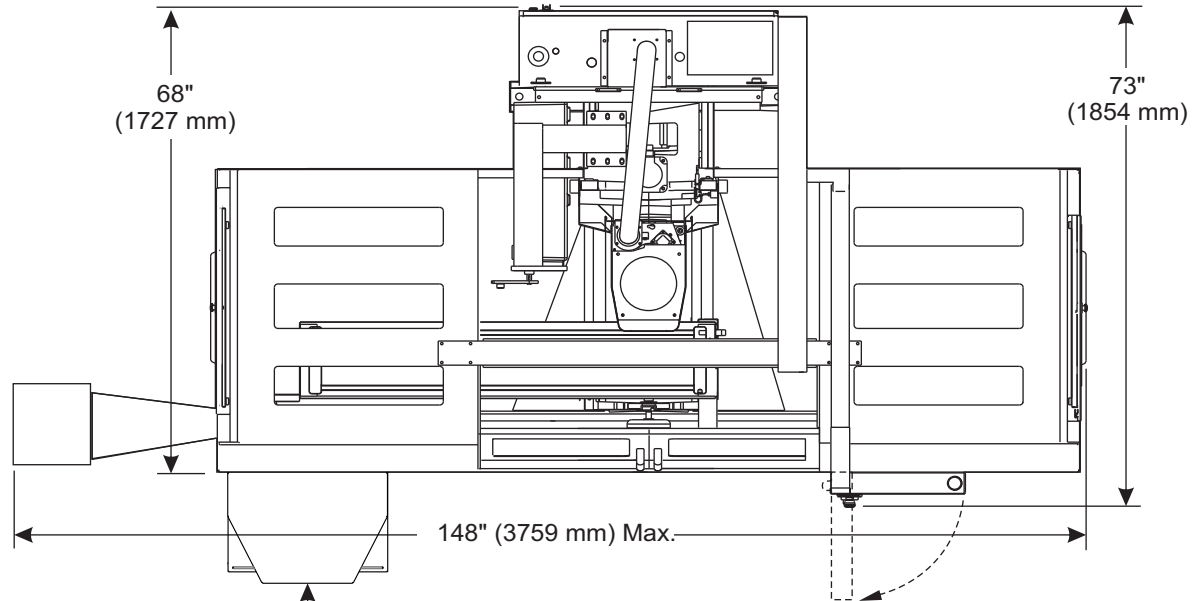
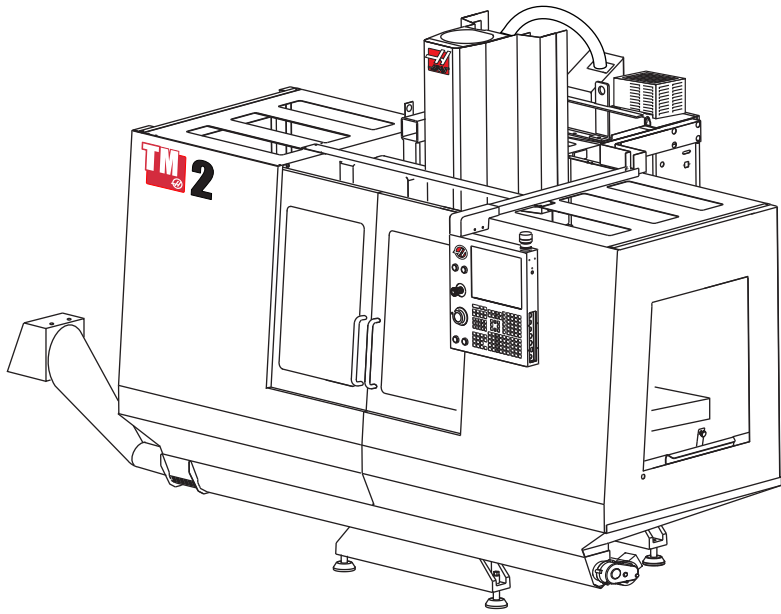

Convenience Package
 Optional on TMs
 Standard on TM-Ps

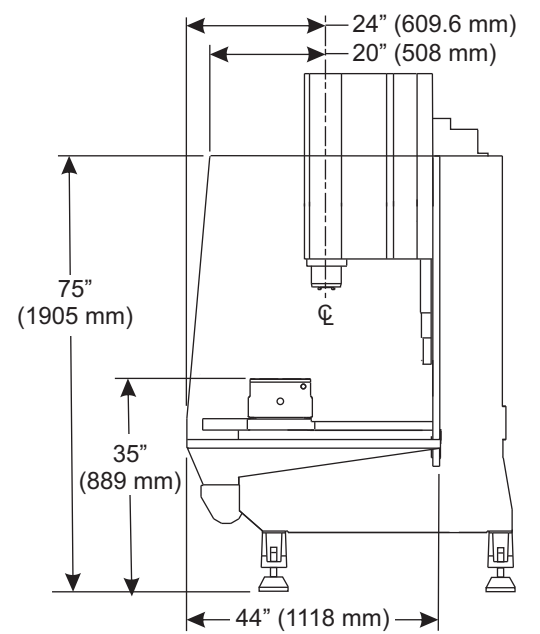
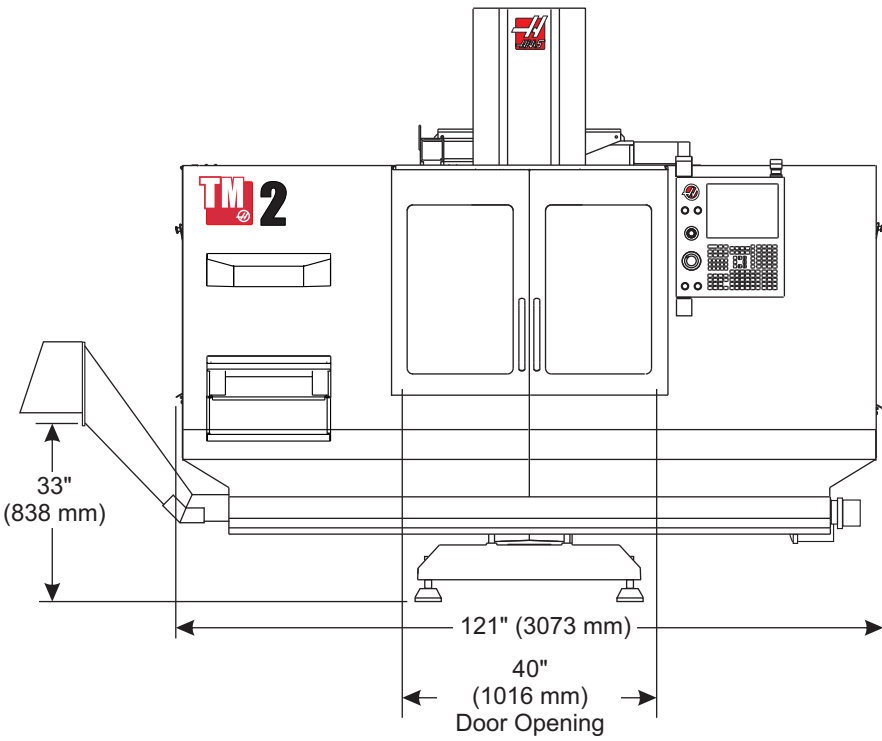

TM-2 Sheet Metal Removed for Clarity

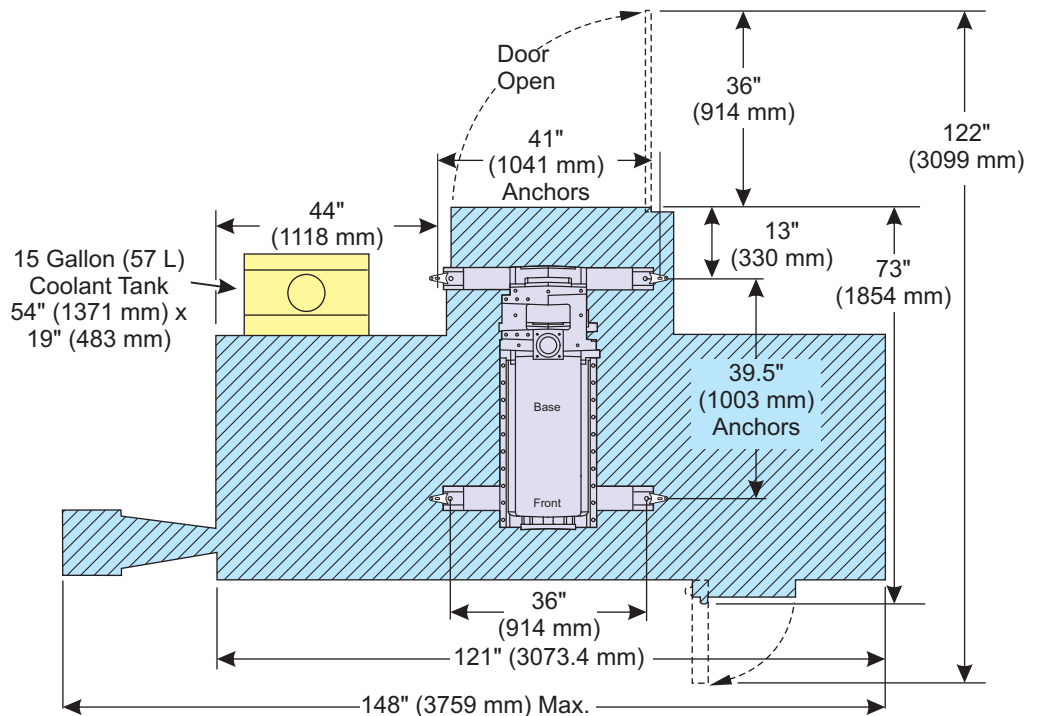
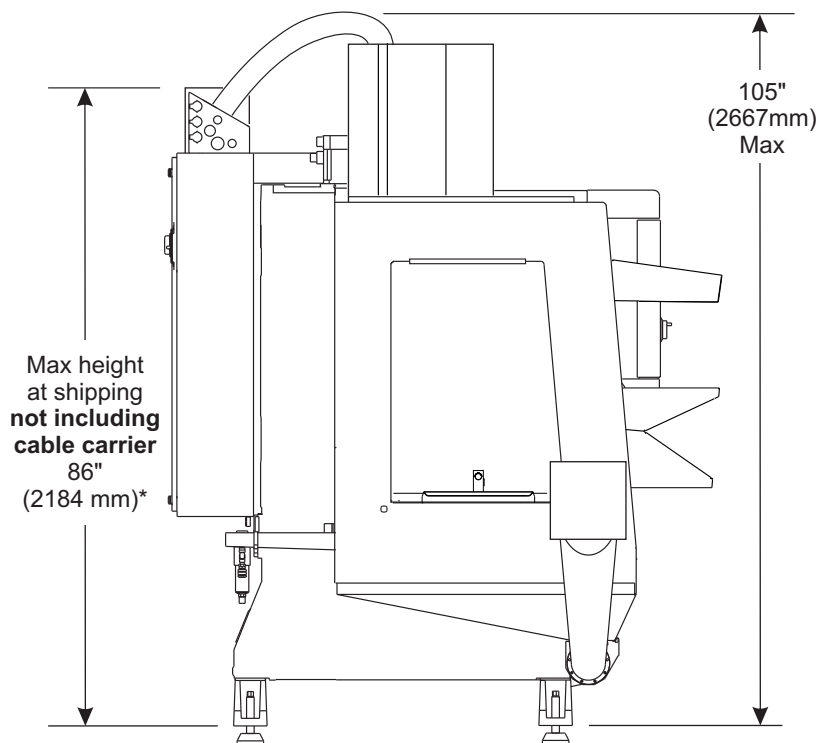

* The lowest the machine can be broken down to is 84" (2134mm) leaving the feet; 78" (1981 mm) with the feet removed

TM-2/TM-2P Machine Layout Drawing

TM-2 Enclosure Work Space

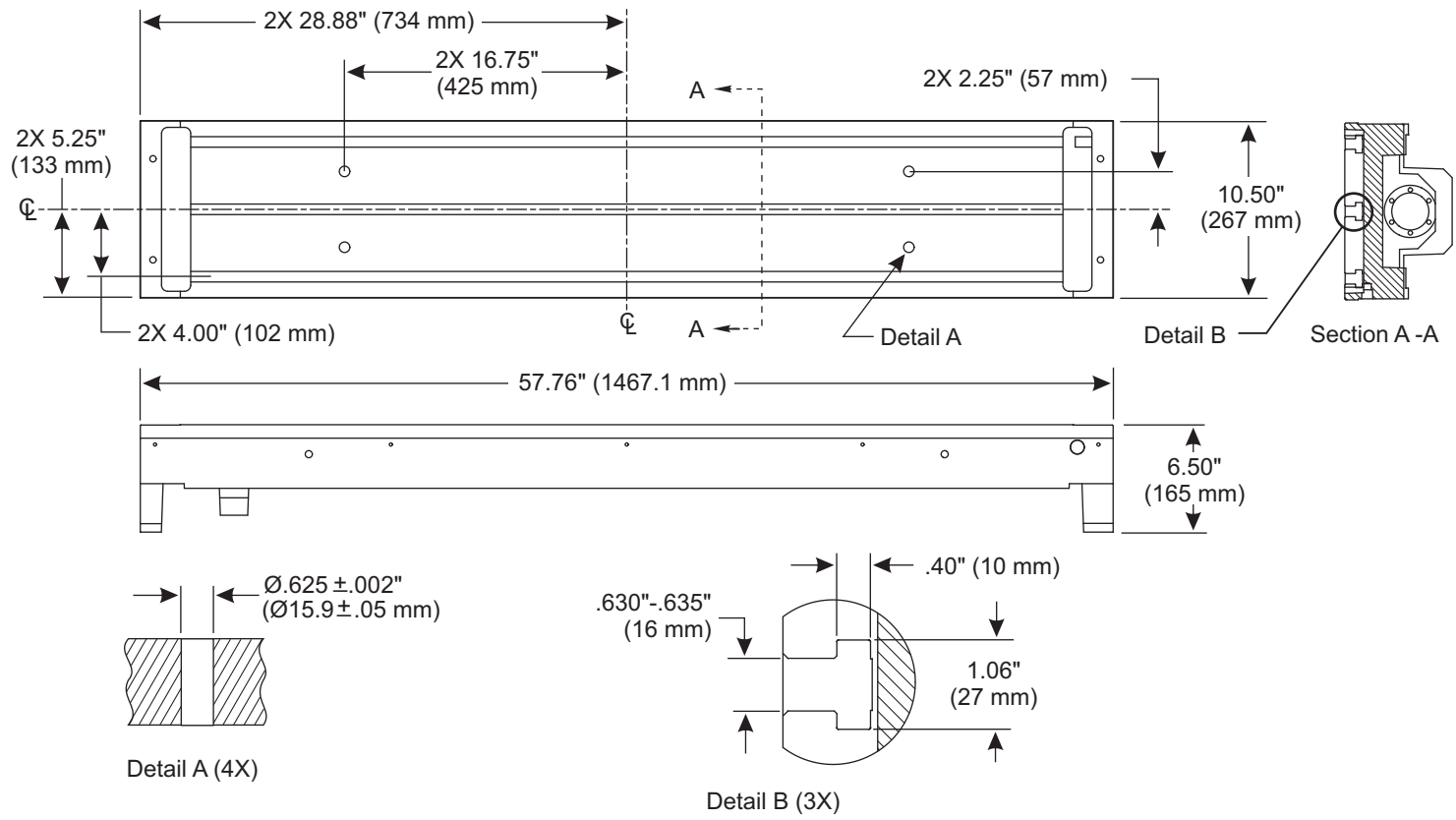

TM-2 Table Dimensions

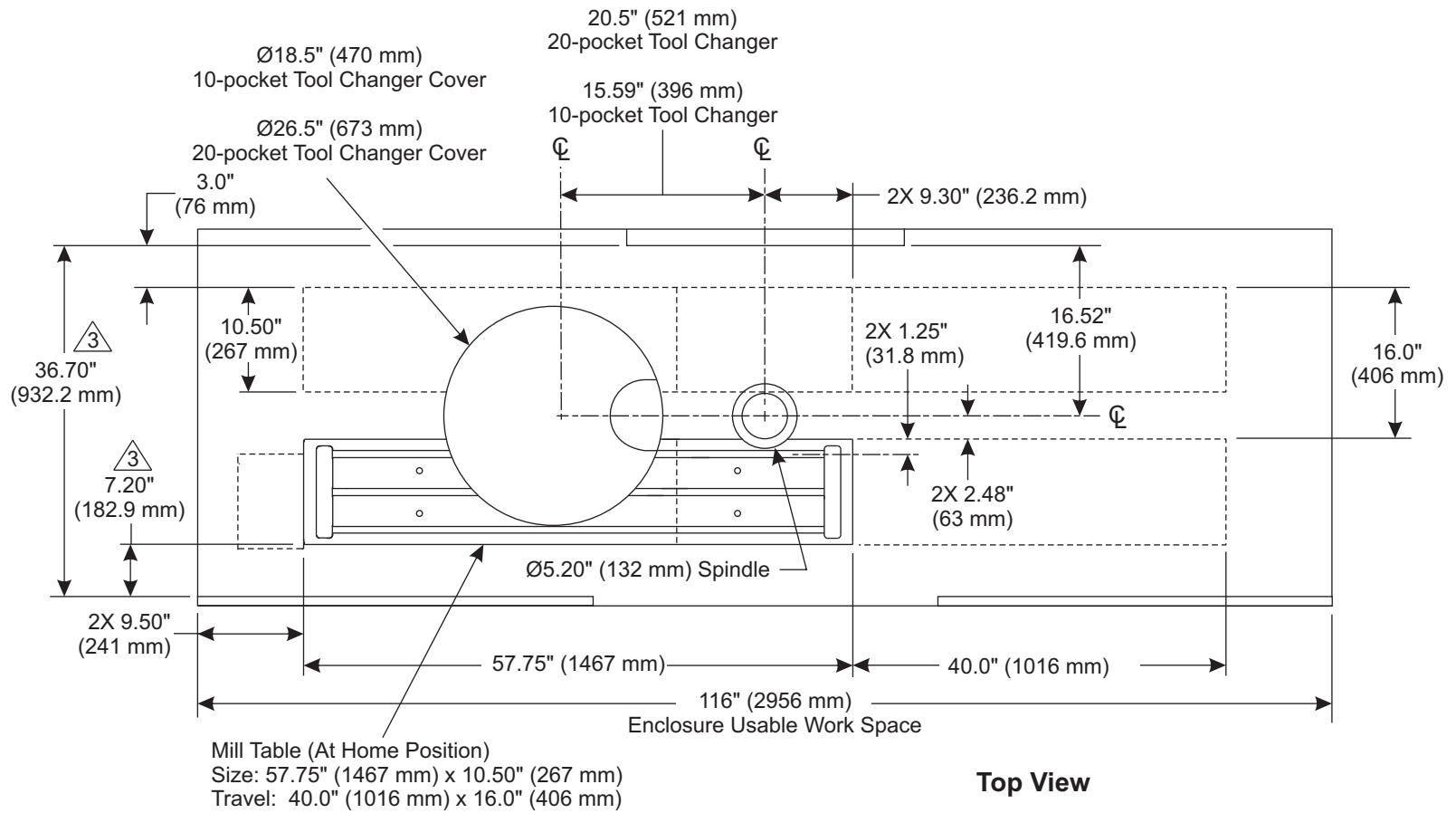

Top View

- Notes: 1. Table position(s) at max X and Y travels.
 2. Measurements are from the edge of Mill table to nearest obstruction (ie. Enclosure, Waycover, Doors, etc.).
 Dimensions are reduced as height above Table increases.
 ie. Front of enclosure is sloped 5" inward from bottom to top.
 dimensions shown are at Table top height.

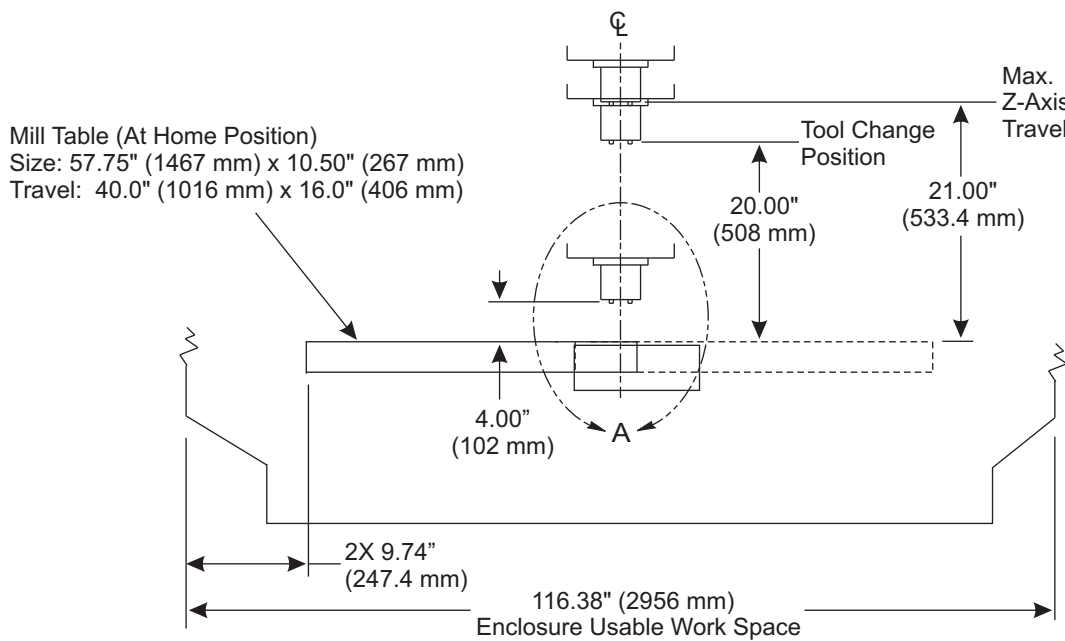

Front View

