

TL-2 Machine Layout Drawing

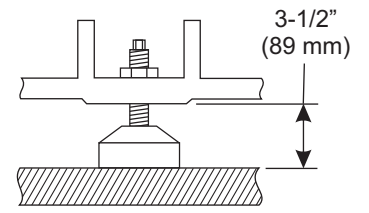

4X Leveling Pad Pin Dimension

- ① Electrical Connection
- ② Air Connection

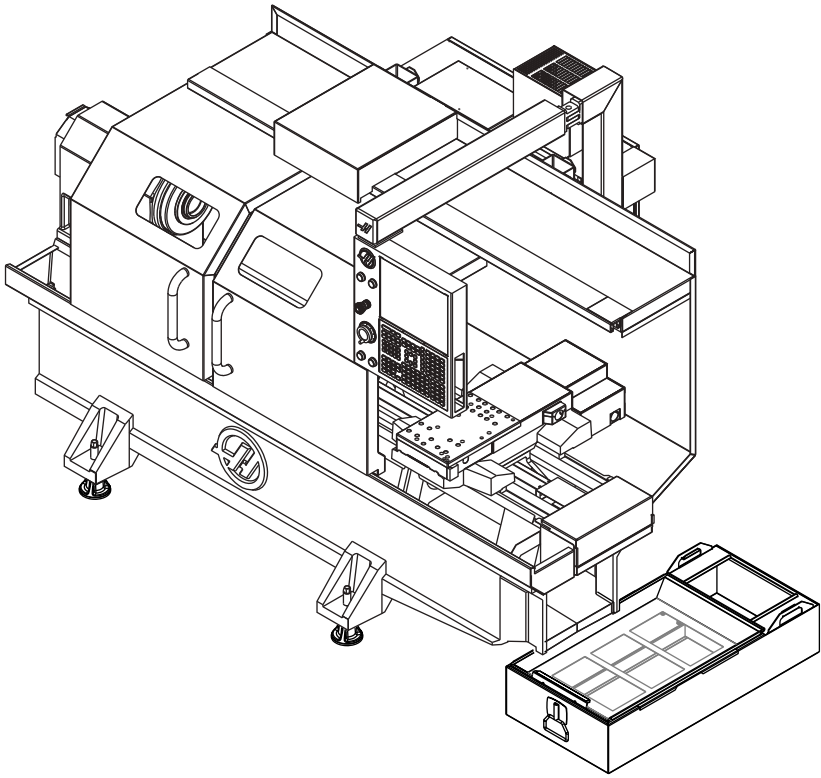
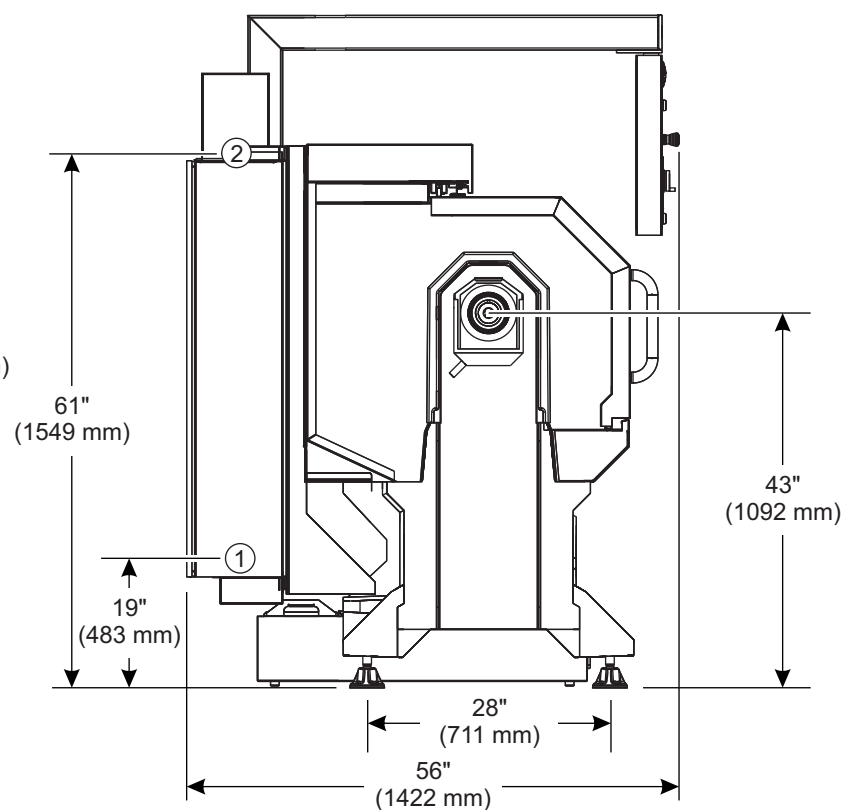
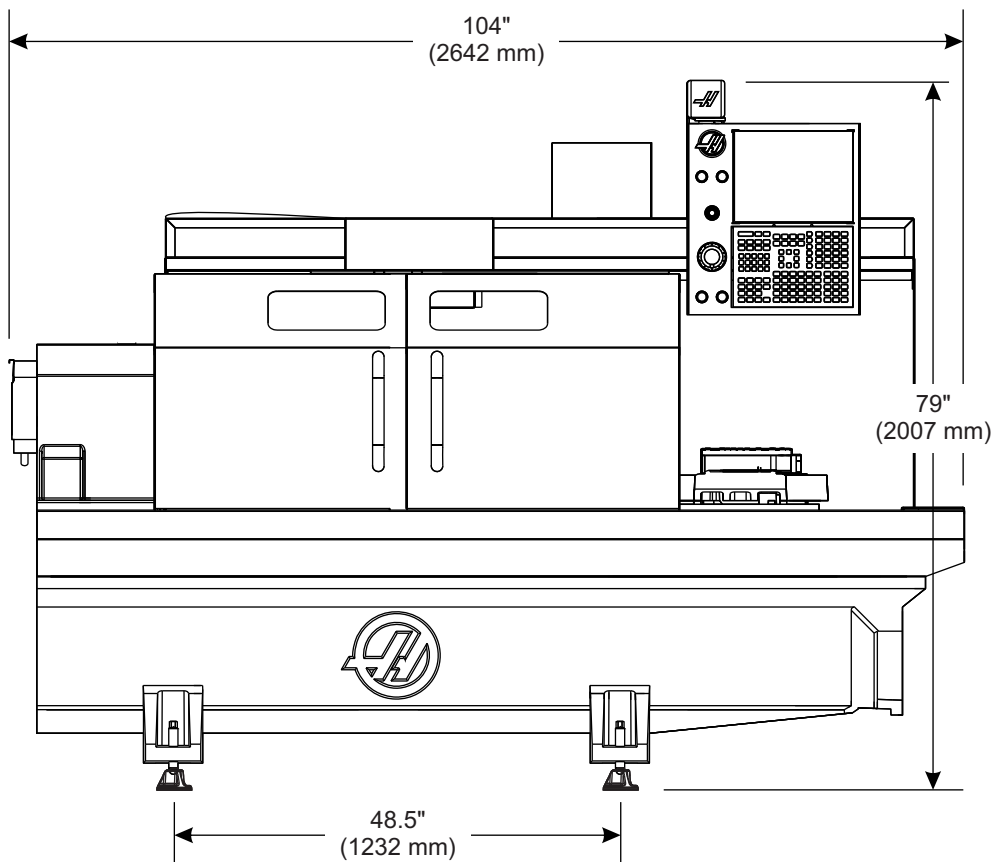
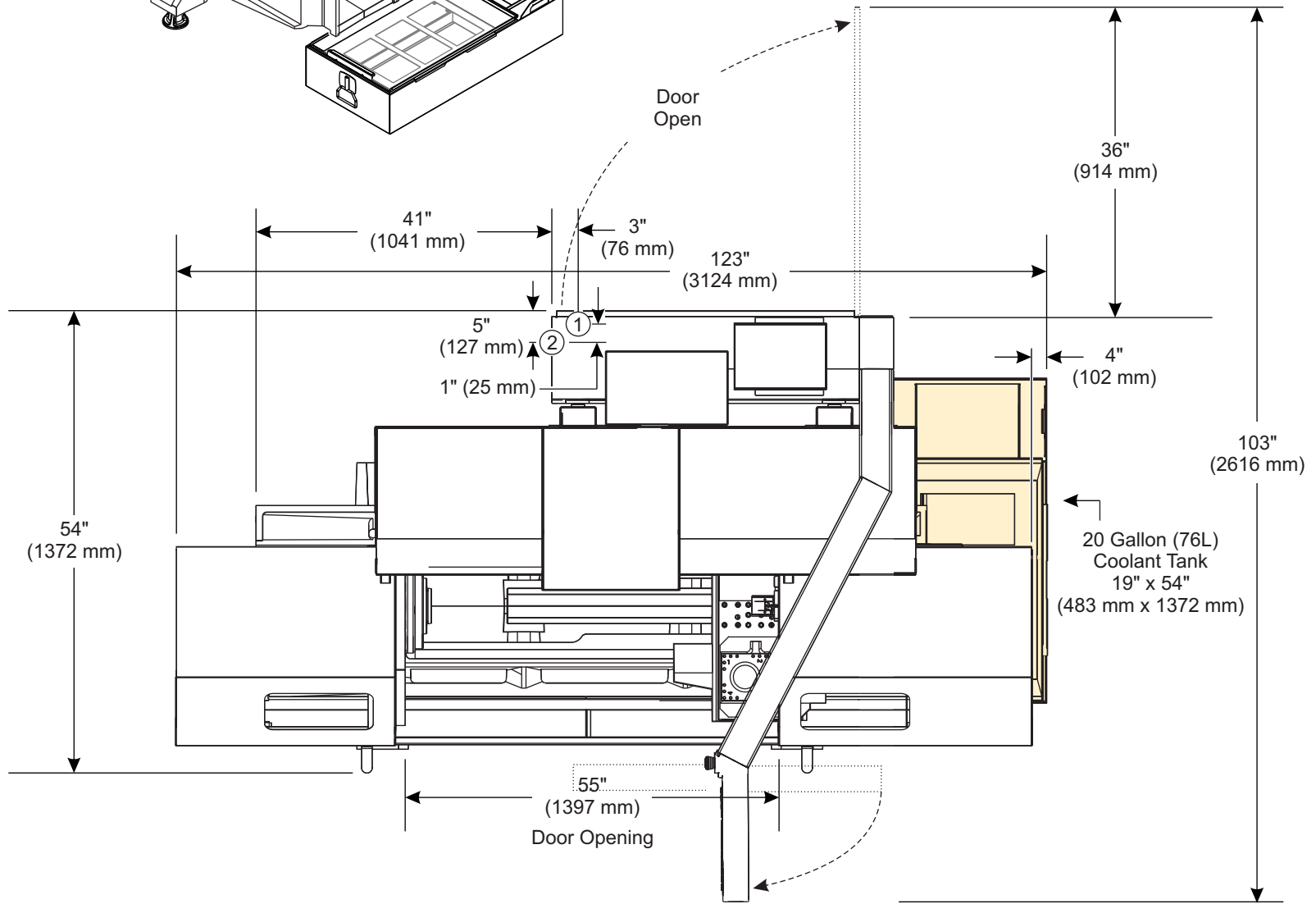

TL-2 Machine Layout Drawing

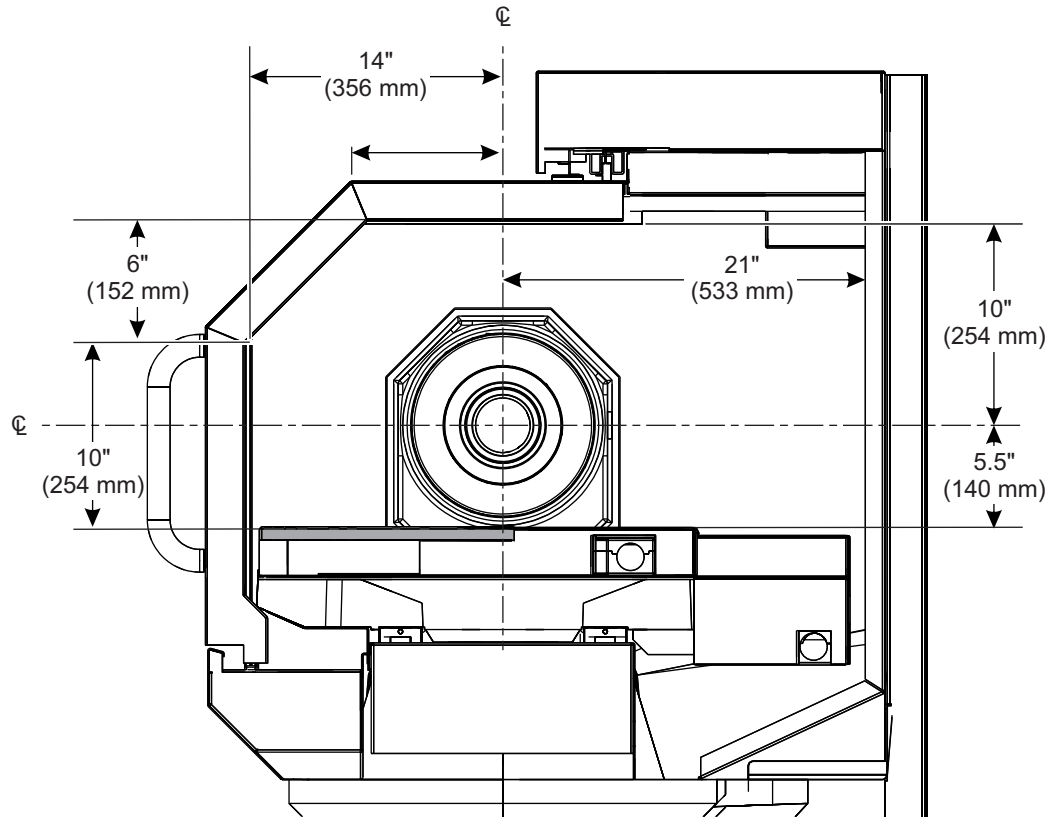

TL-2 Enclosure Work Space (Right Side)

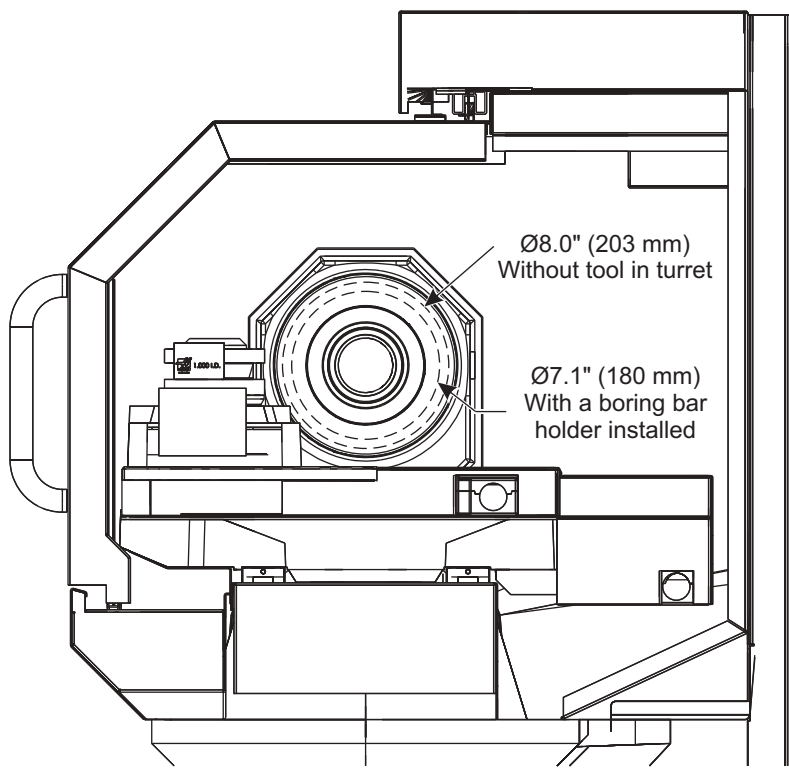

Max turning diameter with 4-station automatic tool turret

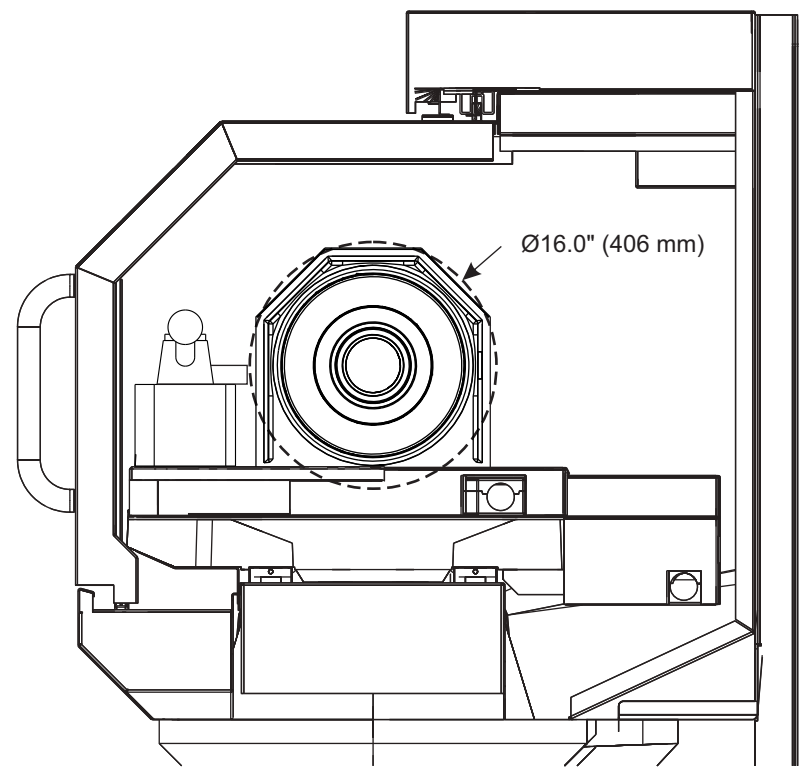

Max turning diameter with 3/4" (20 mm) tool post

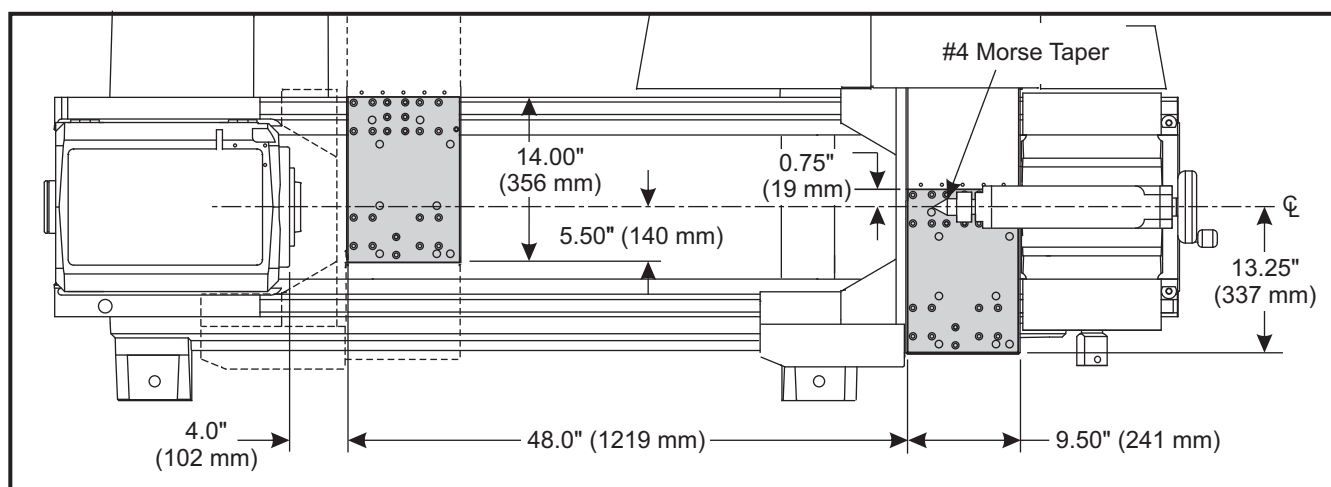

TL-2 Enclosure Work Space (Top View)

TL-2 Machine Layout Drawing

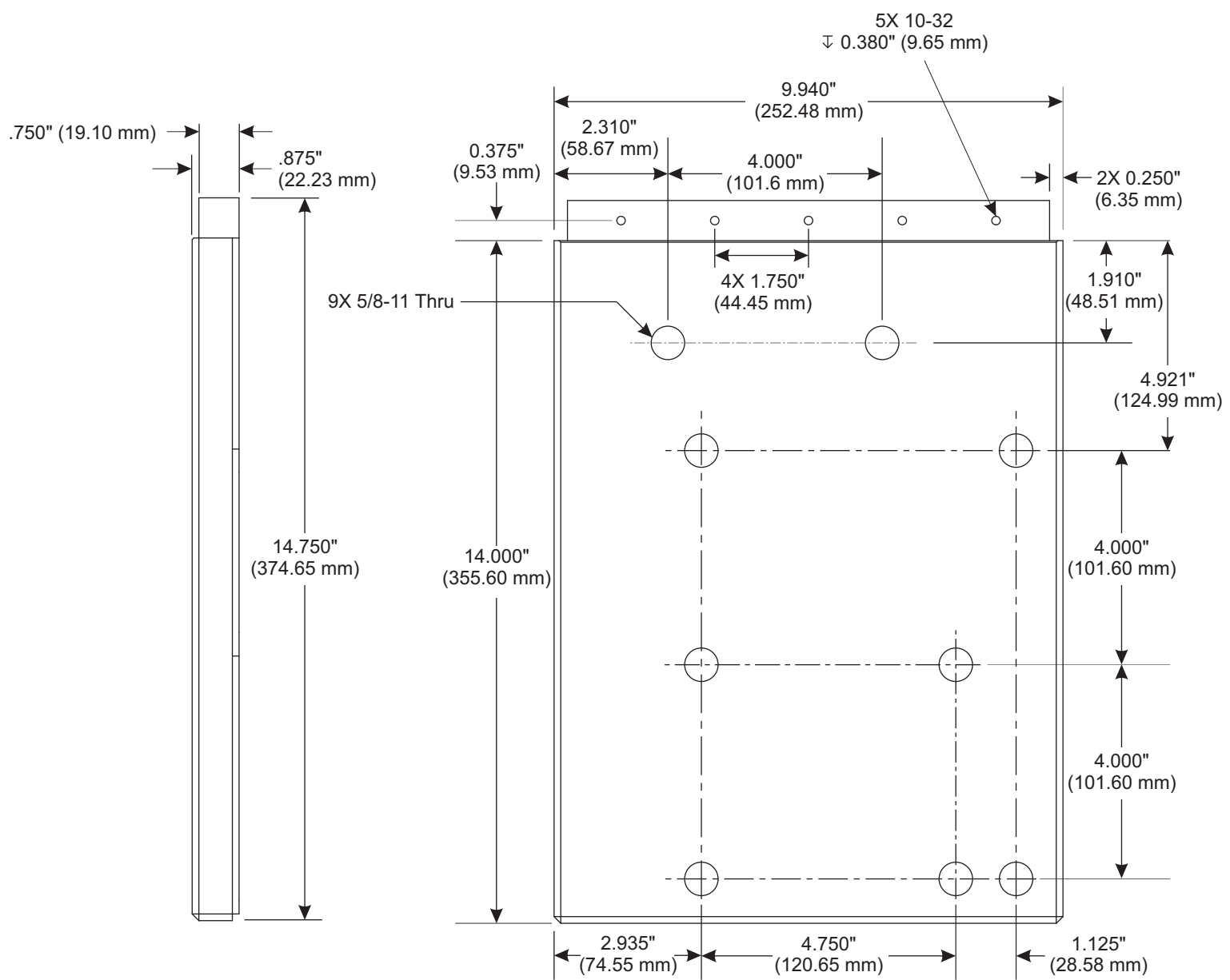

TL-2 Cross Slide Dimensions