

6X Leveling Pad Pin Dimension

- ① Electrical Connection
- ② Air Connection

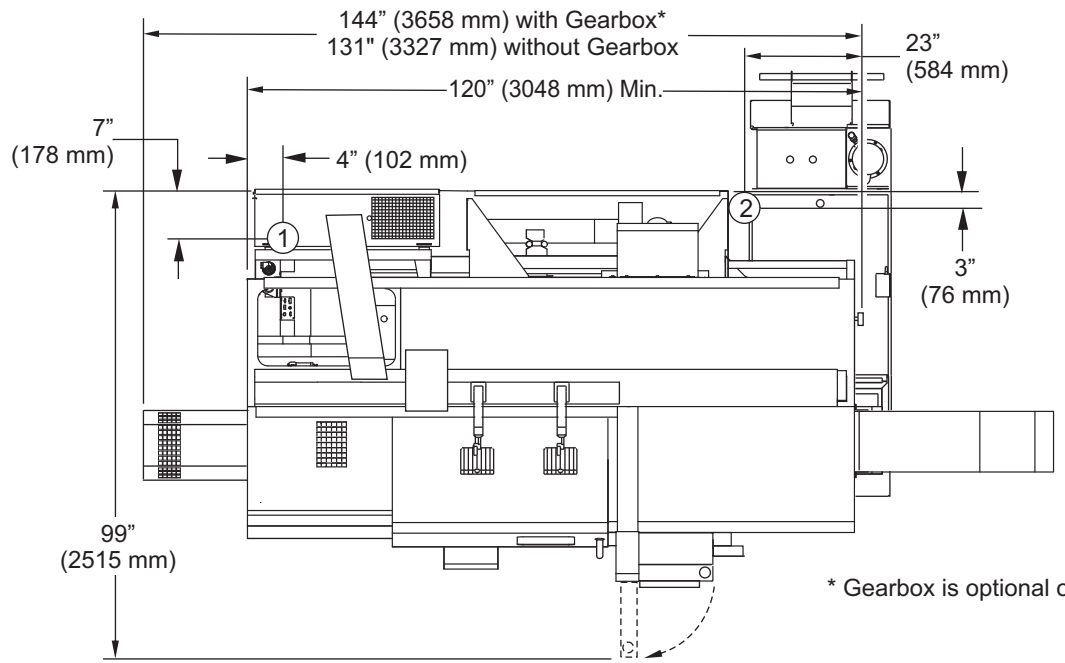

* Gearbox is optional on ST-30Y/35Y

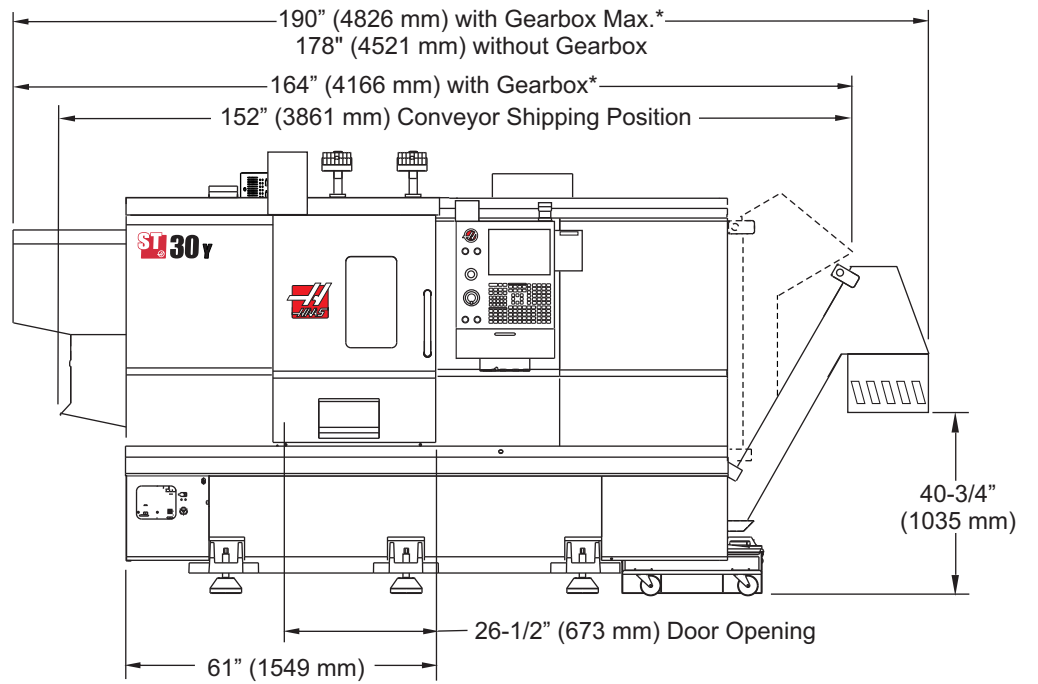
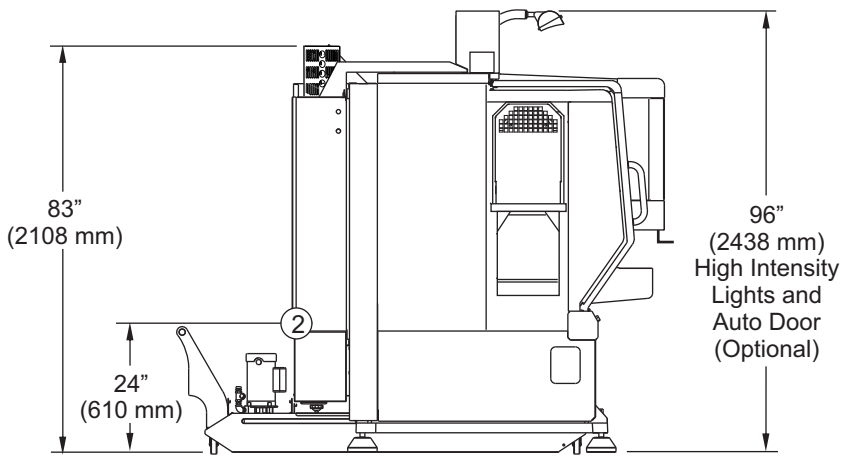

Minimum distance required to remove conveyor from lathe 134" (3404 mm).

Minimum distance required to remove conveyor from lathe 88" (2235 mm) when conveyor is folded at 90 degrees and folded down as it is pulled out.

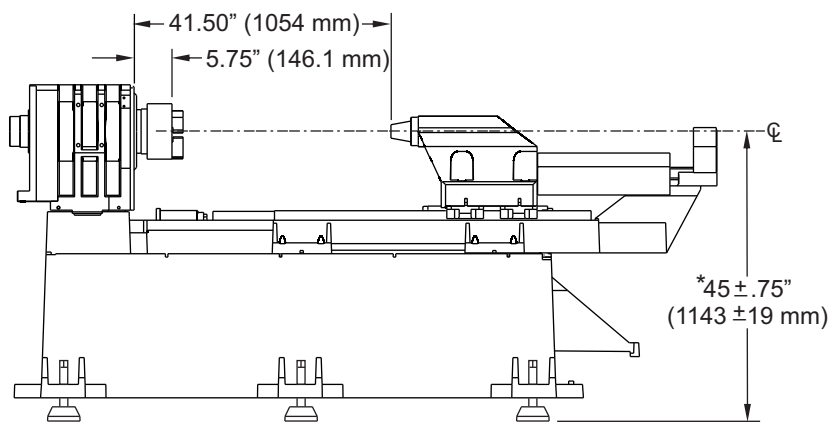
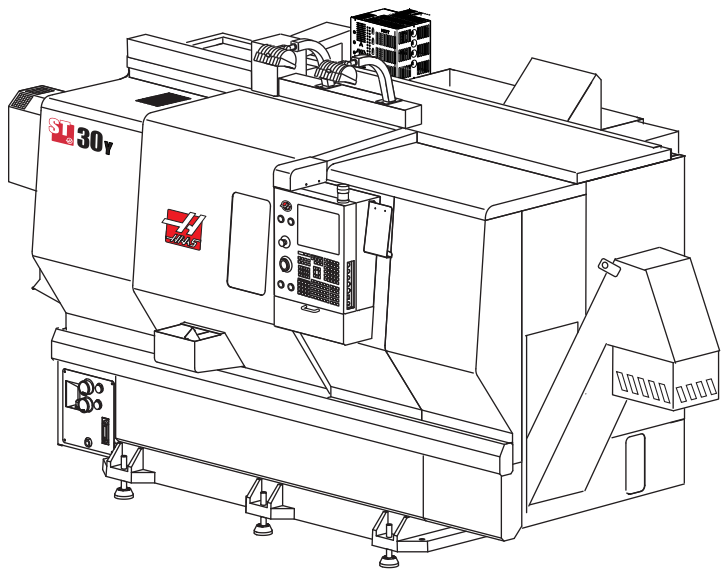

*Spindle center heights from floor, may vary due to leveling screw adjustments.

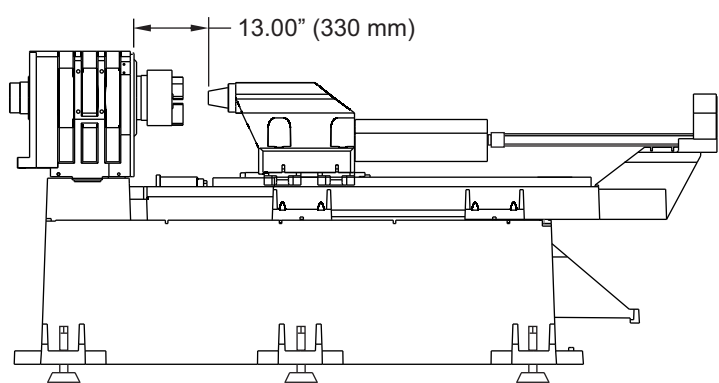

ST-30Y/35Y Tailstock Travel #4 Morse Taper

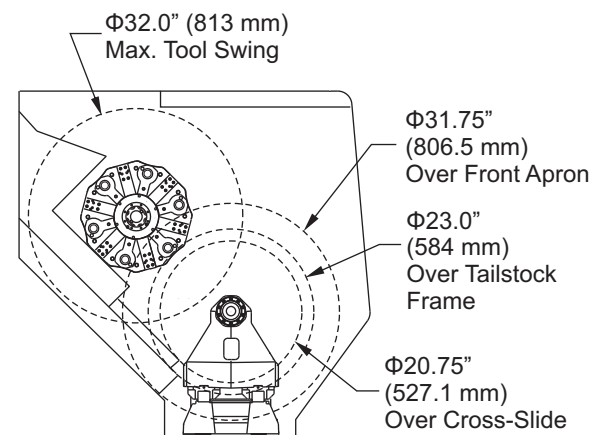
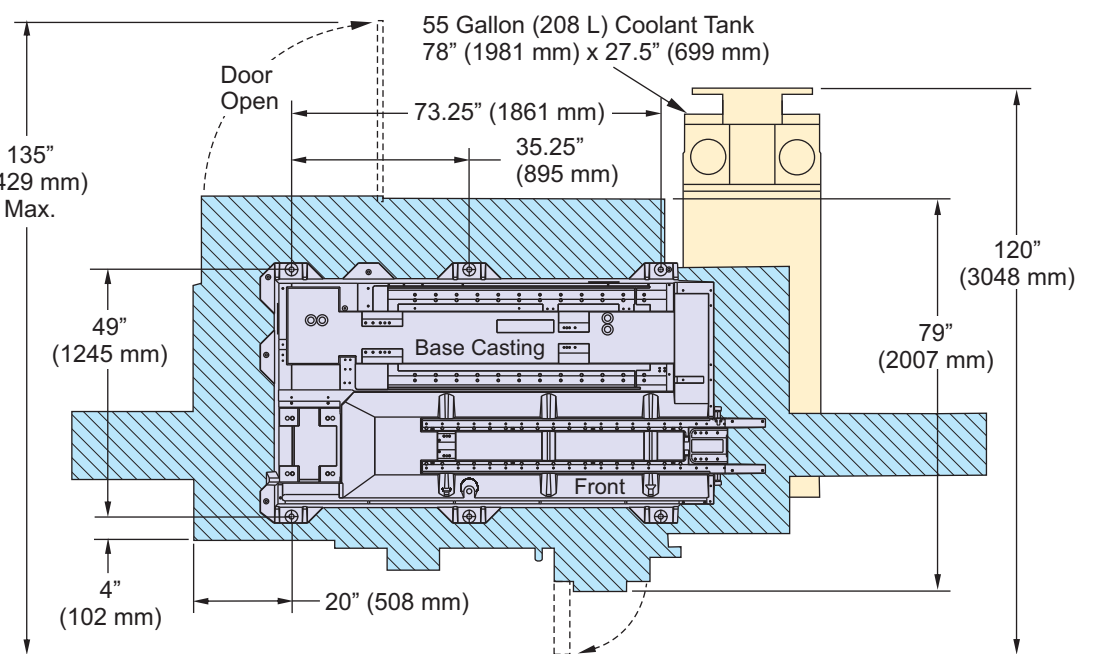

ST-30Y/35Y Tool Swing Envelope Turret at Home Position 12-Station Hybrid VB12 Turret Standard

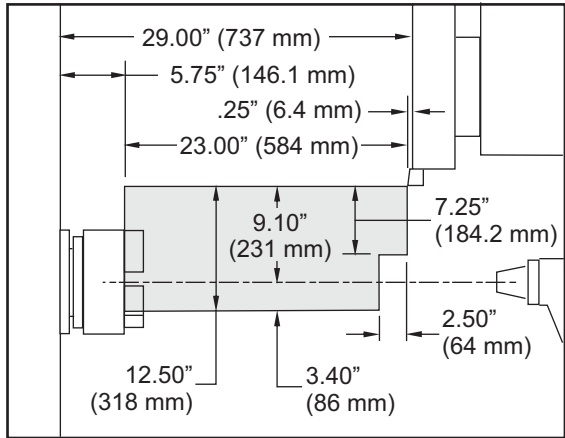
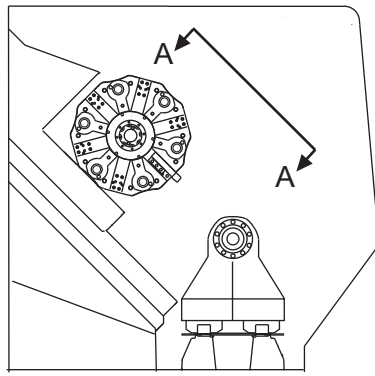

VB12 OD

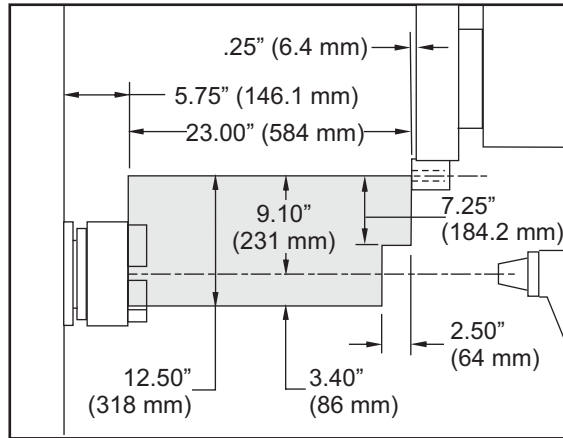

VB12 BOT ID

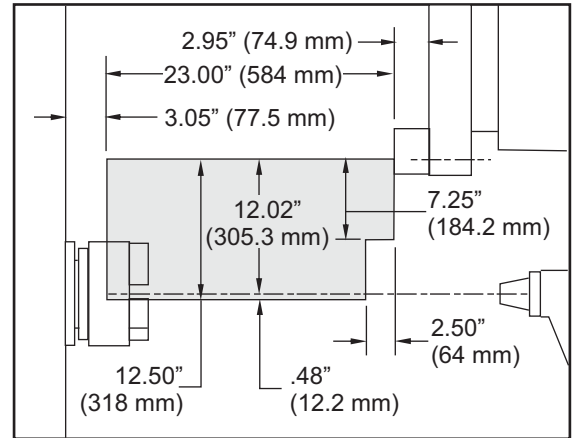

VDI ID, VB12 VDI ID

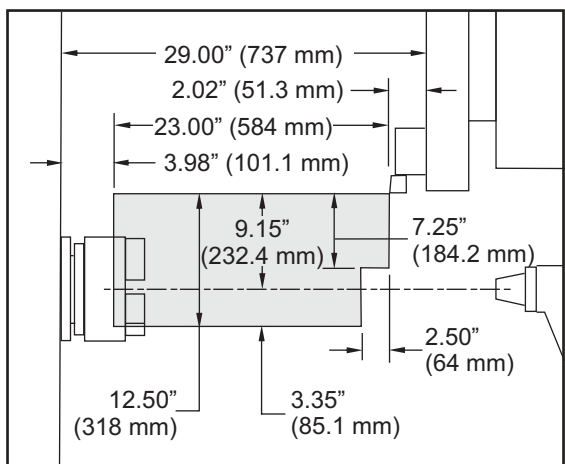

VDI OD, VB12 VDI OD

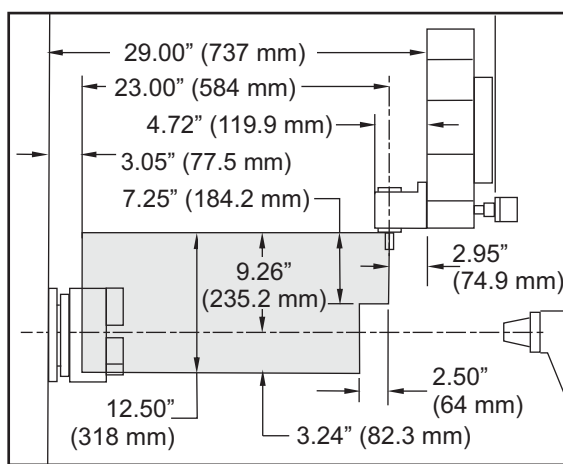

LIVE RADIAL TOOL

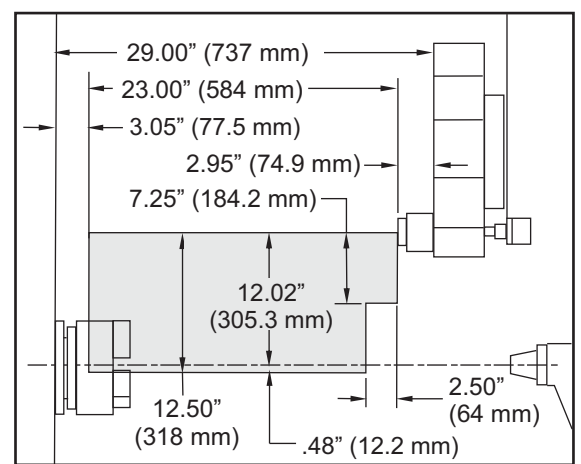

LIVE AXIAL TOOL

View A-A ST-30Y/35Y Cut Envelope Diagrams

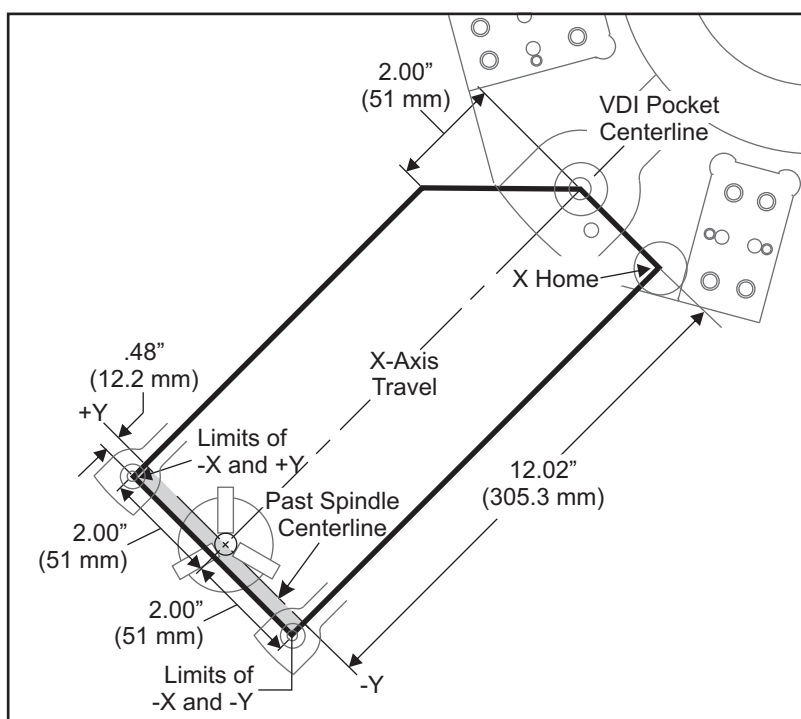

Y-Axis Travel Envelope

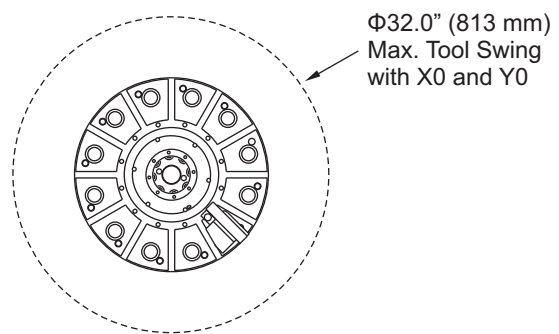

12-Station VDI Turret Option

Note:
Max. Tool Swing when
Y-2.00" (51 mm) is
29.0" (737 mm)

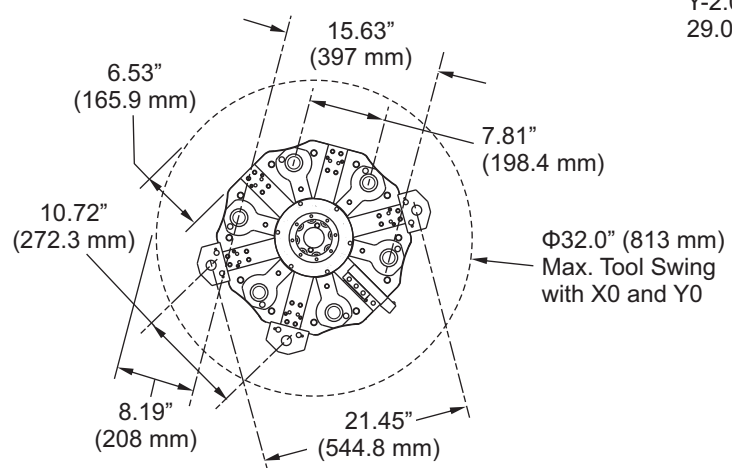

12-Station Hybrid VB12 Turret Standard

The position of the work envelope will shift when using Live Radial tools. The length the cutting tool extends from the centerline of the tool pocket is the distance the envelope shifts. The above illustration demonstrates the work envelope in relation to the center of the VDI tool pocket.

ST-30Y/35Y Tool Interference Drawings