

4X Leveling Pad Pin Dimension

- ① Electrical Connection
- ② Air Connection

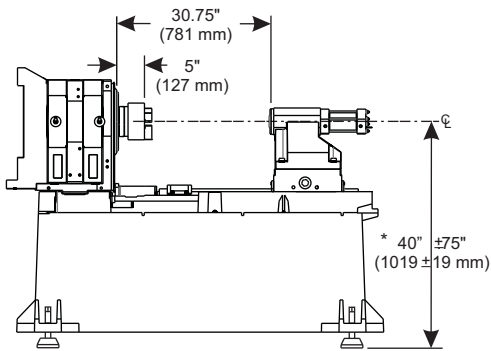

* Spindle center heights from floor, may vary due to leveling screw, which should be 3.5" (89 mm) from base to floor.

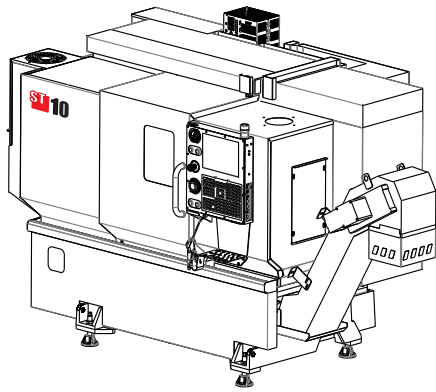
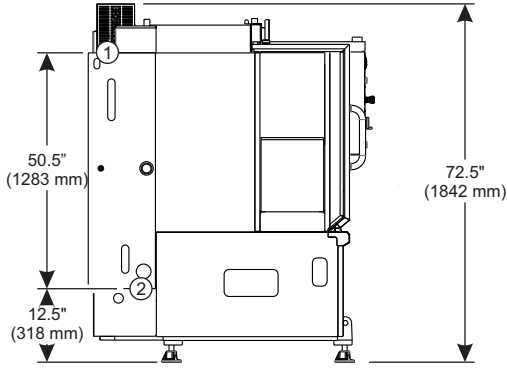
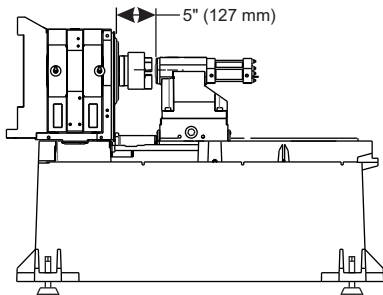

Tailstock Body Travel
#3 Morse Taper
Quill Travel: 4" (102 mm)

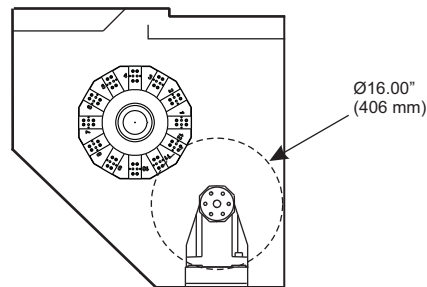
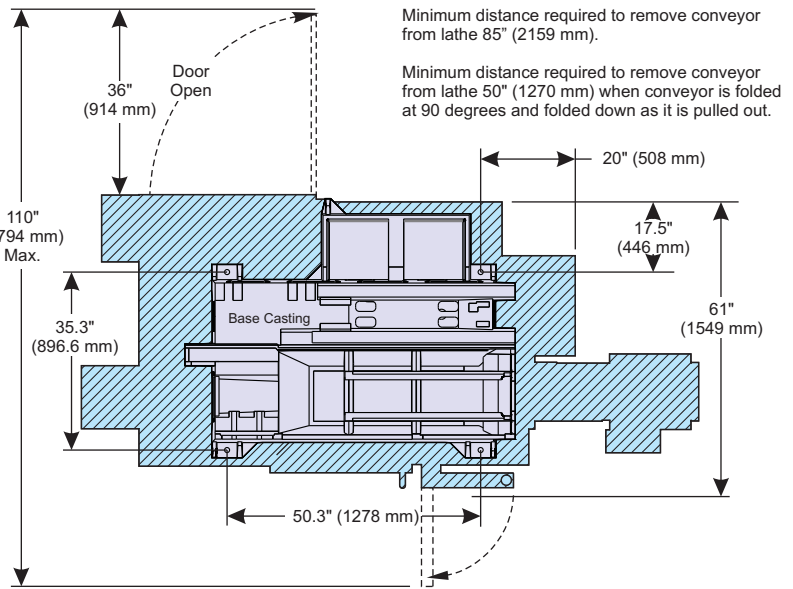
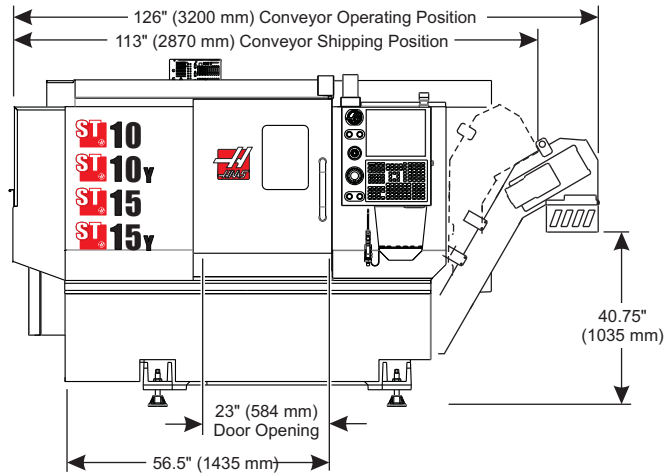
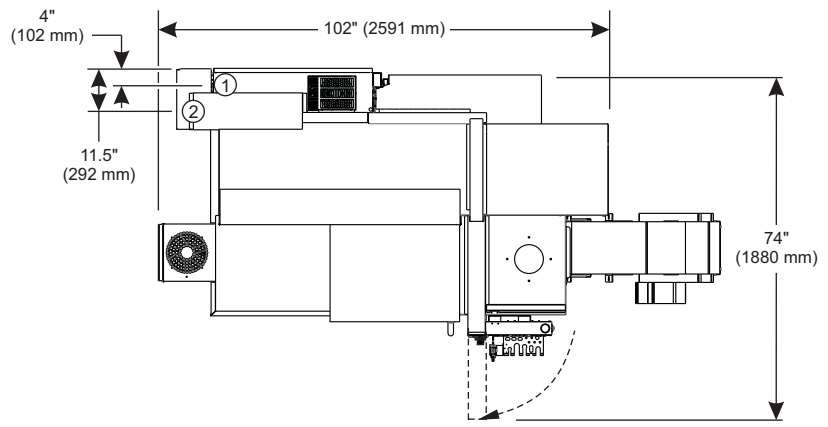

Part Swing Envelope

View A-A Cut Envelope Diagrams
(Looking at X-Plane)

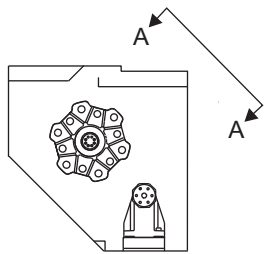

Assume short VDI holder on inner VDI pockets

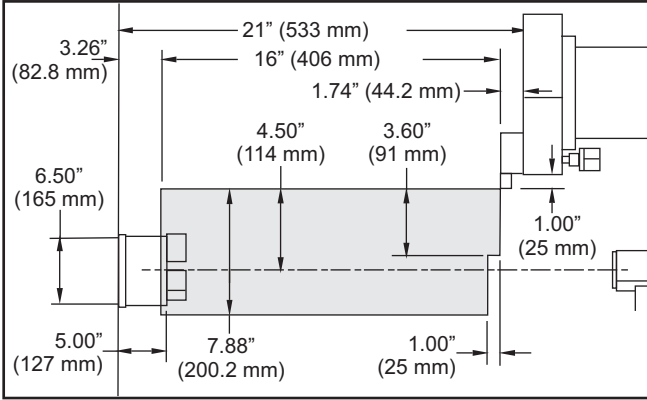

VDI OD TOOL

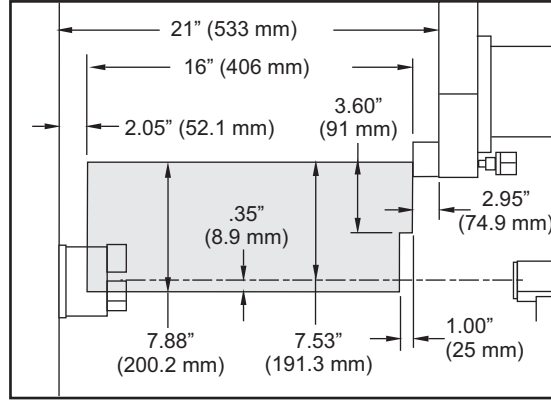

VDI ID TOOL

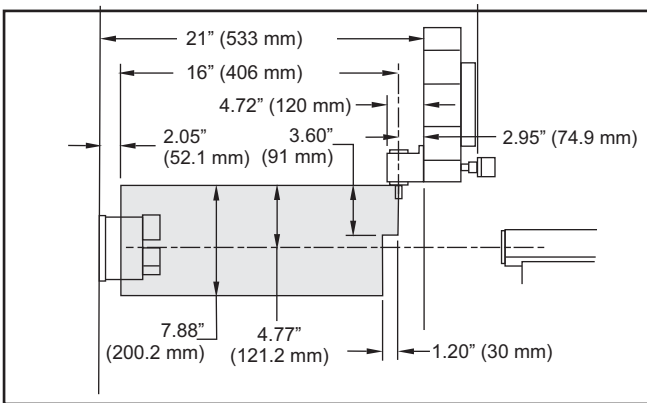

LIVE RADIAL TOOL

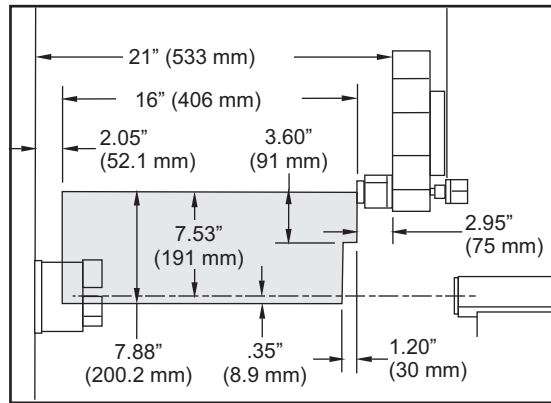

LIVE AXIAL TOOL

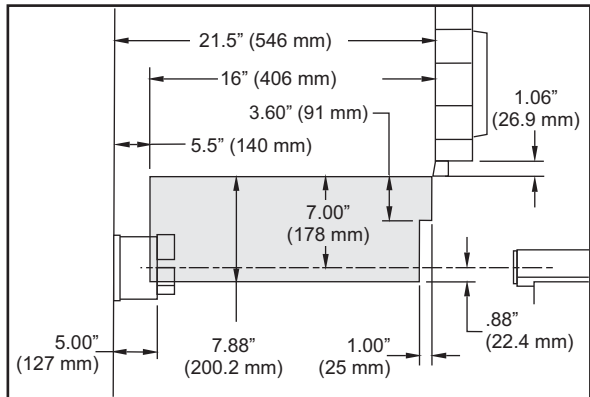

BOT OD TOOL

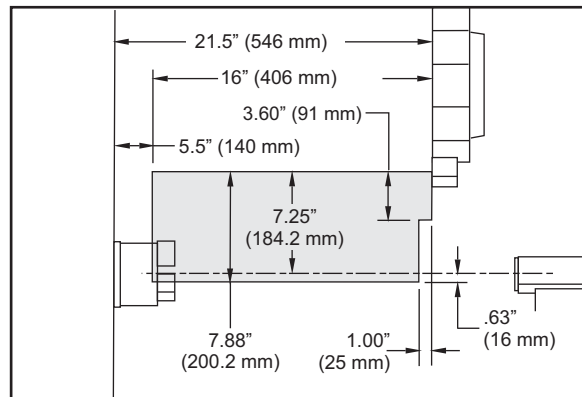

BOT ID TOOL

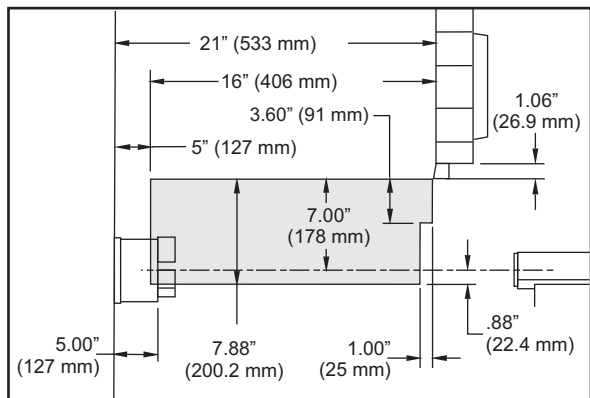

VB (BOT) OD TOOL

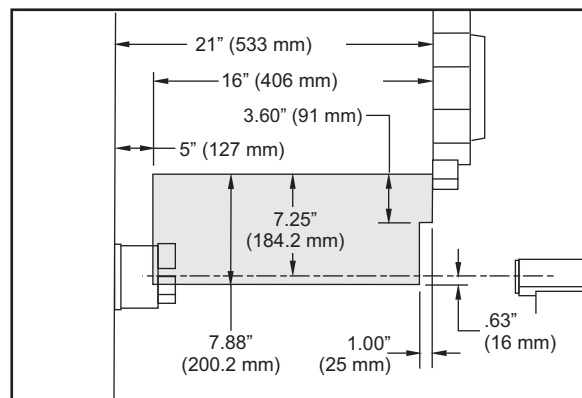

VB (BOT) ID TOOL

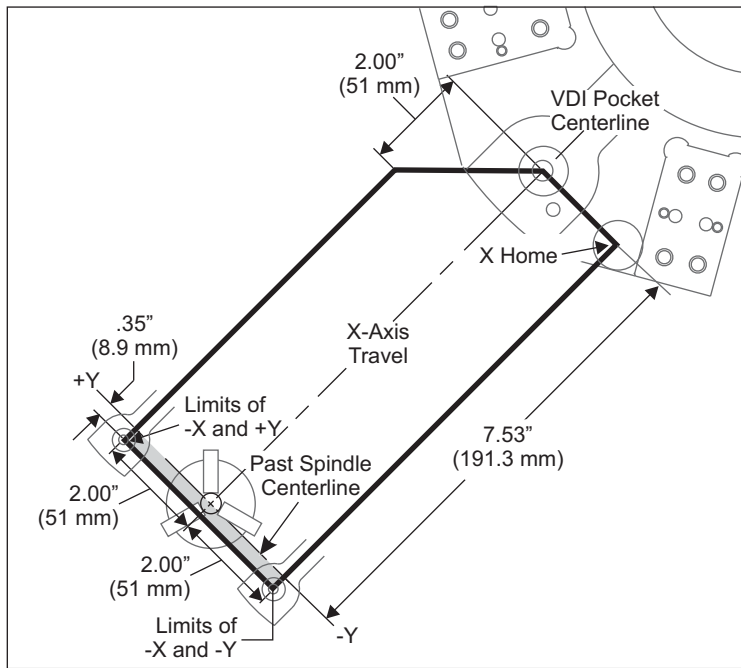

The position of the work envelope will shift when using Live Radial tools. The length the cutting tool extends from the centerline of the tool pocket is the distance the envelope shifts. The above illustration demonstrates the work envelope in relation to the center of the VDI tool pocket.

Y-Axis Travel Envelope

Tool Interference Drawings

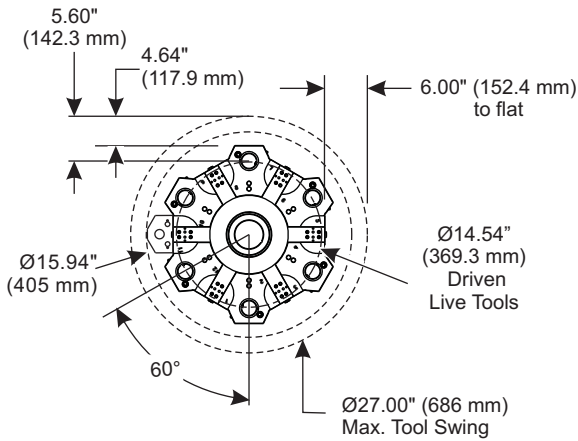

12-Station VB Turret Option

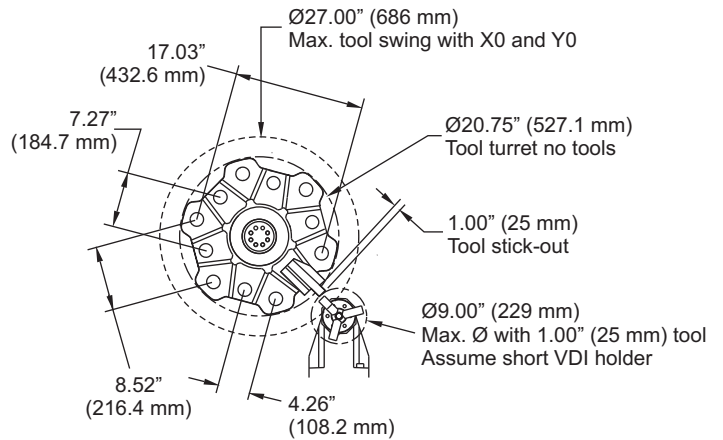

12-Station VDI Turret Standard
When X and Y at Home Position

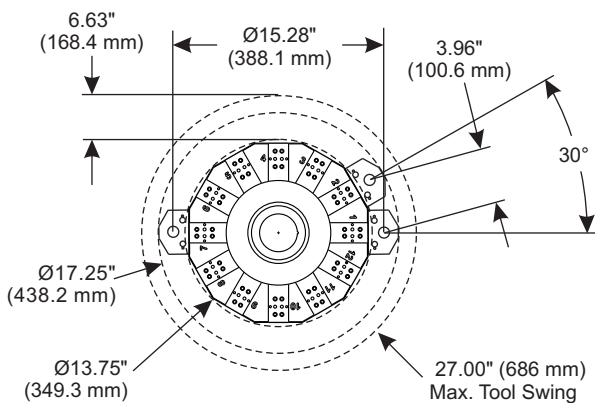

12-Station BOT Turret Standard

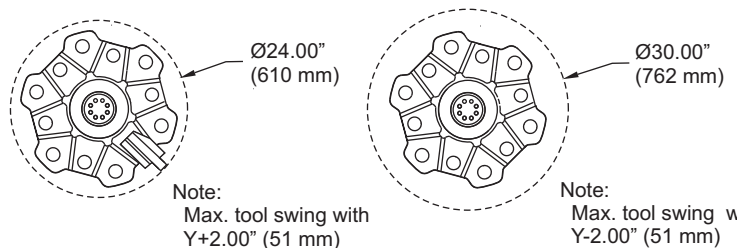

Note:
Max. tool swing with
Y+2.00" (51 mm)

Note:
Max. tool swing with
Y-2.00" (51 mm)