

HRT450 Machine Layout Drawing

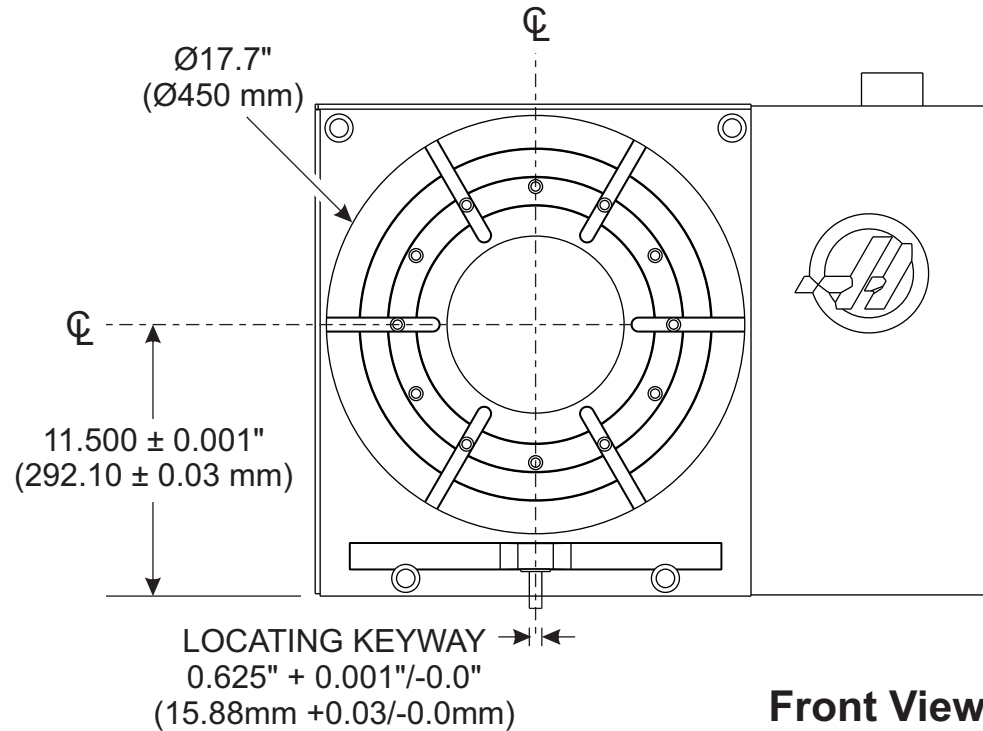

HRT450 Machine Layout Drawing

HRT450 Platter Dimensions

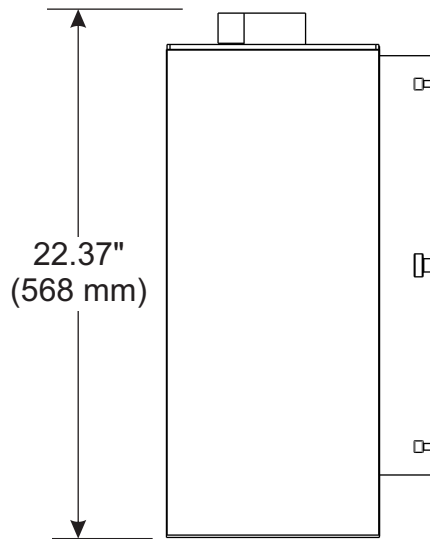
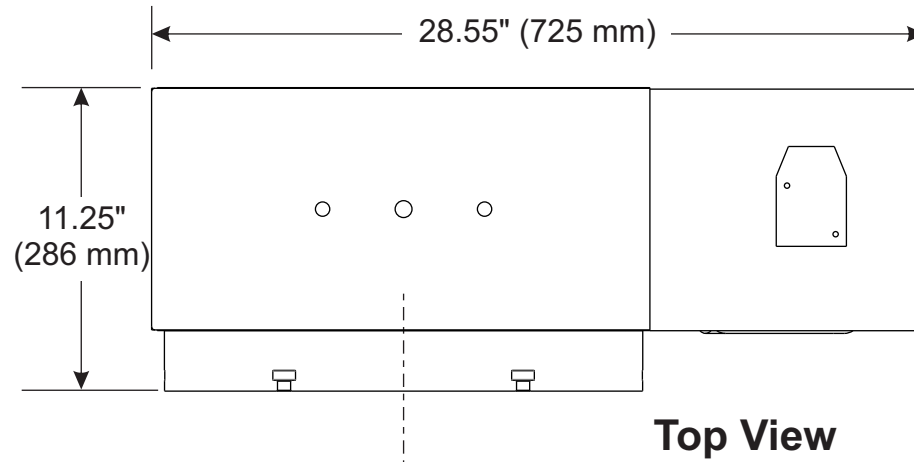
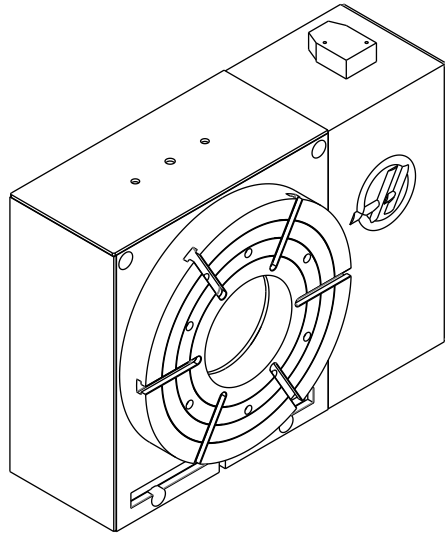
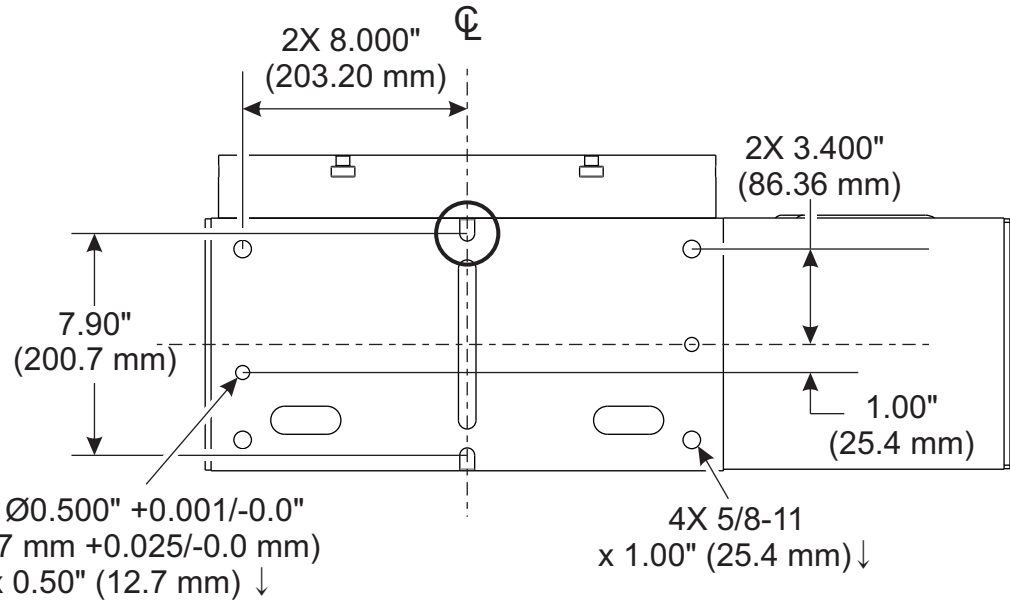
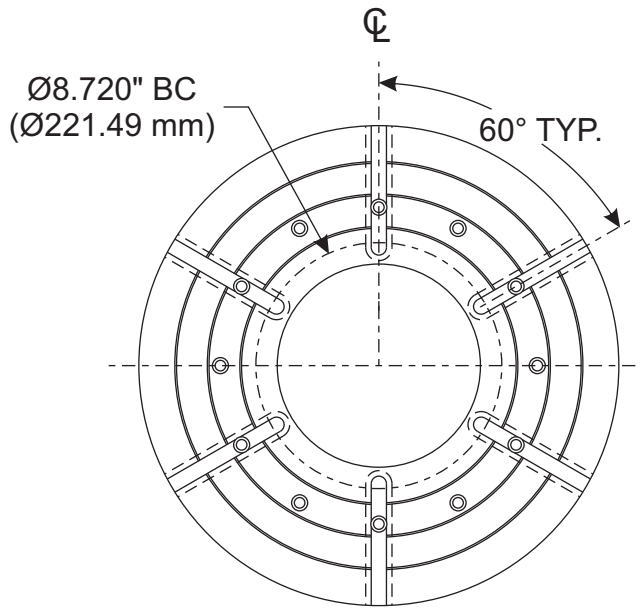

Through Hole
 $\text{Ø}7.500'' +0.001''/-0.0''$
 $\text{Ø}190.50 \text{ mm} +0.03 \text{ mm}/-0.0 \text{ mm}$

Bottom View

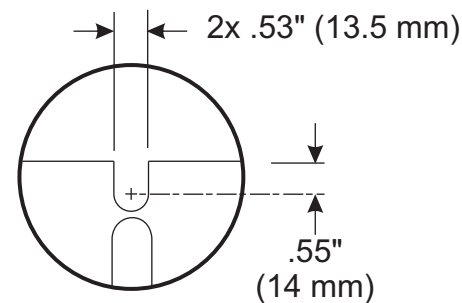
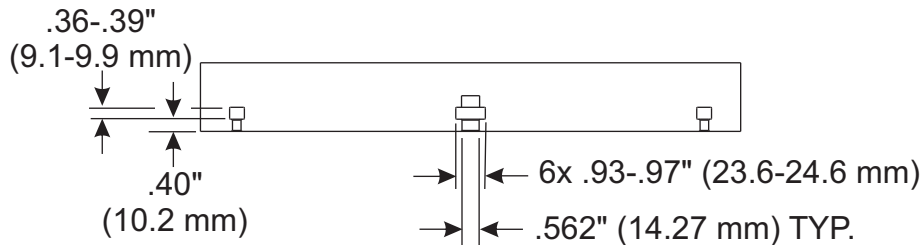

Front and Rear Tie-Down Slots

For mounting instructions, see Rotary Operator's Manual.

Go to www.haascnc.com for further rotary specifications.

