

HRT160SP Machine Layout Drawing

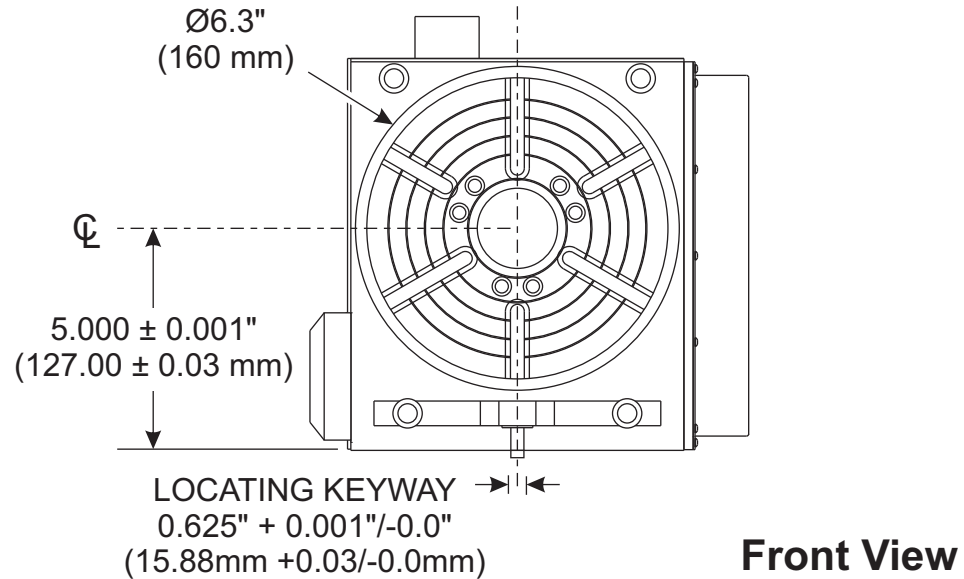

HRT160SP Machine Layout Drawing

HRT160SP Platter Dimensions

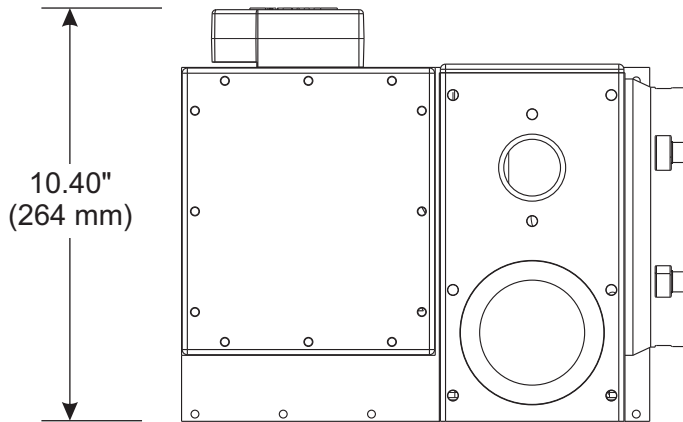
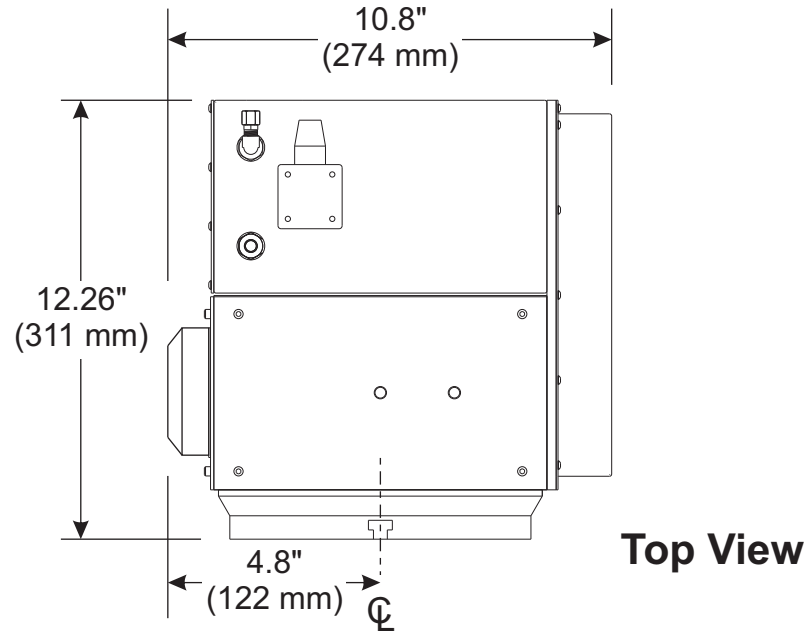
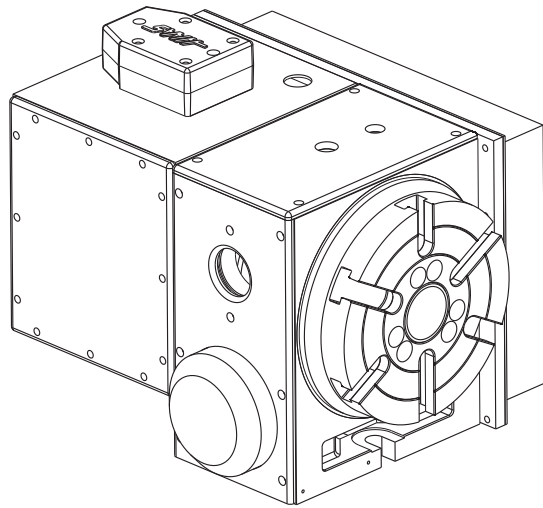
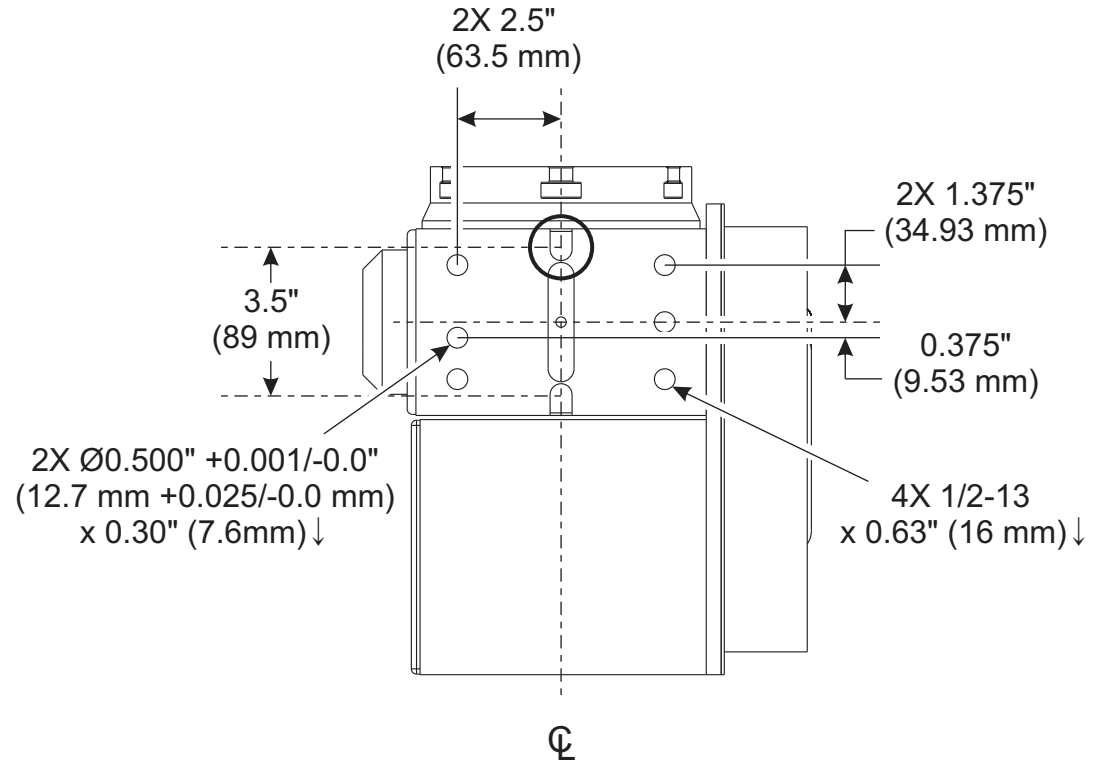
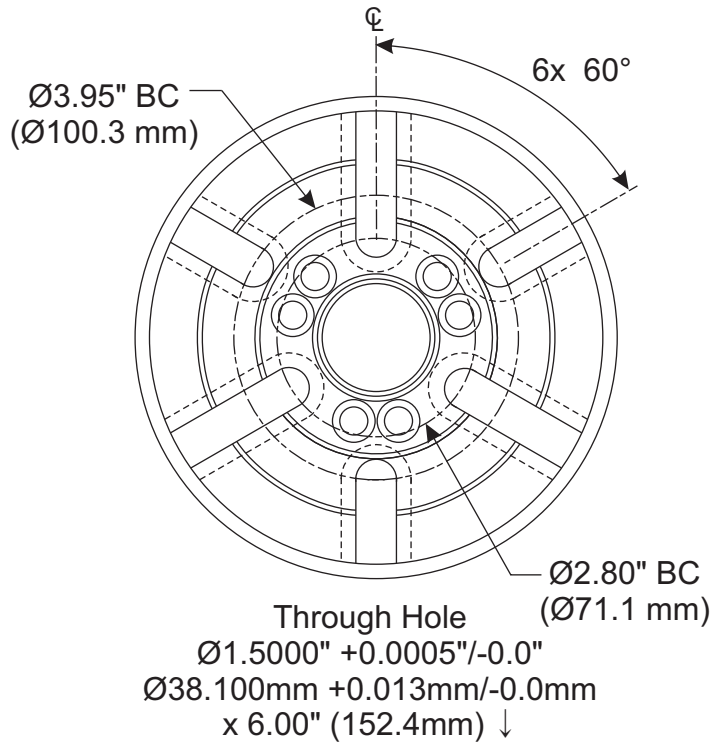

Bottom View

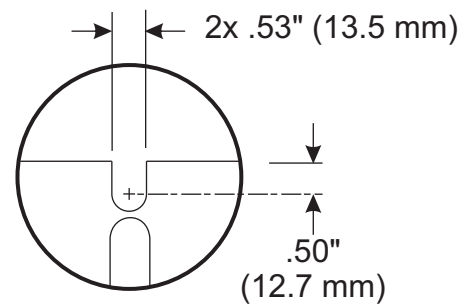
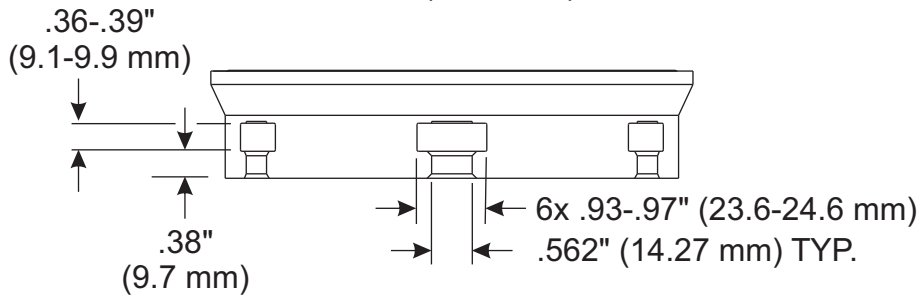

Front and Rear Tie-Down Slots

For mounting instructions, see Rotary Operator's Manual.

Go to www.haascnc.com for further rotary specifications.

