

HRC210 Machine Layout Drawing

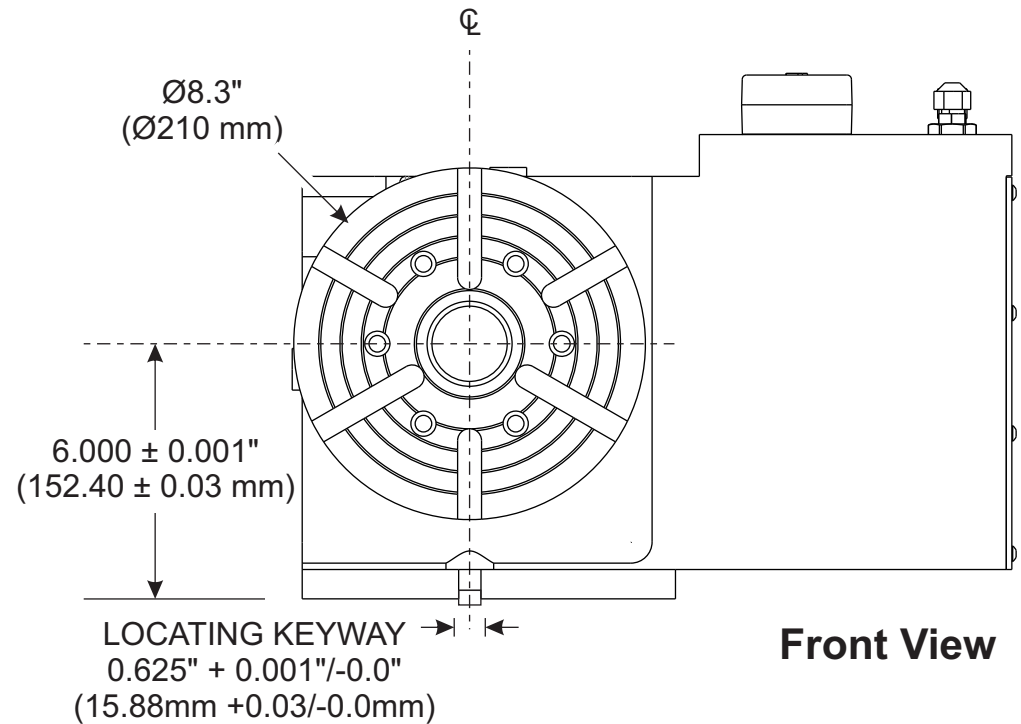

HRC210 Machine Layout Drawing

HRC210 Platter Dimensions

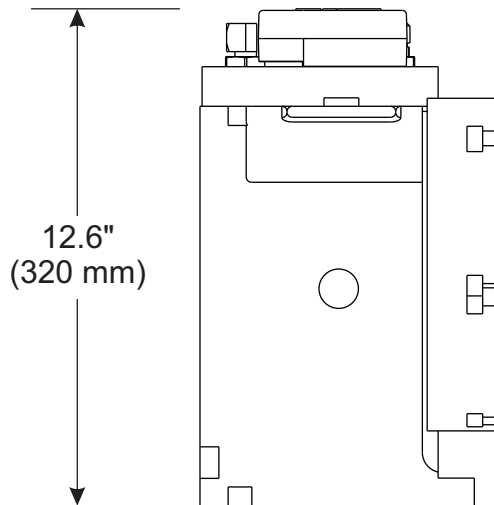
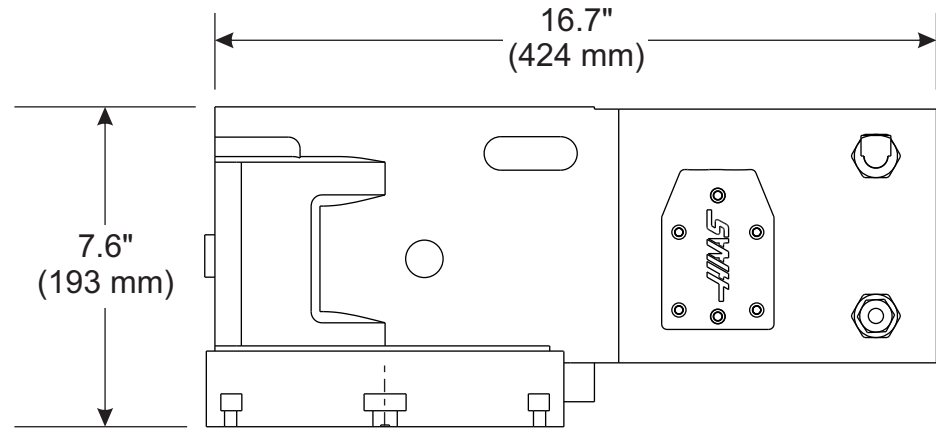
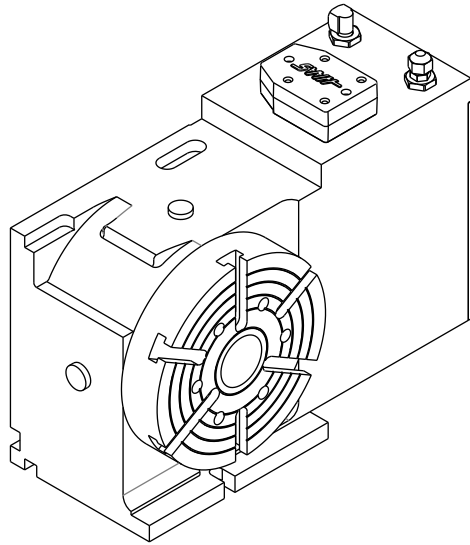
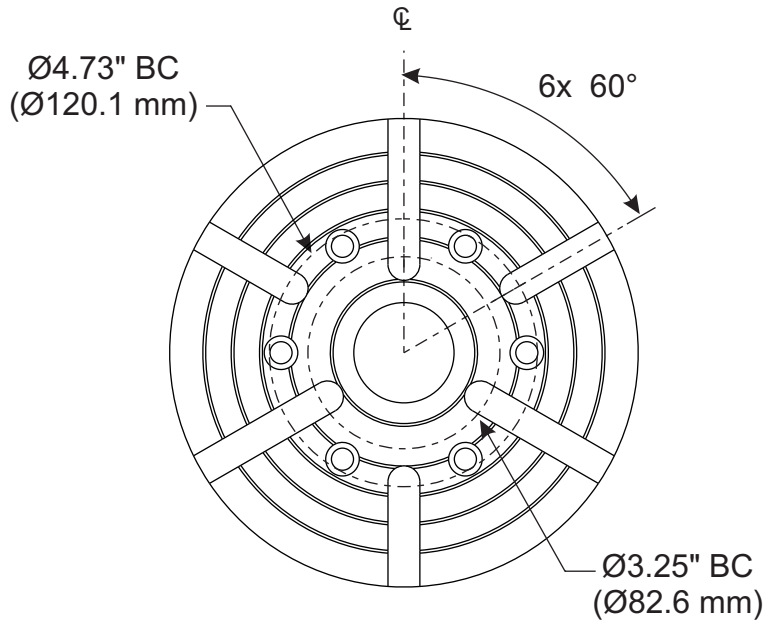

Through Hole
 $\varnothing 2.0000'' +0.0005''/-0.0''$
 $\varnothing 50.800\text{mm} +0.013\text{mm}/-0.0\text{mm}$

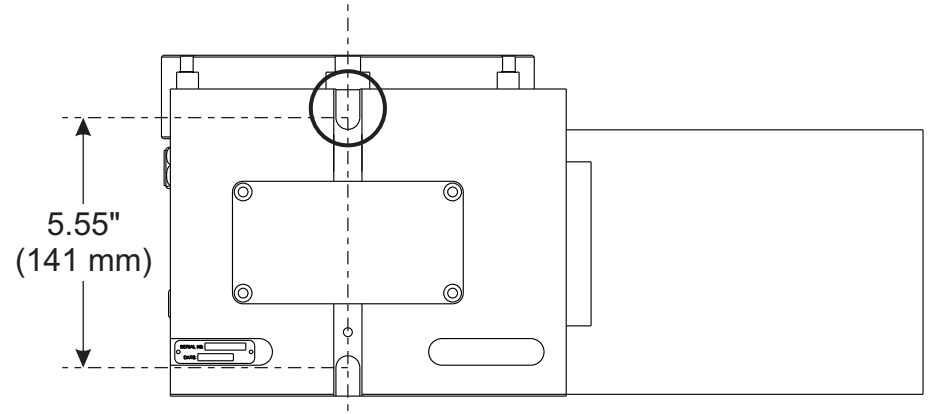

Bottom View

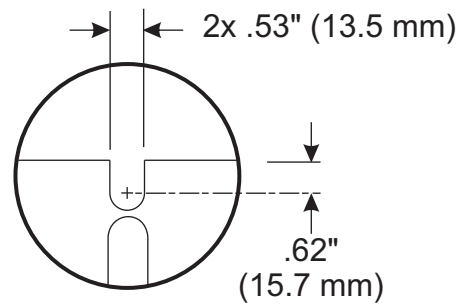
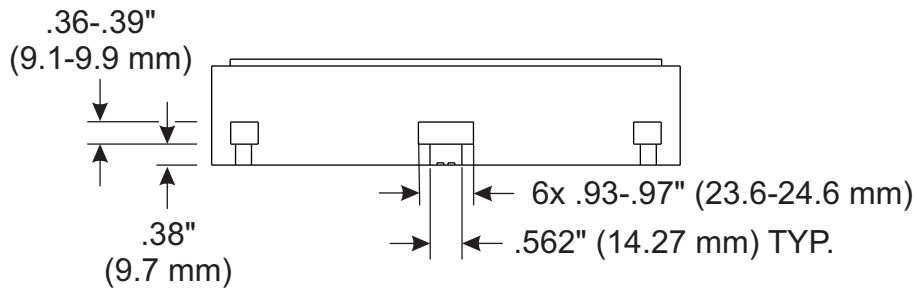

Front and Rear Tie-Down Slots

For mounting instructions, see Rotary Operator's Manual.

Go to www.haascnc.com for further rotary specifications.

