

# HA2TS Machine Layout Drawing

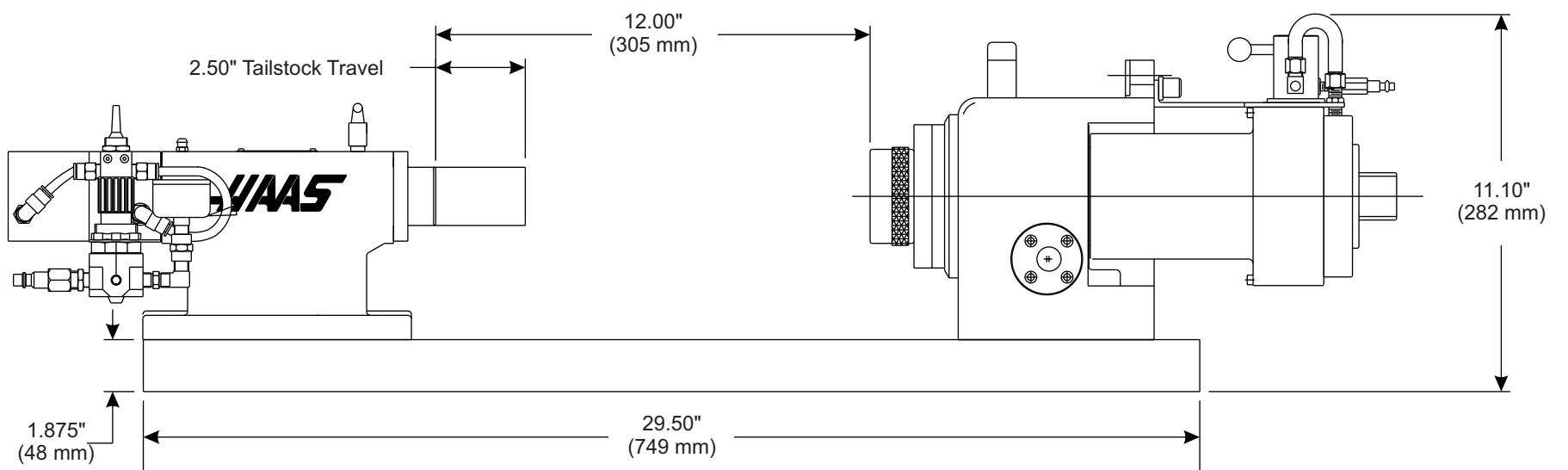
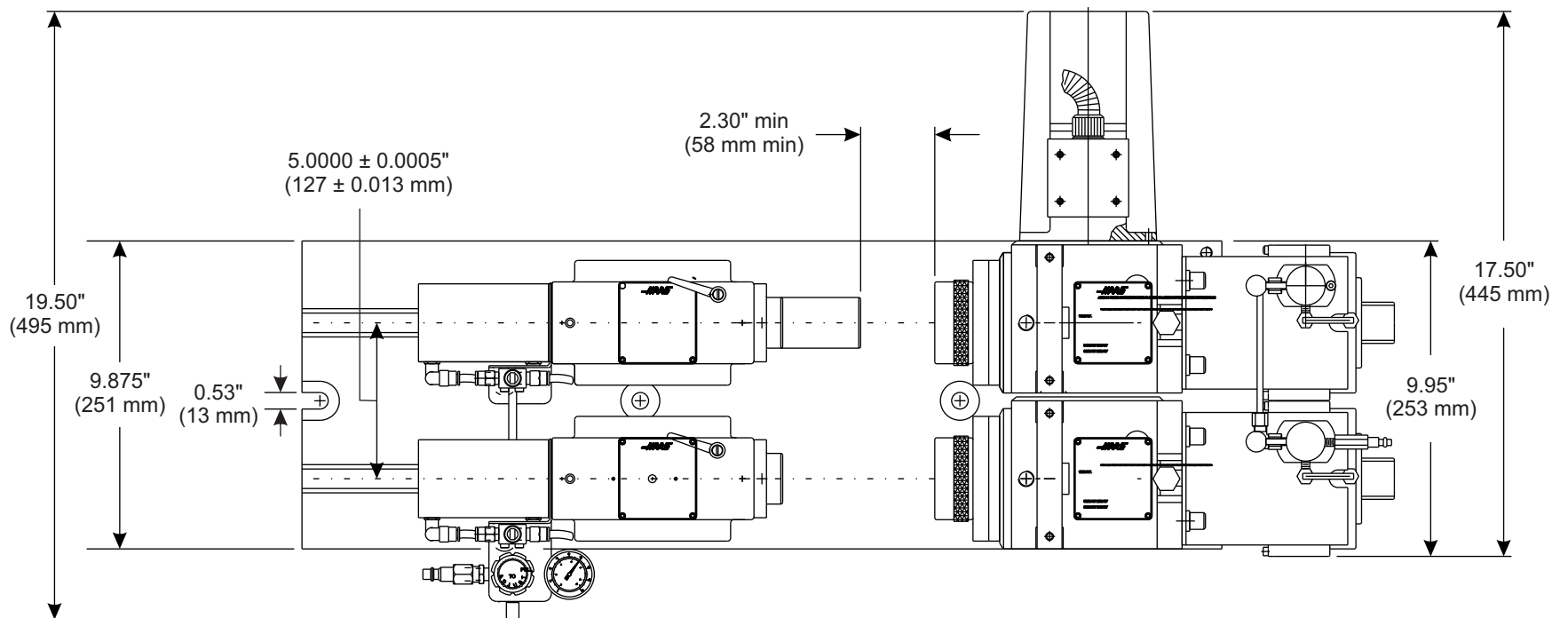

Go to [www.haascnc.com](http://www.haascnc.com)  
for further rotary specifications.

MLD-HA2TS Rev A  
Page 1 of 1  
Sep, 2014