

GR-510 Anchor Pattern

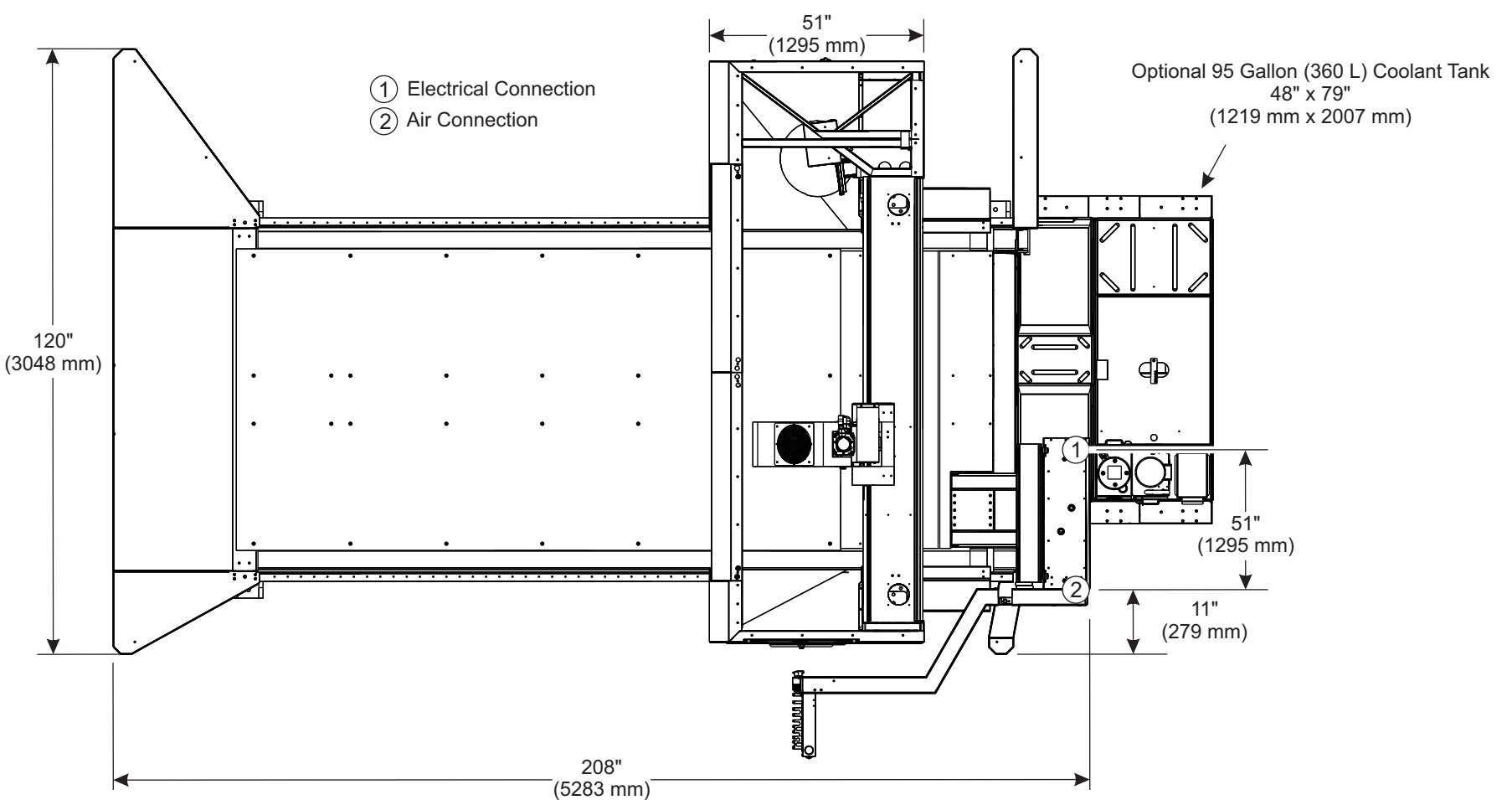

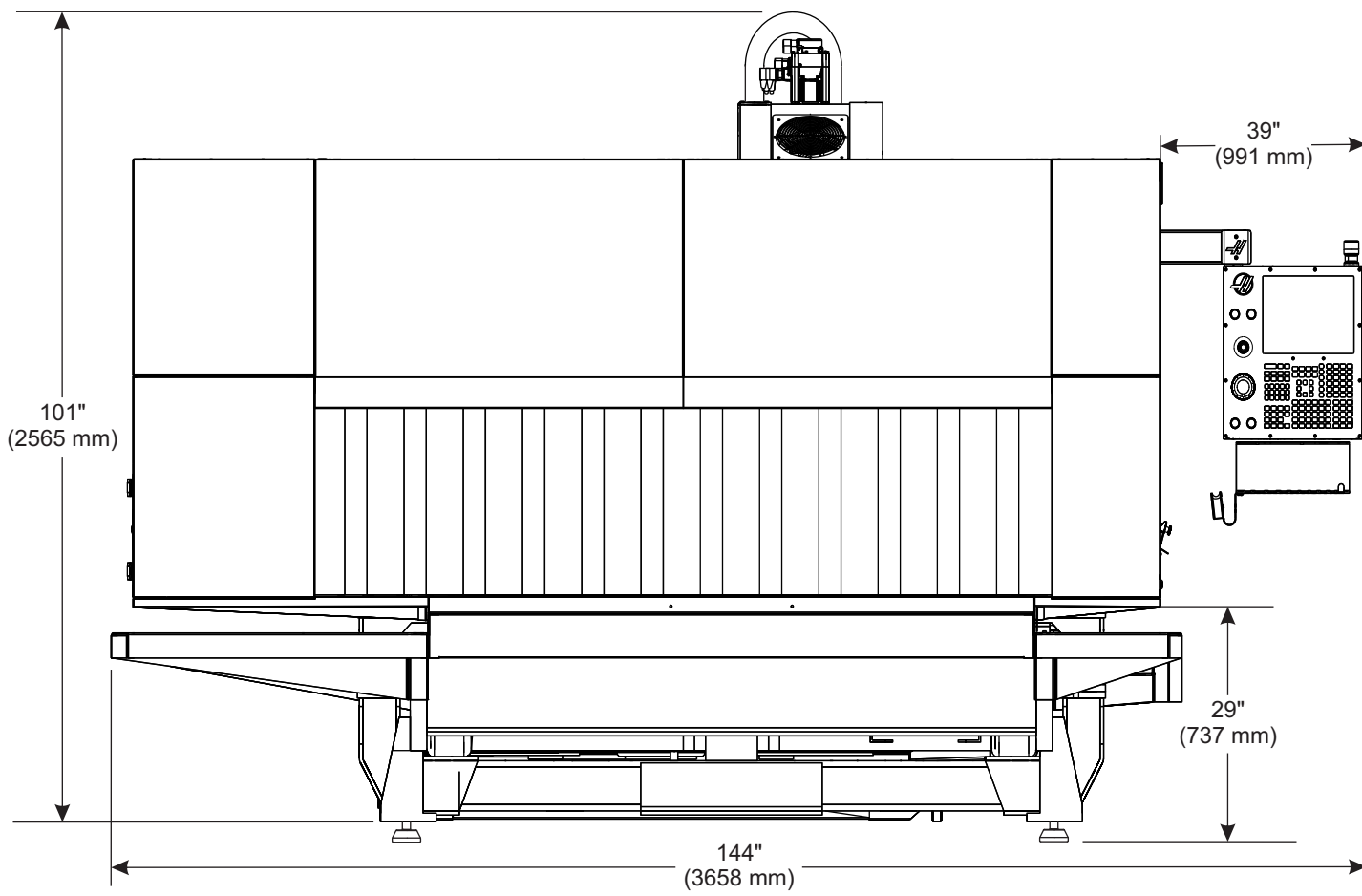
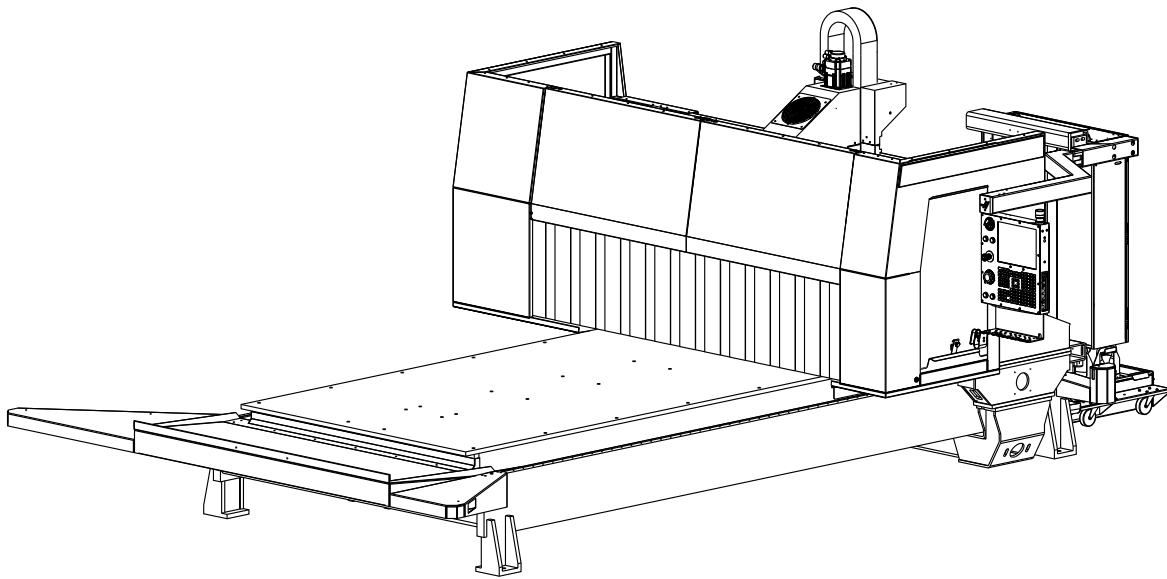
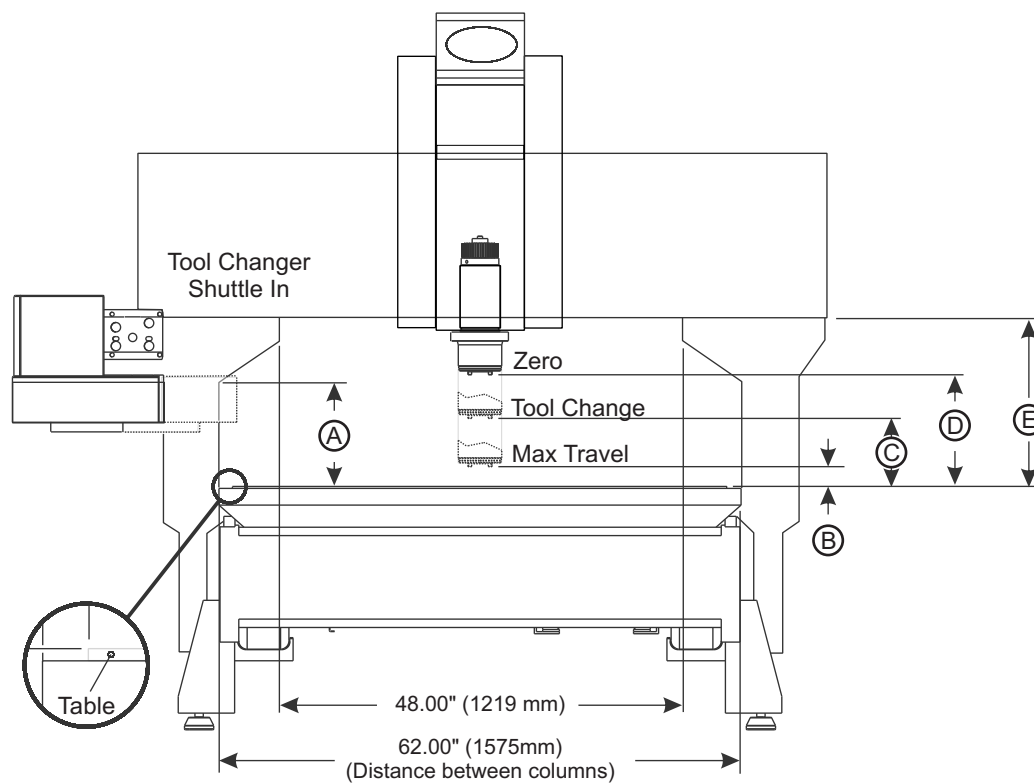
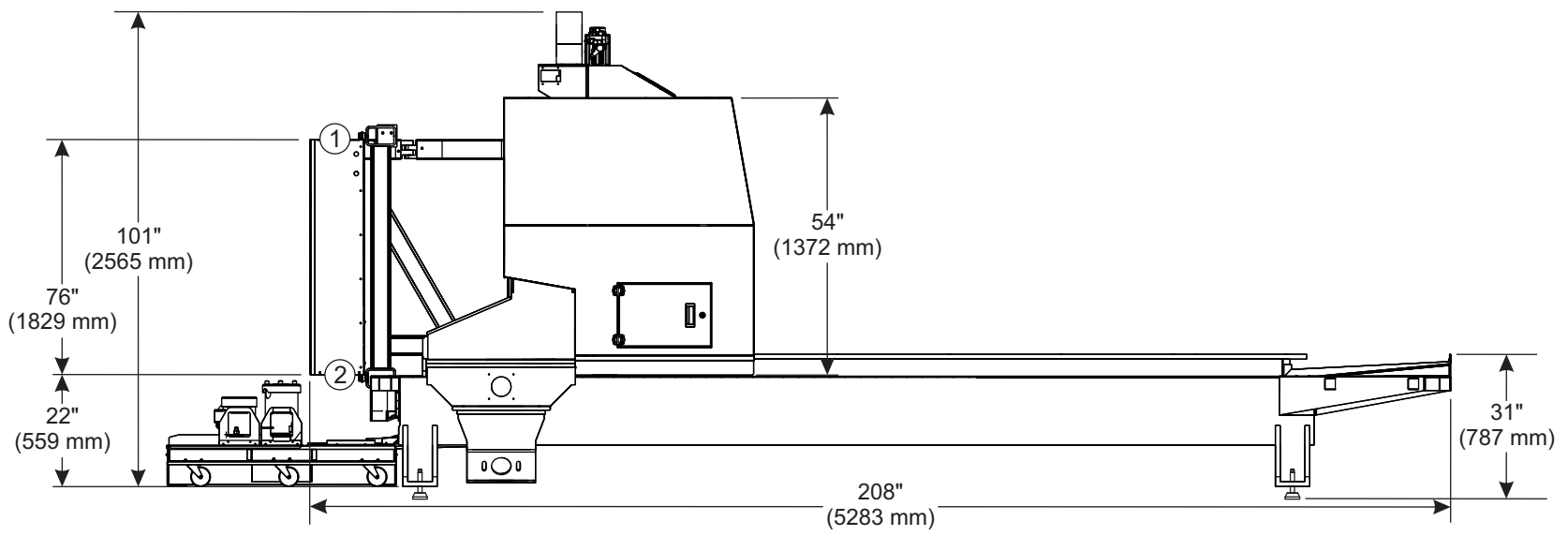
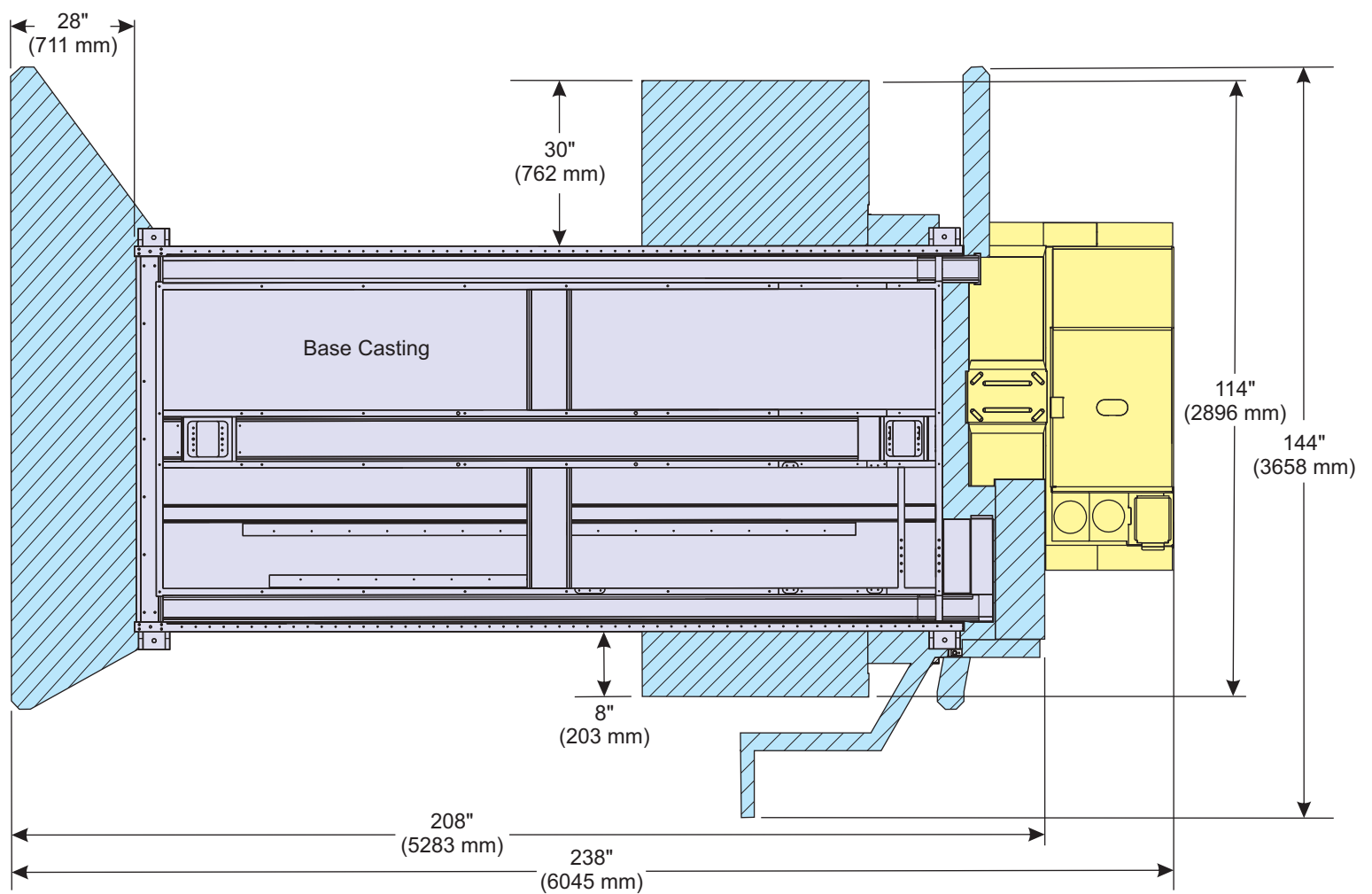

GR-510 Work Space

	Standard	6" Extended Z-Axis Clearance	24" Extended Z-Axis Travel
Ⓐ	13.00" (330 mm)	19.00" (483 mm)	27.50" (699 mm)
Ⓑ	2.50" (64 mm)	8.50" (216 mm)	4.00" (102 mm)
Ⓒ	8.25" (210 mm)	14.25" (362 mm)	23.50" (597 mm)
Ⓓ	13.50" (343 mm)	19.50" (495 mm)	28.00" (711 mm)
Ⓔ	20.25" (514 mm)	26.25" (667 mm)	34.75" (883 mm)

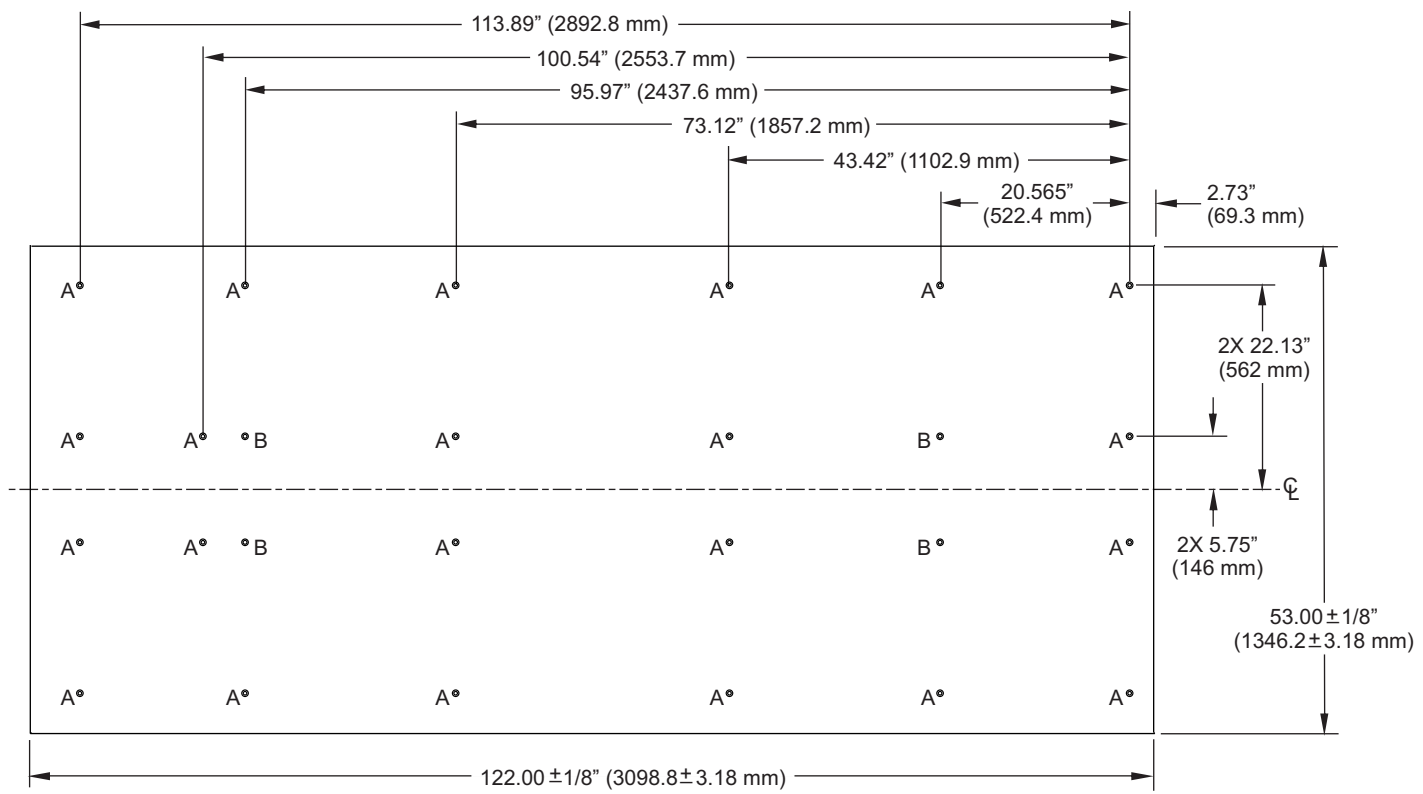

DESCRIPTION		QTY.
A	.391" (9.93 mm) Thru x C'Sink .709" (18 mm) x .49" (12.4 mm) Deep	22
B	1/2-13 UNC-2B Thru x C'Sink .709" (18 mm) x .49" (12.4 mm) Deep	4

GR-510 Aluminum Table Dimensions (Standard)

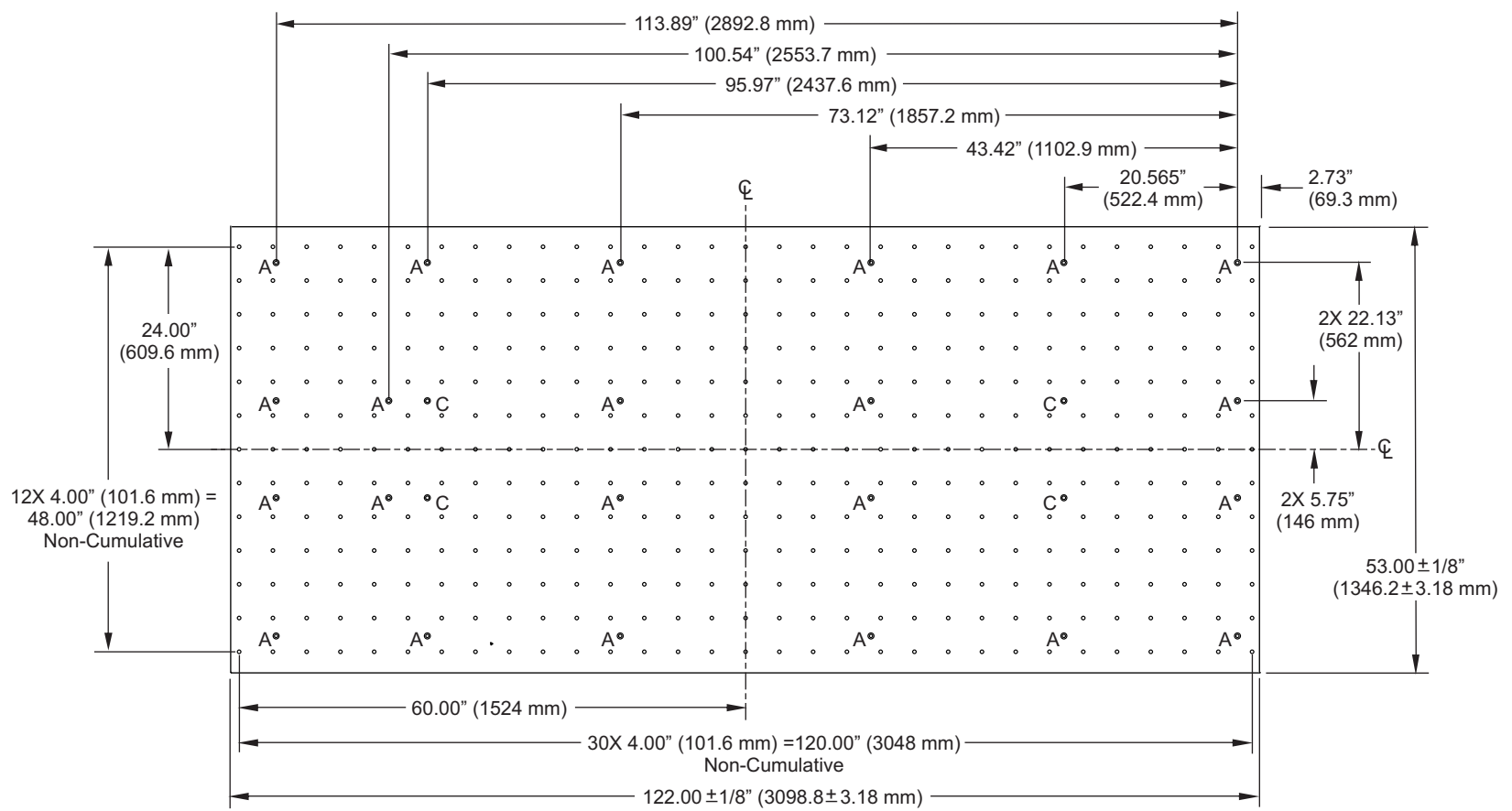

DESCRIPTION		QTY.
A	.391" (9.93 mm) Thru x C'Sink .709" (18 mm) x .49" (12.4 mm) Deep	22
C	1/2-13 UNC-2B Thru x C'Sink .709" (18 mm) x .49" (12.4 mm) Deep	4
*D	1/2-13 UNC-2B x .70 (17.8 mm) Do not drill thru	403

*All unmarked holes are "D" holes.

GR-510 Steel Table Dimensions (Optional)