

All dimensions based on stackup of sheetmetal, subject to variation of 1/2" (13 mm)
**Add 4" (101.6mm) for EC4 (Extended Clearance Option)

*Due to continual product improvements, machine dimensions are subject to change without notice.

Air & Power

Back View

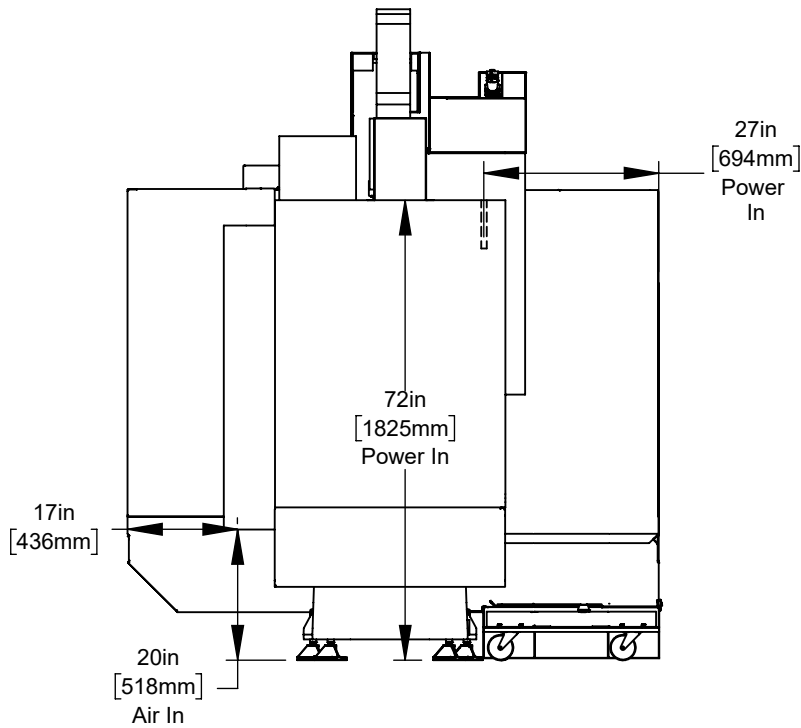

TopView

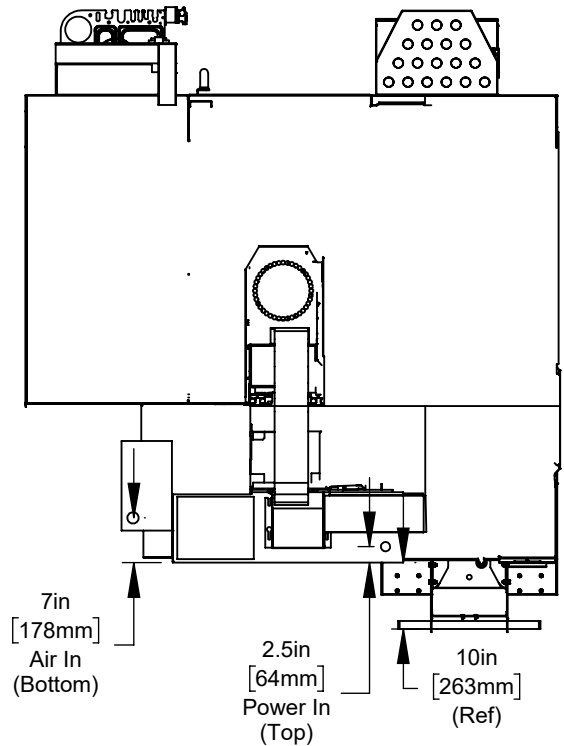

All dimensions based on stackup of sheetmetal, subject to variation of 1/2" (13 mm)
**Add 4" (101.6mm) for EC4 (Extended Clearance Option)

Anchor Pattern

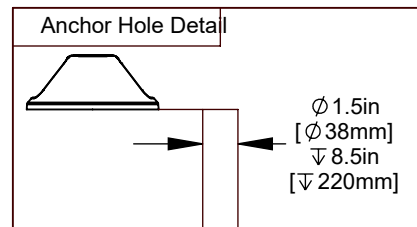
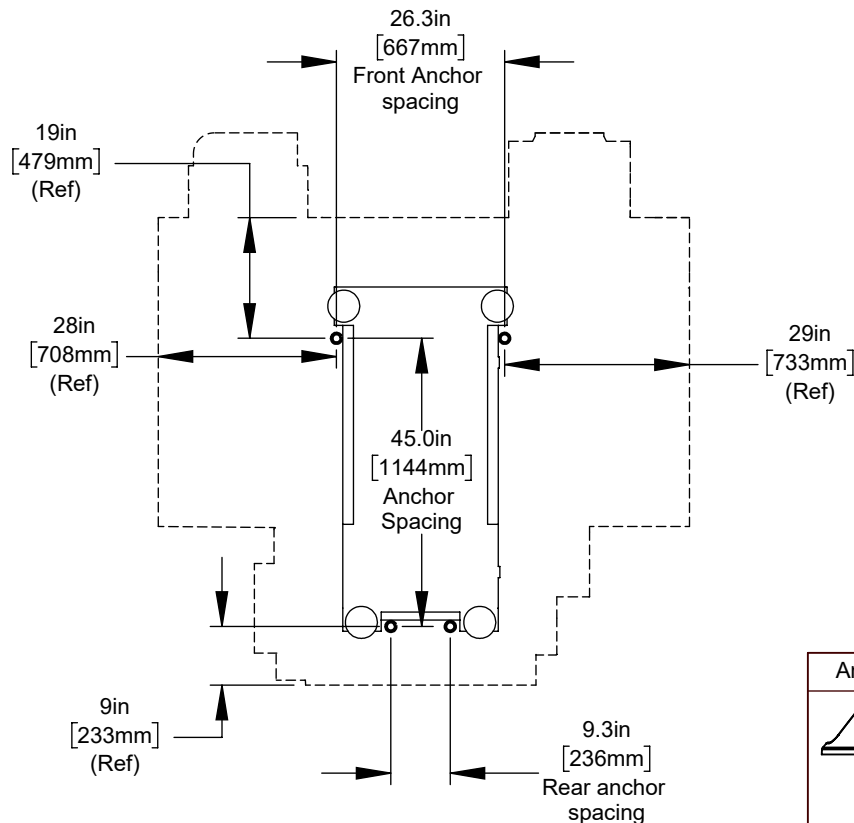

For use with Anchor Kit # 30-4535
*Applies to DT/DM machines built from July 2018 and newer

*Due to continual product improvements, machine dimensions are subject to change without notice.

Height Breakdown**

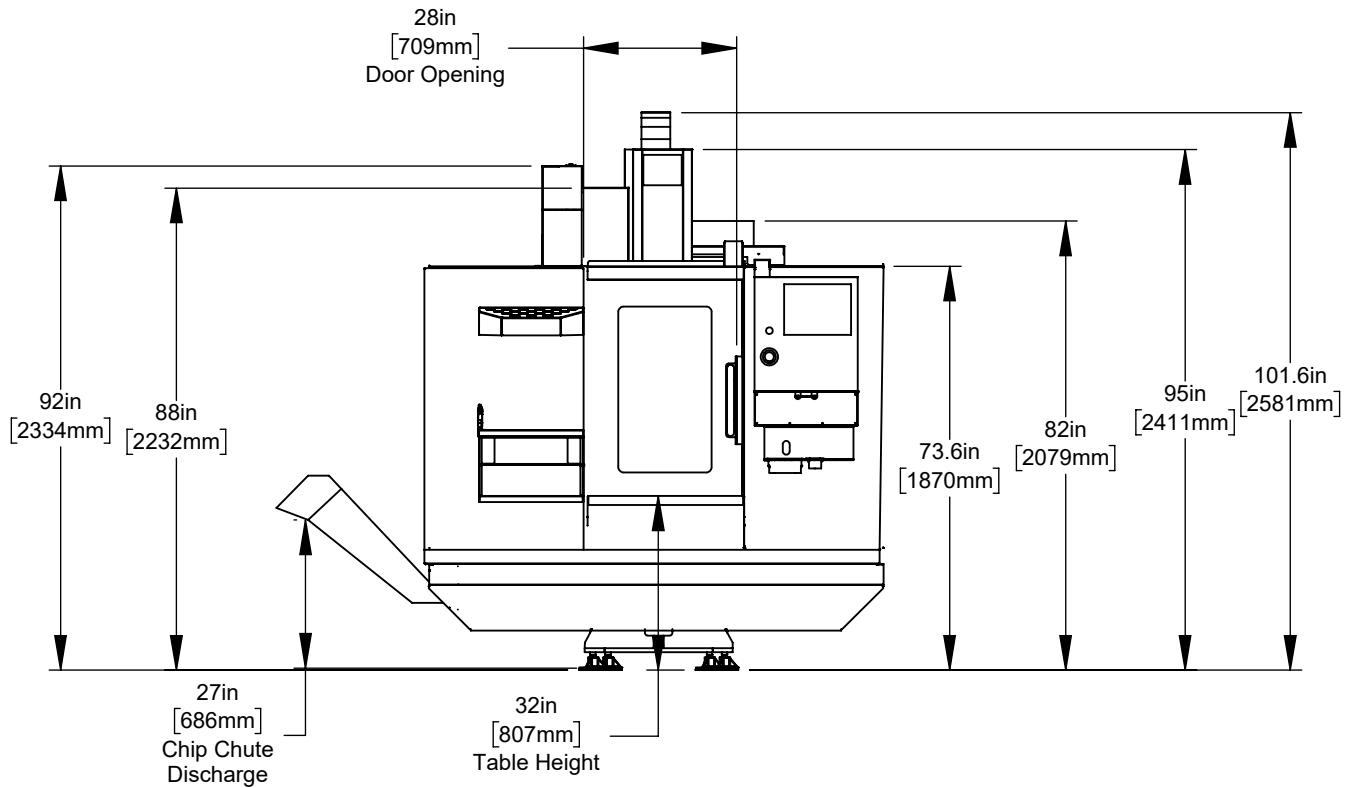

All dimensions based on stackup of sheetmetal, subject to variation of 1/2" (13 mm)
**Add 4" (101.6mm) for EC4 (Extended Clearance Option)

Width Breakdown

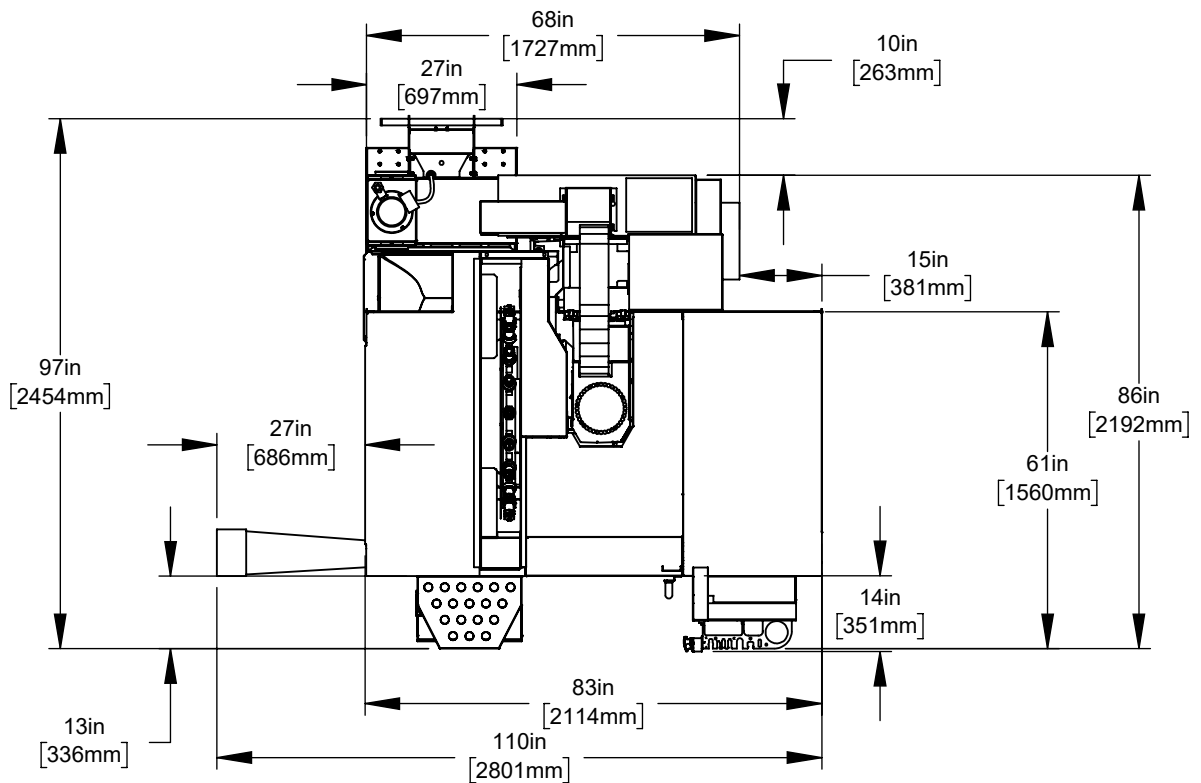

All dimensions based on stackup of sheetmetal, subject to variation of 1/2" (13 mm)

*Due to continual product improvements, machine dimensions are subject to change without notice.

X&Y-Axis Clearance

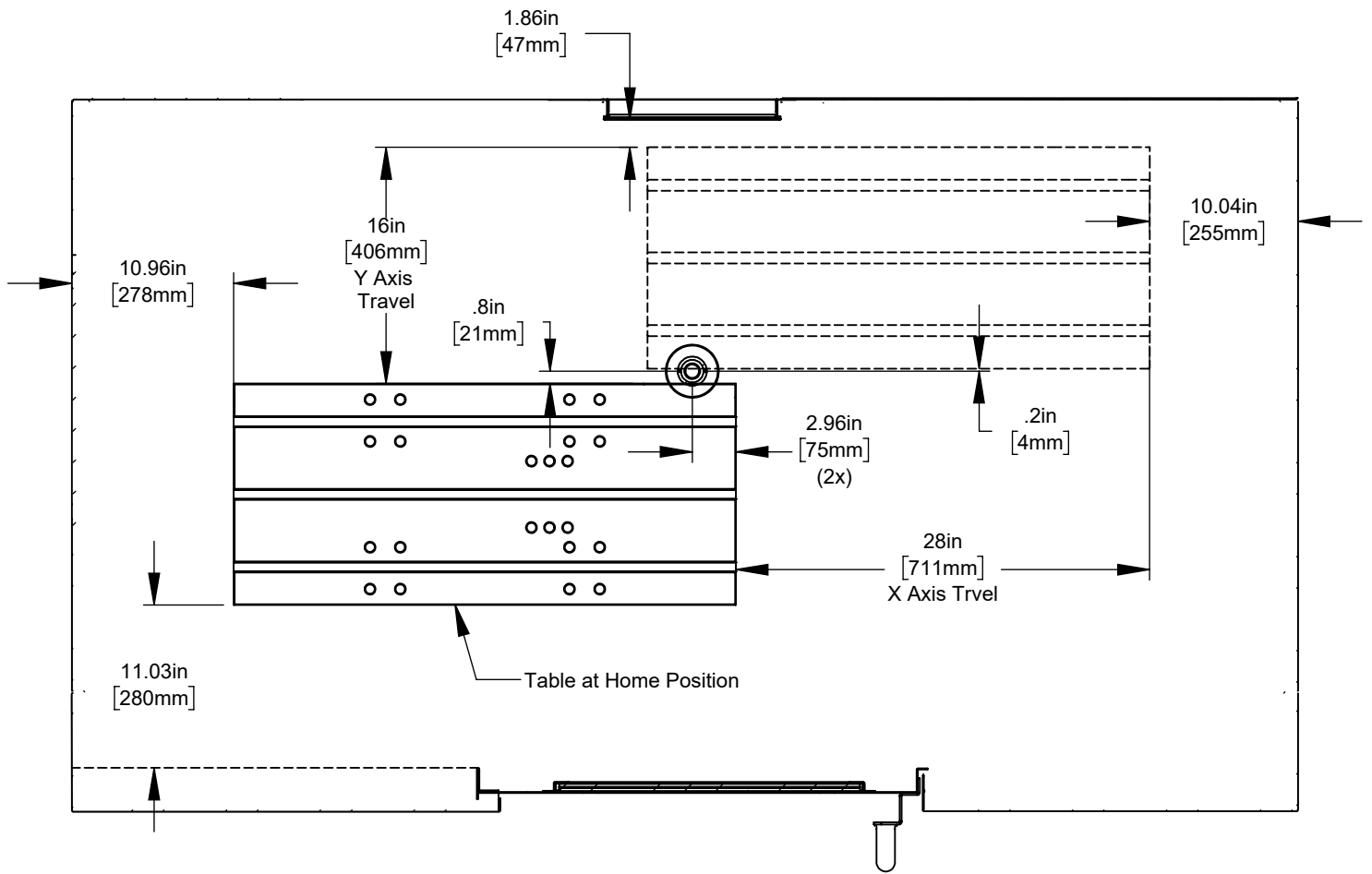

Z-Axis Clearance**

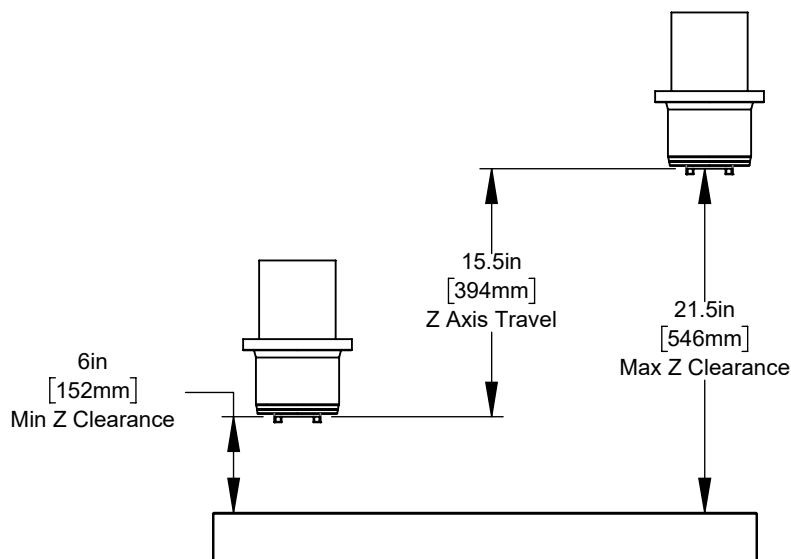

**Add 4" (101.6mm) for EC4 (Extended Clearance Option)

Table

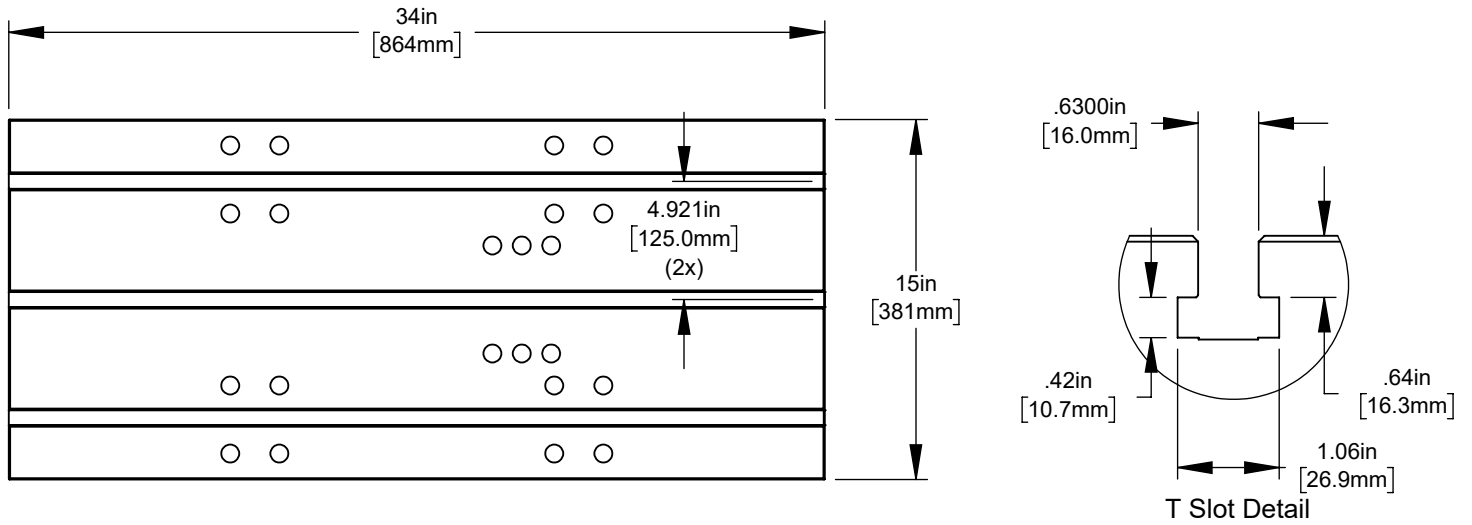

Tool Changer

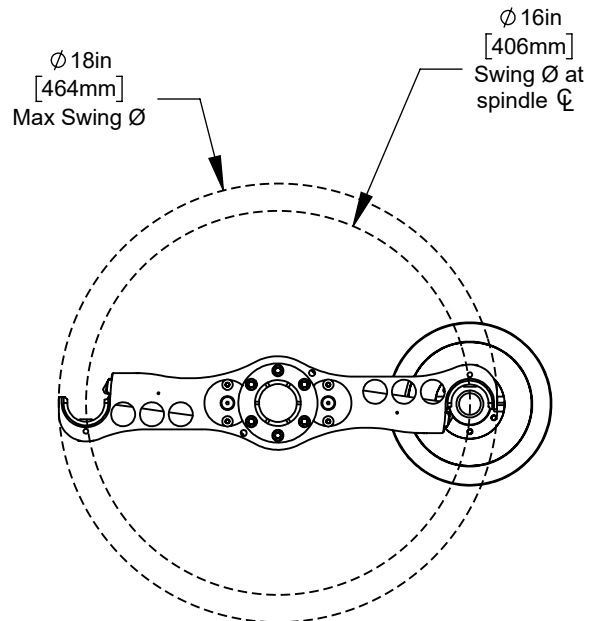
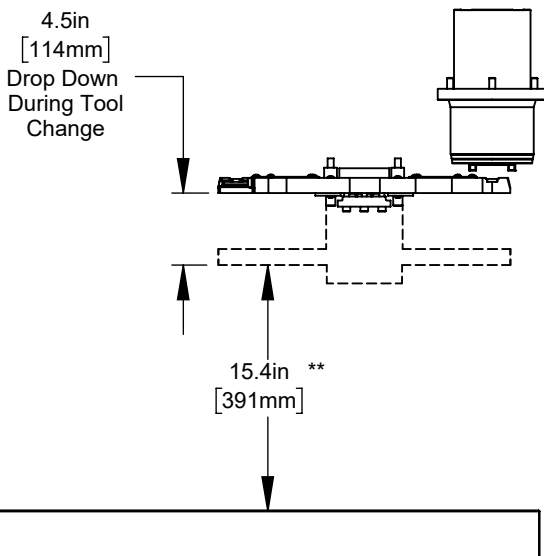

**Add 4" (101.6mm) for EC4 (Extended Clearance Option)